

WIRING DEVICES

# CATALOGUE



THE **GLOBAL SPECIALIST**  
IN ELECTRICAL AND DIGITAL BUILDING INFRASTRUCTURES

## Door entry systems



**P. 12** NEW  
Sfera modular  
entrance panels  
selection chart



**P. 14** NEW  
Sfera ROBUR  
vandal resistant  
entrance panels  
selection chart



**P. 23**  
Video internal  
units and  
handsets

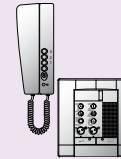

**P. 24**  
Audio internal  
units and  
handsets

## Building automation systems

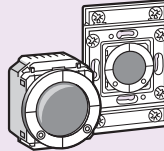

**P. 44**  
Radio/Zigbee®  
technology Arteor™  
lighting/blind control  
and automation  
mechanisms

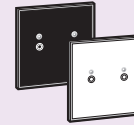

**P. 46**  
Radio/Zigbee®  
technology Arteor™  
touch plates

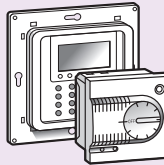

**P. 58**  
BUS/SCS  
technology  
Arteor™  
temperature  
control

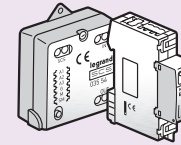

**P. 59** NEW  
BUS/SCS  
technology  
Arteor™ energy  
management

## Lighting management systems



**P. 78**  
Standalone  
sensors  
selection chart

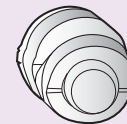

**P. 80**  
Standalone  
sensors -  
1 output



**P. 90** NEW  
BUS/SCS system  
room and DIN  
controllers  
selection charts

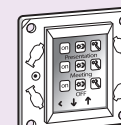

**P. 93** NEW  
BUS/SCS system  
touch screen  
control and  
DIN equipment

## Wiring accessories

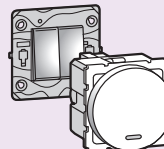

**P. 104**  
Arteor™ wiring  
accessories

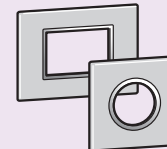

**P. 134**  
Arteor™ plates

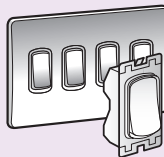

**P. 190**  
Synergy®  
grid system -  
modules and  
front plates



**P. 196**  
Clipper  
large rocker  
switches

## Domestic circuit protection



**P. 212**  
Insulated and metal  
consumer units  
surface mounting  
selection charts



**P. 213**  
Protection  
devices MCBs  
and RCBOs  
selection chart

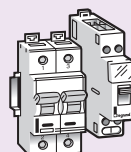

**P. 216**  
Isolating switches,  
contactor and  
modular bell  
transformers

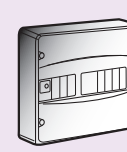

**P. 217**  
Irish  
consumer units

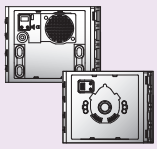

**P. 16** NEW  
Digital function modules for Sfera modular entrance panels



**P. 18**  
Sfera monobloc entrance panels selection chart

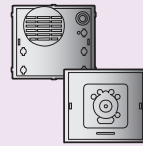

**P. 20**  
Digital function modules for Sfera monobloc entrance panels



**P. 23**  
Multimedia internal units

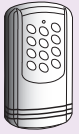

**P. 30**  
Access control

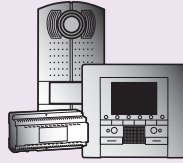

**P. 32**  
Video kits

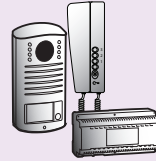

**P. 32**  
Audio kits

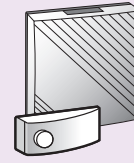

**P. 39**  
Chimes and bell push

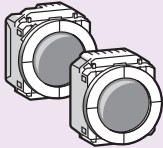

**P. 46**  
Radio/Zigbee<sup>®</sup> technology Arteor<sup>™</sup> other functions

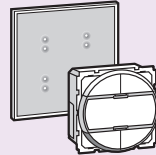

**P. 52**  
BUS/SCS technology Arteor<sup>™</sup> lighting control and automation mechanisms

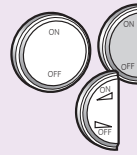

**P. 53**  
BUS/SCS technology Arteor<sup>™</sup> key covers

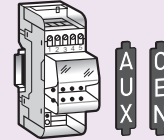

**P. 54**  
BUS/SCS technology Arteor<sup>™</sup> actuators, BUS power supplies accessories

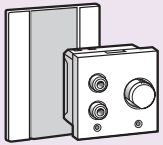

**P. 61**  
BUS/SCS technology Arteor<sup>™</sup> sound distribution

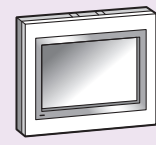

**P. 64** NEW  
BUS/SCS technology Arteor<sup>™</sup> home management system



**P. 67**  
BUS/SCS technology Arteor<sup>™</sup> video door entry system kits

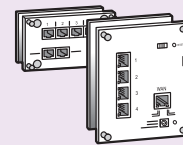

**P. 68**  
Home networks Arteor<sup>™</sup> and Synergy<sup>®</sup> structured wiring

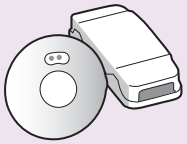

**P. 82**  
Standalone sensors - 2 outputs



**P. 86** NEW  
BUS/SCS and BUS/KNX system sensors selection chart

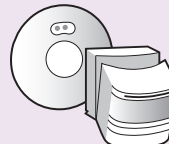

**P. 87** NEW  
BUS/SCS and BUS/KNX system sensors

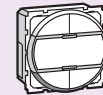

**P. 88**  
BUS/SCS and BUS/KNX system controls



**P. 94** NEW  
BUS/KNX system room and DIN controllers selection charts

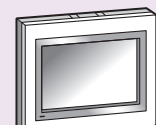

**P. 97** NEW  
BUS/KNX system touch screen control and interface



**P. 98**  
Radio/Zigbee<sup>®</sup> control units, room controllers and sensors



**P. 100** NEW  
Active building management



**P. 159**  
Synergy<sup>®</sup> White and Modern wiring accessories

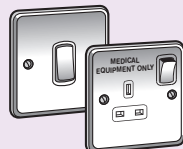

**P. 170**  
Synergy<sup>®</sup> Traditional and MEIGaN wiring accessories

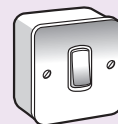

**P. 183**  
Synergy<sup>®</sup> Metalclad wiring accessories

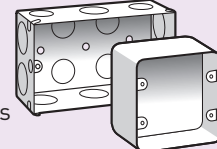

**P. 187**  
Flush and surface mounting back boxes

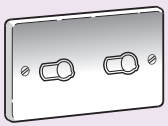

**P. 198** NEW  
Electrak<sup>®</sup> wiring accessories

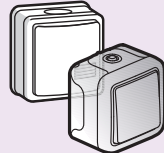

**P. 200**  
IP 66 and IP 55 weatherproof wiring accessories

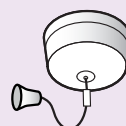

**P. 204**  
Ceiling switches and safety lampholders

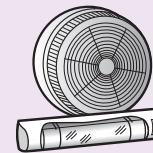

**P. 206**  
Bathroom and utility weatherproof bulkhead lighting

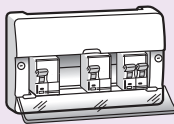

**P. 214**  
Insulated consumer units surface mounting

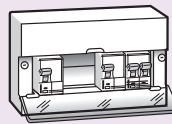

**P. 215**  
Metal consumer units surface mounting

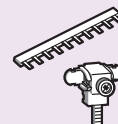

**P. 215**  
Insulated and metal accessories

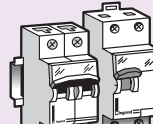

**P. 216**  
MCBs, RCDs and RCBOs

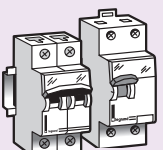

**P. 217**  
MCBs, RCDs and RCBOs for Irish consumer units

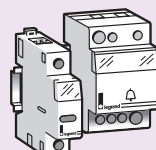

**P. 217**  
Voltage surge protector and modular bell transformers for Irish consumer units

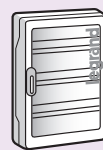

**P. 222** NEW  
Plexo<sup>3</sup> weatherproof (IP 65) enclosures for DIN rail equipment

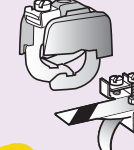

**P. 225**  
Tenby<sup>®</sup> earth clamps

# GLOBAL STRENGTH



# BUILT ON LOCAL KNOWLEDGE



Legrand is the global specialist in electrical and digital building infrastructures. Innovation is the driving force behind its development. With an increasing investment in research and development (circa 5% of sales) and more than 4,000 active patents, the Legrand Group is focused on maintaining a high rate of new product launches that present innovative solutions to the market.

## LEGRAND IN THE UK - POWERED BY SPECIALISTS

In the UK, Legrand has developed a customer focused structure which harnesses the power of its market leading specialist brands, including Bticino, Electrak and Zucchini, to deliver innovative, integrated solutions for every phase of construction.



# SUSTAINABLE DEVELOPMENT



From design through to manufacturing, the Legrand Group selects materials and processes that respect people and the environment.

- Efficient and environmentally aware product design
- Product functions that help to avoid energy waste
- Management of manufacturing and logistics sites
- Integration of environmental concerns and ISO 14001 procedures at the Group's global sites\*



## TIME SWITCHES

Simple programming can help to ensure power is only used when needed.

**(See p. 26)**



## ENERGY MANAGEMENT

A system displaying energy consumption can lead to savings of as much as 15%.

**(See p. 59)**



## LIGHTING MANAGEMENT

Lighting controls can provide energy savings of 30% to 55%.

**(See p. 76 to 101)**



## SCENARIO CONTROL AND DIMMING

Up to 58% savings on a compact fluorescent bulb with lighting dimmed to 25%.

**(See p. 115 to 116)**

\* 84% of sites are ISO 14001:2004 accredited including all UK sites.

# moving with the times



Through its continual investment in research and development, Legrand is dedicated to providing innovative products and systems that meet the demands of today and the challenges of tomorrow...



Legrand's product portfolio is constantly evolving in line with market trends and end user demands.



# alphabetical list

## A

Access control	
audio door entry kits	32
door bells, bell pushes and transformers	39
two wire door entry systems (Bticino)	12 to 31
video door entry kits - black and white	32
video door entry kits - colour	32
American standard socket outlet (Arteor)	131
Architrave switches (Synergy grid system)	194 to 195
Arteor wiring accessories	104 to 147
ancillary mechanisms	132
automatic switches	118
back boxes	133, 134, 136
blanking plates	110, 132
cable outlets	110
cooker control unit	109
curtain control	120
data sockets	126 to 127, 128
detectors (gas and water)	130
dimmers	115
double pole switches	109
electric roller blind control	120
electronic switches	114
fuse carrier units	130
fused connection unit	110
heating control	120
home networks	68 to 73
hotel equipment	121 to 123
introduction to Arteor wiring accessories	104 to 107
IP 44 plate	133
lighting control	119
lighting environment controller	116
mechanical switches	108, 111 to 112
plates – square and round	134 to 147
push buttons	113
RCBO	130
RJ 11 and RJ 45 sockets	128
sockets	
attenuator sockets	129
audio and video sockets	126 to 127
British standard socket outlets	131
International socket outlets	131
loudspeaker sockets	129
socket outlets	110
telephone sockets	128
television sockets	128
USB sockets	129
support frames	133, 134, 136
thermostats	120
technical information	
lighting environment controller	116
loads selection chart	117
USB chargers	125
triple pole switches	108
USB chargers	124
USB sockets	129
ventilation control	120
visual indication	119
wiring splitter	128
Audio door entry kits (Bticino)	32

## B

Back boxes	
architrave – flush mounting	167, 187
architrave – surface mounting	167
flush mounting boxes (Bticino)	12, 14
for grid system	194 to 195
for media plates	165, 174, 180
flush mounting – steel	167, 187
surface mounting boxes (Bticino)	12, 14
surface mounting moulded	167, 187
Bathroom lighting	
shaver lights	206
technical information – zoning	206
Bells	
bell pushes	39
bells with cover	39
transformers	39
Blanking plates	
Arteor	110, 132
Synergy metalclad	185
Synergy modern	175
Synergy traditional	181
Synergy white	166
Bticino door entry systems	
access control system	
additional equipment	30
break glass unit for emergency exit	31
code lock keypad kit (IP 67)	30
locks and accessories	31
modular proximity kit (Sfera)	30
stand alone proximity reader (IP 53)	30
audio handsets	24
audio internal units	24
composition tables for modular entrance panels	
selection charts	
colour video – Sfera	27
colour video – Sfera ROBUR	28
audio – Sfera	29
digital function modules	
for Sfera modular entrance panels	16-17
for Sfera monobloc entrance panels	20

door entry kits	
audio	32
black and white video	32
colour video	32
electronic push button panels	
with motorised camera – Axolute	22
entrance panels	12 to 21
flush mounting boxes	12, 14
handsets	23 to 24
internal units	23 to 24
introduction to door entry systems	10
IP system interface	26
monobloc entrance panels – vandal resistant	
push button panels	21
multifunctional internal units	
10" multimedia touch screen (Arteor)	23
multimedia display screens	23
surround plates	23
Sfera modular entrance panels	
selection chart	12-13
Sfera monobloc entrance panels	
selection chart	18-19
Sfera monobloc entrance panels –	
vandal resistant selection chart	21
Sfera ROBUR modular entrance panels –	
vandal resistant selection chart	14-15
surface mounting boxes	12, 14
switchboard	24
system components	25
technical information	
digital function modules	35-36
entrance panels	33-34
handsets	37
internal units	36-37
push button panels	34
time switches	38
time switches – analogue	
EconoRex MT	26
MaxiRex	26
MicroRex D	26
vandal resistant push button panels –	
Linea 2000 metal	22
video handsets	23
video internal units	23
Building automation systems	42-73
BUS/SCS technology Arteor	50-67
home networks	68-73
Radio/Zigbee technology Arteor	42-49
Bulkhead lighting – utility weatherproof	207
BUS/SCS technology	50-67
accessories	55
accessories for video door entry system	66
actuators	54
automation control mechanisms	52
BUS cables	62
contact interfaces	54
DIN controllers for dimming	54
door entry system	65
energy management	59
home management system	64
introduction to BUS/SCS technology	50-51
key covers	53
lighting control mechanisms	52
power supplies	54, 58, 62, 65
scenario controllers	52
SCS cables	55, 58
sound distribution	61-62
technical information	
lighting control and automation	56-57
sound distribution	63
temperature control	60
video and audio door entry systems	67
temperature control	58
touch screens	52, 58, 61, 64
video door entry system kits	67

## C

Cable outlets	
Arteor	110
Synergy metalclad	184
Synergy modern	173
Synergy traditional	179
Synergy white	164
Ceiling accessories	
safety lampholders	205
pendant sets	205
Ceiling switches	204
Chimes	
electromechanical chimes	39
Clipper large rocker switches	196 to 197
architrave back boxes	197
flush mounting back boxes	197
introduction to Clipper	196
large rocker switches	197
Colour video door entry kit (Bticino)	32
Cooker control units	
Arteor	109
Synergy modern	173
Synergy traditional	179
Synergy white	164
Consumer units	210 to 221
accessories for insulated and	
metal surface mounting units	215
insulated dual RCD split load	214
insulated high integrity dual RCD split load	214

insulated surface mounting units	214
introduction to consumer units	210 to 211
Irish consumer units	217
metal insulated dual RCD split load	215
metal surface mounting units	215
protection and control devices	216
selection charts	
insulated consumer units	212
protection devices – MCBs and RCBOs	213
metal consumer units	212
technical information	
insulated consumer units	218 to 219
metal consumer units	219 to 220
voltage surge protectors	221
Contactour	216
Curtain control (Arteor)	120

## D

Data sockets	
Arteor	126 to 127, 128
Synergy metalclad	185
Synergy modern	174
Synergy traditional	180
Synergy white	165
Data modules (home networks)	70
Detectors (Arteor) gas and water	30
Digital video door entry kits	32
Dimmer units	
Arteor	115
Synergy modern	170
Synergy traditional	176
Synergy white	160
Door bells, bells pushes and chimes	39
Door entry kits	
audio	32
black and white video	32
colour video	32
Door entry systems (Bticino)	10 to 38
Double pole socket outlets	
Arteor	110
Synergy metalclad	183
Synergy modern	171
Synergy traditional	177
Synergy white	161
Double pole switches	
Arteor	109
Synergy metalclad	184
Synergy modern	173
Synergy traditional	179
Synergy white	164

## E

Earth clamps – Tenby Rapid Clamp Ultra	225
EconoRex MT time switch	26
Electrak wiring accessories	198 to 199
EPOS packs	199
introduction to Electrak wiring accessories	198
plugs and accessories	199
unswitched twin socket outlets	199
UPS packs	199
Enclosures – Plexo <sup>3</sup> weatherproof	222 to 223
Euro-US standard socket outlet	131

## F

Fan switches	
Synergy modern	170
Synergy traditional	176
Synergy white	159
French standard socket outlet	131
Fused connection units	
Arteor	110
Synergy metalclad	184
Synergy modern	172
Synergy traditional	178
Synergy white	163

## G

German standard socket outlet	131
Grid system (Synergy)	190 to 195

## H

Home networks	68-73
accessories	71
audio modules	70
data modules	70
enclosures	70
introduction to home networks	68-69
power supplies	71
speakers	71
technical information – installation principle	
for distributed audio systems	72-73
telephone modules	70
video modules	70
volume control	71
Hotel equipment	121 to 123



## I

International standard socket outlets .....	131
IP door entry systems .....	26
IP table .....	232

## K

Key operated switches	
Arteor .....	119
Synergy white .....	159

## L

Lampholders .....	205
Large rocker switches (Clipper).....	196 to 197
Lighting and accessories	
bathroom .....	206
ceiling switches .....	204
energy-saving pendant set .....	205
safety lampholders .....	205
safety pendant sets .....	205
shaver light .....	206
bulkhead lighting – utility weatherproof.....	207
Lighting environment controller (Arteor) .....	116
Lighting management .....	76 to 101
building management .....	100 to 101
active building management .....	100
technical information .....	101
BUS/KNX system .....	94 to 97
accessories .....	97
DIN controllers .....	96
interface modules .....	97
room controllers .....	96
selection charts .....	
DIN controllers .....	95
room controllers .....	94
technical information .....	
installation supervision .....	97
touch screen control .....	97
BUS/SCS and BUS/KNX system sensors .....	86 to 89
ceiling sensors .....	87
selection chart .....	86
select your system .....	89
system controls .....	88
wall sensors .....	87
BUS/SCS system .....	90 to 93
accessories .....	93
DIN controllers .....	92
DIN equipment .....	93
room controllers .....	92
selection charts .....	
DIN controllers .....	91
room controllers .....	90
software .....	93
touch screen control .....	93
introduction to lighting management .....	76 to 77
Radio/Zigbee .....	98 to 99
control units .....	98
room controllers .....	98
sensors .....	99
technical information .....	
sensors and remote control devices .....	99
remote control dimmers .....	84
standalone sensors .....	78 to 85
1 output for areas benefitting from natural light .	81
1 output for areas used infrequently .....	80
2 outputs for areas benefitting from natural light	81
2 outputs for areas used infrequently .....	82
remote control dimmers .....	84
selection charts .....	78-79
technical information .....	84-85
Loud speaker sockets (Arteor).....	129

## M

MaxiRex time switches .....	26
MEIGaN sockets (Synergy) .....	182
MicroRex D time switches .....	26
Multi-standard socket outlet .....	131

## P

Pendant sets	
energy-saving pendant set .....	205
safety pendant sets .....	205
Plexo <sup>3</sup> weatherproof enclosures.....	222 to 223
accessories .....	222
enclosures IP 65 - IK 09 .....	222
technical information .....	223
Plexo weatherproof wiring accessories.....	
introduction to Plexo IP 55 and IP 66 .....	200
Plexo bulkhead lighting .....	207
Plexo modular mechanisms IP 55 .....	202 to 203
accessories .....	203
emergency stop .....	202
flush mounting frame .....	203
key operated switches .....	202
light sensitive switches .....	203
pilot light .....	203
socket outlet .....	203
surface mounting boxes .....	203
time lag switch .....	202
Plexo weatherproof IP 55 .....	202
push buttons .....	202
socket outlets .....	202
switches .....	202
Plexo weatherproof IP 66 wiring accessories.....	201

Arteor adaptors .....	201
fused spur unit .....	201
M20 cable gland .....	201
British standard 13 A socket .....	201
socket outlets .....	201
switches .....	201

## R

Radio/Zigbee technology .....	42-49
introduction to Radio/Zigbee technology .....	42-43
lighting controllers/receivers (dimmers) .....	44
lighting controllers/receivers (switches) .....	44
lighting transmitters .....	45
other functions .....	46-48
roller blind controllers/receivers (switches) .....	44
roller blind transmitters .....	45
scenario controllers .....	45
technical information .....	
switches and dimmers maximum loads .....	49
touch plates .....	48-49
touch plates (British standard) .....	46
weatherproof switches .....	47
Rapid Clamp Ultra (Tenby) .....	225
RCD sockets	
Synergy metalclad .....	183
Synergy modern .....	171
Synergy traditional .....	177
Synergy white .....	162
RJ 11 sockets .....	128
RJ 45 category 5e and 6 .....	128

## S

Shaver lights .....	206
Shaver sockets	
Arteor .....	109, 122
Synergy modern .....	171
Synergy traditional .....	178
Synergy white .....	163
Single pole switches .....	196 to 197
Clipper .....	196 to 197
Synergy metalclad .....	183
Synergy modern .....	170
Synergy traditional .....	176
Synergy white .....	159
Socket outlets	
Arteor (modular) .....	131
Arteor (monobloc) .....	110
Synergy MEIGaN .....	182
Synergy metalclad .....	183
Synergy modern .....	171
Synergy traditional .....	178
Synergy white .....	161 to 162
Speaker sockets (Arteor).....	129
Structured wiring .....	70
Synergy wiring accessories .....	148 to 195
accessories .....	
modern .....	175
traditional .....	181
white .....	166
back boxes .....	
architrave – flush mounting .....	167, 187
architrave – surface mounting .....	167
flush mounting – steel .....	167, 187
for grid system .....	194 to 195
for media plates .....	165, 174, 180
surface mounting moulded .....	167, 187
blanking plates .....	
metalclad .....	185
modern .....	175
traditional .....	181
white .....	166
cable outlets .....	
metalclad .....	184
modern .....	173
traditional .....	179
white .....	164
carrier plates and yokes .....	
metalclad .....	186
modern .....	175
traditional .....	181
white .....	165
control switches .....	
metalclad .....	184
modern .....	173
traditional .....	179
white .....	164
cooker control units .....	
modern .....	173
traditional .....	179
white .....	164
data sockets .....	
metalclad .....	185
modern .....	174
traditional .....	180
white .....	165
dimmers .....	
modern .....	170
traditional .....	176
white .....	160
fan switches .....	
modern .....	170
traditional .....	176
white .....	159
fused connection units .....	
metalclad .....	184
modern .....	172
traditional .....	178
white .....	163
grid systems (Synergy) .....	190 to 195
ancillary modules .....	191

dimmer modules .....	191
fuse carrier modules .....	191
selection charts .....	192 to 195
switch modules .....	191
technical information .....	
introduction to Synergy grid system.....	188 to 189
introduction to Synergy .....	
wiring accessories .....	148 to 151
media plates .....	
traditional .....	180
white .....	165
MEIGaN sockets .....	182
selection charts .....	
carrier plates .....	158
functions and finishes .....	152 to 157
standard engraving (white).....	169
shaver sockets .....	
modern .....	171
traditional .....	178
white .....	163
socket outlets .....	
MEIGaN .....	182
metalclad .....	183
modern .....	171
traditional .....	177 to 178
white .....	161 to 162
switches .....	
metalclad .....	183
modern .....	170
traditional .....	176
white .....	159
standard engraving (white) .....	169
technical information .....	
sample wiring schemes .....	168
television, telephone and data sockets .....	
metalclad .....	185
modern .....	174
traditional .....	180
white .....	165
unswitched socket outlets .....	
modern .....	171
traditional .....	177
metalclad .....	183
white .....	161

## T

Telephone modules (home networks) .....	70
Telephone sockets	
Arteor .....	128
Synergy metalclad .....	185
Synergy modern .....	174
Synergy traditional .....	180
Synergy white .....	165
Tenby Rapid Clamp Ultra – earth clamps.....	225
Thermostats (Arteor).....	120
Time switches – analogue	
EconoRex MT .....	26
MaxiRex .....	26
MicroRex D .....	26
technical information .....	38
Transformers	
bell transformers .....	39
TV, radio and satellite sockets	
Arteor .....	128
Synergy metalclad .....	185
Synergy modern .....	174
Synergy traditional .....	180
Synergy white .....	165

## U

Unswitched socket outlets	
Synergy modern .....	171
Synergy traditional .....	177
Synergy metalclad .....	183
Synergy white .....	161
US-Euro standard socket outlet .....	131
USB sockets (Arteor).....	129

## V

Video (Bticino)	
door entry kits .....	32
video handsets .....	23
video internal units.....	23
Video modules (home networks) .....	70

## Y

Yokes (Synergy grid) .....	158
----------------------------	-----

### Conditions of sale

please consult our current price list

In accordance with its policy of continuous improvement, the Company reserves the right to change specifications and designs without notice. All illustrations, descriptions, dimensions and weights in this catalogue are for guidance and cannot be held binding on the Company.

All contents and design presentation included in this publication are © Legrand Electric Limited. All rights reserved. 2012



# Door entry systems



**P. 10**  
Introduction to door entry systems

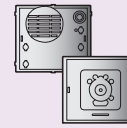

**P. 20**  
Digital function modules for Sfera monobloc entrance panels



**P. 23**  
Multimedia internal units

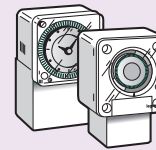

**P. 26**  
Analogue time switches – MaxiRex and EconoRex

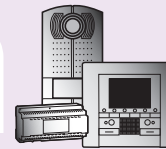

**P. 32**  
Video kits

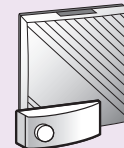

**P. 39**  
Chimes and bell push

**Bticino 2 wire door entry systems**

**Bticino door entry kits**

**Chimes and bells**

## NEW IN 2012



**Sfera**  
Modular entrance panels  
**(p. 12)**



**Sfera ROBUR**  
Vandal resistant modular entrance panels  
**(p. 14)**



**P. 12** NEW  
Sfera modular  
entrance panels  
selection chart



**P. 14** NEW  
Sfera ROBUR  
vandal resistant  
entrance panels  
selection chart

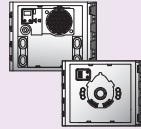

**P. 16** NEW  
Digital function  
modules for  
Sfera modular  
entrance panels



**P. 18**  
Sfera monobloc  
entrance panels  
selection chart



**P. 21**  
Vandal resistant  
scrolling entrance  
panels selection  
chart

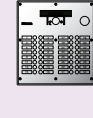

**P. 21**  
Monobloc  
vandal resistant  
push button  
entrance panels

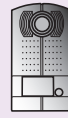

**P. 22**  
Vandal resistant  
push button  
panels



**P. 22** NEW  
Electronic push  
button panels  
with motorised  
camera



**P. 23**  
Video internal  
units and  
handsets

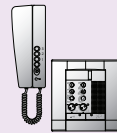

**P. 24**  
Audio internal  
units and  
handsets



**P. 24**  
Switchboard



**P. 25**  
System  
components

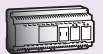

**P. 26**  
IP system  
interface



**P. 27**  
Composition  
tables

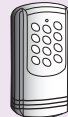

**P. 30**  
Access  
control



**P. 32**  
Audio kits

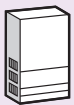

**P. 39**  
Bells and  
safety isolating  
transformer



## Digital function modules

For Sfera modular  
entrance panels  
(p. 16)

# Italian style 2 wire innovation

Bticino's NEW Sfera modular entrance panel range offers a selection of functions and finishes to suit any installation.





Sfera... stylish durability

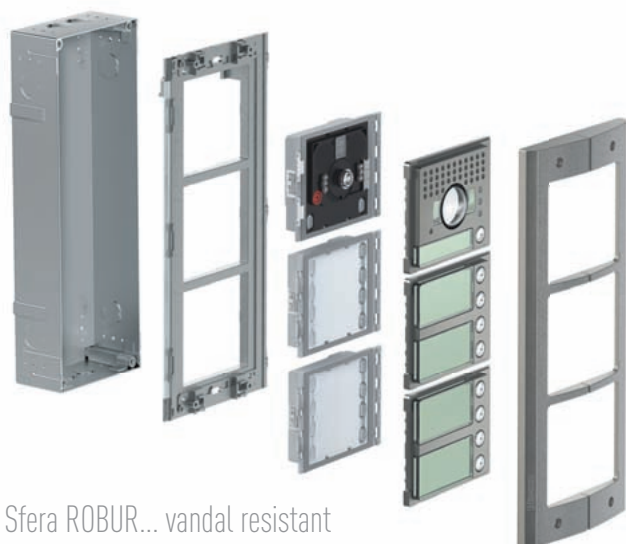

Sfera ROBUR... vandal resistant

## New Sfera... two personalities one electronic heart

Sfera's modular composition allows a range of functions to be combined with the finish of your choice.

Three stylish standard finishes are available to suit a building's design scheme along with vandal resistant panels for extra strength and security.

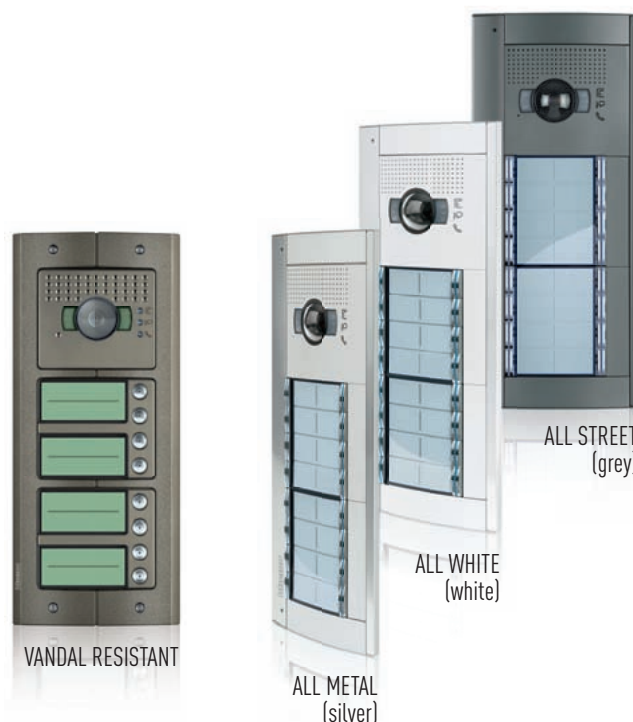

ALL STREET  
(grey)

ALL WHITE  
(white)

ALL METAL  
(silver)

VANDAL RESISTANT













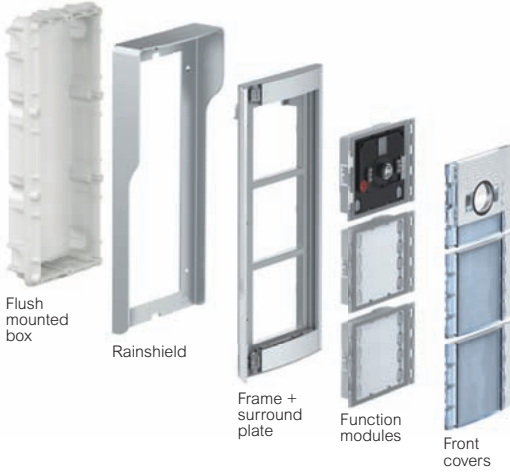







## Bticino handsets and internal units... adding contemporary style to any installation

From audio and video handsets through to multimedia touch screens integrated with building automation systems, Legrand's range of internal units cover all requirements from simple to complex systems.

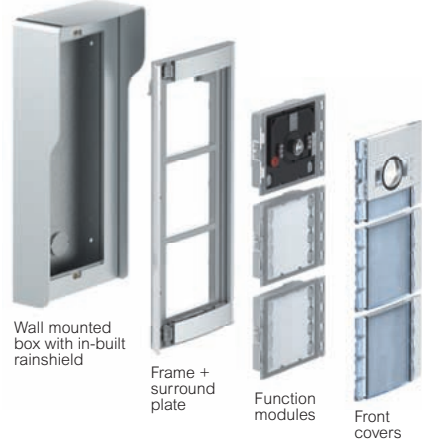

**Bticino modular entrance panels**  
Sfera

 Dimensions p. 33

FINISHES	INSTALLATION TYPE	FLUSH MOUNTING BOXES	RAINSHIELDS (OPTIONAL) <sup>1, 2</sup>	FRAMES / PLATES <sup>(2)</sup>
<p><b>CHOOSE YOUR FINISH</b> Replace the dots in the Cat. No. with either 1, 2, or 3 to select the desired finish</p> <p><b>1</b> All metal (silver)</p>  <p><b>2</b> All white (white)</p>  <p><b>3</b> All street (grey)</p> 	<p><b>FLUSH MOUNTING INSTALLATION</b></p>  <p>Flush mounted box</p> <p>Rainshield</p> <p>Frame + surround plate</p> <p>Function modules</p> <p>Front covers</p>	<p><b>3500 10</b> 1 module</p>  <p><b>3500 20</b> 2 modules</p>  <p><b>3500 30</b> 3 modules</p> 	<p><b>3505 1..</b> 1 module</p>  <p><b>3505 2..</b> 2 modules</p>  <p><b>3505 3..</b> 3 modules</p>  <p><b>3505 4..</b> 4 modules</p>  <p><b>3505 6..</b> 6 modules</p>  <p><b>3505 9..</b> 9 modules</p> 	<p><b>3502 1..</b> 1 module</p>  <p><b>3502 2..</b> 2 modules</p>  <p><b>3502 3..</b> 3 modules</p> 
	<p><b>SURFACE MOUNTING INSTALLATION</b></p>  <p>Wall mounted box with in-built rainshield</p> <p>Frame + surround plate</p> <p>Function modules</p> <p>Front covers</p>	<b>SURFACE MOUNTING BOXES<sup>(2)</sup></b>		
		<p><b>3506 1..</b> 1 module</p>  <p><b>3506 2...</b> 2 modules</p>  <p><b>3506 3..</b> 3 modules</p> 	<p><b>3506 4..</b> 4 modules</p>  <p><b>3506 6..</b> 6 modules</p>  <p><b>3506 9..</b> 9 modules</p> 	

1 : For flush mounting only











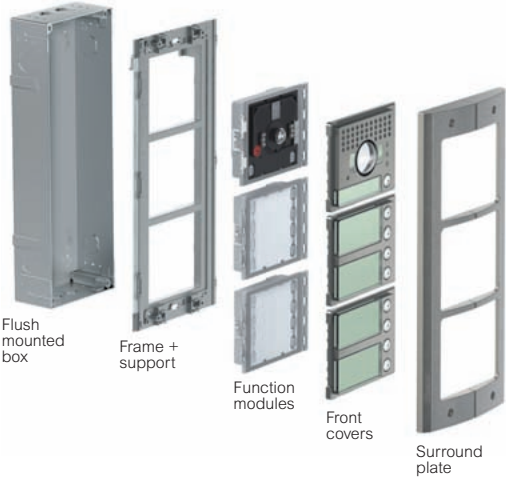





2 : To select desired finish, please see "CHOOSE YOUR FINISH", top left

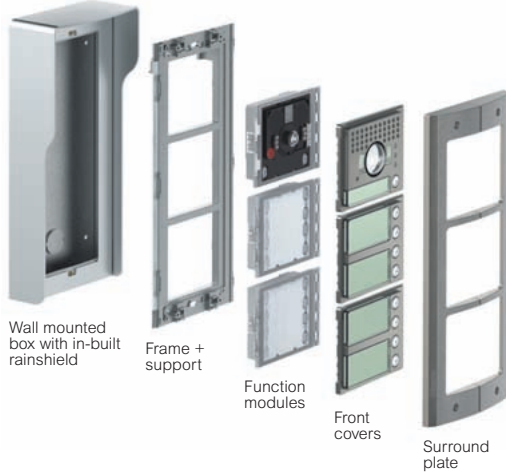

	DIGITAL FUNCTION MODULES	FRONT COVERS <sup>(2)</sup>				
Speakers	<p><b>3510 00</b> Basic speaker module</p>	<b>Audio front covers</b>				
	<p><b>3511 00</b> Speaker module</p>	<p><b>3510 0...</b> Basic speaker module</p>	<p><b>3510 1...</b> Basic speaker module 1 push button</p>	<p><b>3510 2...</b> Basic speaker module 2 push buttons</p>	<p><b>3510 4...</b> Basic speaker module 2 push buttons / double row</p>	<p><b>3510 8...</b> Basic speaker module 4 push buttons / double row</p>
Push buttons	<p><b>3520 00</b> 4 push buttons / single row</p>	<p><b>3520 3...</b> 3 push buttons</p>	<p><b>3520 4...</b> 4 push buttons</p>			
	<p><b>3521 00</b> 8 push buttons / double row</p>	<p><b>3521 6...</b> 6 push buttons / double row</p>	<p><b>3521 8...</b> 8 push buttons / double row</p>			
Cameras	<p><b>3512 00</b> Audio / video</p>	<b>Video front covers</b>				
	<p><b>3513 00</b> Audio / video with wide angle camera</p>	<p><b>3512 0...</b> Audio / video</p>	<p><b>3512 1...</b> Audio / video 1 push button</p>	<p><b>3512 2...</b> Audio / video 2 push buttons / double row</p>		
	<p><b>3524 00</b> Night / day with wide angle camera</p>	<p><b>3513 0...</b> Audio / video wide angle</p>	<p><b>3513 1...</b> Audio / video wide angle 1 push button</p>	<p><b>3513 2...</b> Audio / video wide angle 2 push buttons / double row</p>	<p><b>3540 00</b> cable for the connection of several push button modules L=620 mm</p>	
Miscellaneous	<p><b>3522 00</b> Name plate</p>	<b>Miscellaneous front covers</b>				
	<p><b>3525 00</b> Graphic display</p>	<p><b>3522 0...</b> Name plate</p>				
	<p><b>3527 00</b> Inductive loop and control speech synthesis</p>	<p><b>3525 0...</b> Graphic display</p>	<p><b>3527 0...</b> Inductive loop - speech synthesis</p>			
	<p><b>3532 00</b> Badge reader</p>	<p><b>3527 0...</b> Inductive loop - speech synthesis</p>	<p><b>3532 0...</b> Badge reader</p>	<p><b>3523 0...</b> blanking module</p>		
	<p><b>3530 00</b> Keypad</p>	<p><b>3530 0...</b> Keypad</p>				
<p><b>3533 00</b> Fingerprint</p>	<p><b>3533 0...</b> Fingerprint</p>	<div style="border: 1px solid black; padding: 5px; text-align: center;"> <p><b>CHOOSE YOUR FINISH</b> Replace the dots in the Cat. No. with either 1, 2, or 3 to select the desired finish</p> </div>				

**Bticino modular entrance panels - vandal resistant**  
Sfera ROBUR

 Dimensions p. 33

FINISHES		FLUSH MOUNTING BOXES	SUPPORT FRAMES	SURROUND PLATES
<p>Vandal resistant (ROBUR)</p> 	<p><b>FLUSH MOUNTING INSTALLATION</b></p>  <p>Flush mounted box</p> <p>Frame + support</p> <p>Function modules</p> <p>Front covers</p> <p>Surround plate</p>	<p><b>3501 10</b> 1 module</p>  <p><b>3501 20</b> 2 modules</p>  <p><b>3501 30</b> 3 modules</p> 	<p><b>3503 15</b> 1 module</p>  <p><b>3503 25</b> 2 modules</p>  <p><b>3503 35</b> 3 modules</p> 	<p><b>3504 15</b> 1 module</p>  <p><b>3504 25</b> 2 modules</p>  <p><b>3504 35</b> 3 modules</p> 
	<p><b>WALL MOUNTING INSTALLATION</b></p>  <p>Wall mounted box with in-built rainshield</p> <p>Frame + support</p> <p>Function modules</p> <p>Front covers</p> <p>Surround plate</p>	<p><b>SURFACE MOUNTING BOXES<sup>1</sup></b></p> <p><b>3506 15</b> 1 module</p>  <p><b>3506 45</b> 4 modules</p>  <p><b>3506 25</b> 2 modules</p>  <p><b>3506 65</b> 6 modules</p>  <p><b>3506 35</b> 3 modules</p>  <p><b>3506 95</b> 9 modules</p> 		

<sup>1</sup> : For flush mounting only





	DIGITAL FUNCTION MODULES	FRONT COVERS					
Speakers	<p><b>351000</b> Basic speaker module</p>	<b>Audio front covers</b>					
	<p><b>351100</b> Speaker module</p>	<p><b>351005</b> Basic speaker module</p>	<p><b>351015</b> Basic speaker module 1 push button</p>	<p><b>351025</b> Basic speaker module 2 push buttons</p>	<p><b>351045</b> Basic speaker module 2 push buttons / double row</p>	<p><b>351085</b> Basic speaker module 4 push buttons / double row</p>	
Push buttons	<p><b>352000</b> 4 push buttons / single row</p>	<p><b>352035</b> 3 push buttons</p>	<p><b>352045</b> 4 push buttons</p>				
	<p><b>352100</b> 8 push buttons / double row</p>	<p><b>352165</b> 6 push buttons / double row</p>	<p><b>352185</b> 8 push buttons / double row</p>				
Cameras	<p><b>351200</b> Audio / video</p>	<b>Video front covers</b>					
	<p><b>351300</b> Audio / video with wide angle camera</p>	<p><b>351205</b> Audio / video</p>	<p><b>351215</b> Audio / video 1 push button</p>	<p><b>351225</b> Audio / video 2 push buttons / double row</p>			
	<p><b>352400</b> Night / day with wide angle camera</p>	<p><b>351305</b> Audio / video with wide angle</p>	<p><b>351315</b> Audio / video wide angle 1 push button</p>	<p><b>351325</b> Audio / video wide angle 2 push buttons / double row</p>	<p><b>354000</b> cable for the connection of several push button modules L=620 mm</p>		
Miscellaneous	<p><b>352200</b> Name plate</p>	<b>Miscellaneous front covers</b>					
	<p><b>352500</b> Graphic display</p>	<p><b>352205</b> Name plate</p>					
	<p><b>352700</b> Inductive loop and control speech synthesis</p>	<p><b>352705</b> Inductive loop - speech synthesis</p>					<p><b>352305</b> Blanking module</p>
	<p><b>353200</b> Badge reader</p>	<p><b>353205</b> Badge reader</p>					
	<p><b>353000</b> Keypad</p>	<p><b>353005</b> Keypad</p>					
<p><b>353300</b> Fingerprint</p>	<p><b>353305</b> Fingerprint</p>						

**Bticino digital function modules**  
for Sfera modular entrance panels



3510 00



3511 00



3512 00



3513 00



3520 00



3521 00



3524 00



Selection charts **p. 12-15**

Dimensions and technical information **p. 35-36**

**Digital function modules are compatible with Sfera modular entrance panels**

Pack	Cat. Nos.	<b>Speaker modules</b>
		Fitted with loudspeaker and microphone volume adjustment Manages up to 100 push button calls when using additional double row push button modules, see 13 and 15 Require surround plate, see 12 and 14
1	3510 00	<b>Basic speaker module</b> For audio systems Device must be manually configured
1	3511 00	<b>Speaker module</b> For audio and video systems Preset for additional power supply Front LEDs display notification of operating status : • door lock release • communication active • put call through • system busy Integrated optic sensor provides backlight for night visibility Device can be configured either manually or via PC and TiSferaDesign software
		<b>Push button modules</b> Used with speaker modules, Cat. Nos. 3510 00/3511 00 and audio/video modules, Cat. Nos. 3512 00/3513 00 Connect using cable (supplied) Require surround plate, (p. 12 and 14)
1	3520 00	4 push button module / single column
1	3521 00	8 push button module / single column
		<b>Accessory for push button modules</b>
1	3540 00	Cable for connecting several push button modules

Pack	Cat. Nos.	<b>Camera modules</b>
		For colour video systems Colour camera with 1/3" sensor and white LEDs for illuminating the shooting field Mist prevention / heating resistance Fitted with loudspeaker and microphone volume adjustment Manage up to 98 push button calls using additional double row push button modules, see opposite Require surround plate, (p. 12 and 14) Preset for additional power supply Front LEDs display notification of operating status : • door lock release • communication active • put call through • system busy Integrated optic sensor provides backlight for night visibility Device can be configured either manually or via PC and TiSferaDesign software
1	3512 00	<b>Audio / video module</b> Horizontal and vertical camera position adjustment, +/- 10° in both directions
1	3513 00	<b>Wide angle audio/video module</b> For wide angle viewing Horizontal : 240 cm @ 50 cm Vertical : 115 cm @ 50 cm Does not required horizontal or vertical adjustment
1	3524 00	<b>Night / day and wide angle camera module</b> For colour video systems Fitted with 1/3" sensor with night and day function and automatic removal of the IR filter IR LED for illuminating the field of view Automatic brightness adjustment Connects to speaker module (Cat. No. 3511 00) using cable (supplied)



For module front covers  
see p. 12 to 15

**NEW**

**Bticino digital function modules**  
for Sfera modular entrance panels (continued)



3522 00

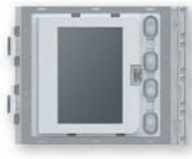

3525 00



3527 00



3530 00



3532 00



3533 00



Selection charts **p. 12-15**  
Dimensions and technical information **p. 35-36**

**Digital function modules are compatible with Sfera modular entrance panels**

Pack	Cat. Nos.	Miscellaneous modules
1	3522 00	<b>Nameplate module</b> Normally used for displaying house number or other notifications (e.g. legend for calls using digital push button panels, opening/closing times, etc.) Connect using cable (supplied) Backlight for night visibility controlled by speaker module (Cat. Nos. 3510 00/3511 00) or audio/video module (Cat. No. 3512 00) connected Requires surround plate, see p. 12 and 14
1	3525 00	<b>Graphic display module</b> Used with speaker module Cat. No. 3511 00 or with audio / video modules Cat. Nos. 3512 00/3513 00 Connect using cable (supplied) Can operate in two modes : call from address book, or digital call Stores up to 4 000 residents names Using the keypad module Cat. No. 3530 00 allows : <ul style="list-style-type: none"> <li>• direct calls to apartments by entering the corresponding number to the resident</li> <li>• digital calls by entering the numerical code</li> </ul> Can be configured either manually or via PC and TiSferaDesign software Requires surround plate, see p. 12 and 14
1	3527 00	<b>Inductive loop and control speech synthesis module</b> Used with speaker module Cat. No. 3511 00 or with audio / video modules Cat. Nos. 3512 00 /3513 00 Enables use by people wearing hearing aids (fitted with T selector) or blind people via voice message synthesis (call active, call ended, no answer, busy, door open) Connects to speaker module using cable (supplied) Can be configured either manually or via PC and TiSferaDesign software Requires surround plate, see p. 12 and 14























Pack	Cat. Nos.	Miscellaneous modules (continued)
1	3530 00	<b>Keypad module</b> For door lock release, or digital call to an apartment (with display module Cat. No. 3525 00) Fitted with relay with contacts and clamps for connecting to a local door lock release push button Numerical code can be programmed to open door lock using keypad, or using a PC, after downloading the module programming file Programming reset push button and LEDs for visual notification of access status LEDs provide backlight for night visibility Connected to other modules using cable (supplied) Device may also be used as stand alone unit, with independent power supply and operation Can be configured either manually or via PC and TiSferaDesign software Requires surround plate, see 12 and 14
1	3532 00	<b>RFID badge reader module</b> For door lock release via swiping badge Manages up to 20 000 badges Fitted with relay contacts and clamps for connection of a local door release push button Badges can be programmed from module itself, or using a PC after downloading the module programming file Programming reset push button and LEDs for visual notification of access status LEDs provide backlight for night visibility Connected to other modules using cable (supplied) Device may also be used as stand alone unit, with independent power supply and operation Can be configured either manually or via PC and TiSferaDesign software Requires surround plate, see 12 and 14
1	3533 00	<b>Fingerprint reader module</b> For door lock release Fitted with relay contacts and clamps for connecting to a local door release push button Programming reset push button and LEDs for visual notification of access status Connected to other modules using cable (supplied) Device may also be used as stand alone unit, with independent power supply and operation Can be configured either manually or via PC and TiSferaDesign software Requires surround plate, see 12 and 14



For module front covers  
see **p. 12 to 15**













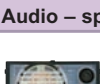

# Bticino monobloc entrance panels

Sfera

FINISHES	MONOBLOC FRONT COVERS		 Dimensions <b>p. 34</b>
<p>Stainless steel</p> 	<p><b>Video – cameras, speakers and push buttons</b></p> <div style="display: flex; justify-content: space-around; align-items: flex-start;"> <div style="text-align: center;">  <p><b>3338 64</b> Stainless steel <b>3338 65</b> Polished brass 6 push buttons</p> </div> <div style="text-align: center;">  <p><b>3338 44</b> Stainless steel <b>3338 45</b> Polished brass 4 push buttons</p> </div> <div style="text-align: center;">  <p><b>3338 34</b> Stainless steel <b>3338 35</b> Polished brass 3 push buttons</p> </div> <div style="text-align: center;"> <p>1</p>  <p><b>3338 24</b> Stainless steel <b>3338 25</b> Polished brass 2 push buttons</p> </div> <div style="text-align: center;">  <p><b>3338 14</b> Stainless steel <b>3338 15</b> Polished brass 1 push button</p> </div> </div>		
<p>Polished brass</p> 	<p><b>Audio – speaker and push button covers</b></p> <div style="display: flex; justify-content: space-around; align-items: flex-start;"> <div style="text-align: center;">  <p><b>3331 04</b> Stainless steel <b>3331 05</b> Polished brass 10 push buttons</p> </div> <div style="text-align: center;">  <p><b>3331 84</b> Stainless steel <b>3331 85</b> Polished brass 8 push buttons</p> </div> <div style="text-align: center;">  <p><b>3331 64</b> Stainless steel <b>3331 65</b> Polished brass 6 push buttons</p> </div> <div style="text-align: center;">  <p><b>3331 44</b> Stainless steel <b>3331 45</b> Polished brass 4 push buttons</p> </div> <div style="text-align: center;"> <p>1</p>  <p><b>3331 34</b> Stainless steel <b>3331 35</b> Polished brass 3 push buttons</p> </div> <div style="text-align: center;">  <p><b>3331 24</b> Stainless steel <b>3331 25</b> Polished brass 2 push buttons</p> </div> <div style="text-align: center;">  <p><b>3331 14</b> Stainless steel <b>3331 15</b> Polished brass 1 push button</p> </div> </div>		
<div style="text-align: center;">  <p>For quotations and technical support <b>contact us on +44 (0) 870 608 9022</b></p> </div>	<p><b>Push button expansion covers</b></p> <div style="display: flex; justify-content: space-around; align-items: flex-start;"> <div style="text-align: center;">  <p><b>3332 04</b> Stainless steel <b>3332 05</b> Polished brass 12 push buttons</p> </div> <div style="text-align: center;">  <p><b>3332 84</b> Stainless steel <b>3332 85</b> Polished brass 8 push buttons</p> </div> </div> <p><b>Video / audio keypad covers</b></p> <div style="display: flex; justify-content: space-around; align-items: flex-start;"> <div style="text-align: center;">  <p><b>3339 34</b> Stainless steel <b>3339 35</b> Polished brass Video</p> </div> <div style="text-align: center;">  <p><b>3337 24</b> Stainless steel <b>3337 25</b> Polished brass Audio</p> </div> </div> <p><b>For code lock and other equipment</b></p> <div style="display: flex; justify-content: space-around; align-items: flex-start;"> <div style="text-align: center;">  <p><b>3336 14</b> Stainless steel <b>3336 15</b> Polished brass</p> </div> <div style="text-align: center;">  <p><b>3330 14</b> Stainless steel <b>3330 15</b> Polished brass</p> </div> </div>		

1 : Can also be used with speaker + scrolling function module (Cat. Nos. 3426 20 and 3426 30)

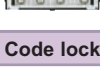

BOXES AND CHASSIS	FUNCTION MODULES
 <p><b>3311 30</b> 3 modules</p> <p><b>3311 20</b> 2 modules</p>	<p style="text-align: center;"><b>Video – cameras, speakers and push buttons</b></p>  <p><b>3425 10</b> Black and white infrared camera</p>  <p><b>3425 50</b> Colour camera</p>  <p><b>3421 70</b> Speaker + 2 push buttons</p>  <p><b>3422 40</b> 4 individual push buttons</p> <p>2 modules } 3 modules</p>
 <p><b>3311 30</b> 3 modules</p> <p><b>3311 20</b> 2 modules</p> <p><b>3311 10</b> 1 module</p>	<p style="text-align: center;"><b>Audio – speakers and push buttons</b></p>  <p><b>3421 70</b> Speaker + 2 push buttons</p>  <p><b>3422 40</b> 4 individual push buttons</p>  <p><b>3422 40</b> 4 individual push buttons</p> <p>1 module } 2 modules } 3 modules</p>
 <p><b>3311 30</b> 3 modules</p> <p><b>3311 20</b> 2 modules</p>	<p style="text-align: center;"><b>Push button expansion modules</b></p>  <p><b>3422 40</b> 4 individual push buttons</p>  <p><b>3422 40</b> 4 individual push buttons</p>  <p><b>3422 40</b> 4 individual push buttons</p> <p>1 module } 2 modules } 3 modules</p>
 <p><b>3311 30</b> 3 modules</p> <p><b>3311 20</b> 2 modules</p>	<p style="text-align: center;"><b>Video / audio – cameras, speakers and keypad</b></p>  <p><b>3425 10</b> Black and white infrared camera</p>  <p><b>3425 50</b> Colour camera</p>  <p><b>3421 70</b> Speaker + 2 push buttons</p>  <p><b>3426 00</b> Alphanumeric digital keypad</p> <p>2 modules } 3 modules</p>
 <p><b>3311 10</b> 1 module</p>	<p style="text-align: center;"><b>Code lock</b></p>  <p><b>3326 50</b> Code lock</p>

# Bticino digital function modules

for Sfera monobloc entrance panels



Selection charts p. 19

**Digital function modules are compatible with Sfera monobloc entrance panels**

Pack	Cat. Nos.	Speaker modules
1	3425 60	<b>Audio/video speaker module</b> 2 push buttons (1 column or 2 columns) including colour camera with LED lighting for night visibility Camera angle of lens on the horizontal axis can be set at $\pm 15^\circ$
1	3421 70	<b>Digital speaker modules</b> The name plates are illuminated by 8 green LEDs 2 push buttons and an additional push button for trade function
1	3423 50	4 push buttons (2 columns)
1	3469 91	<b>Universal speaker unit</b> For use with vandal resistant bespoke entrance panels
<b>Push button modules</b>		
1	3422 40	Connects to the system using cable (supplied) Name plates are illuminated by 12 green LEDs 4 push button module
1	3424 80	8 push button module (2 columns)
1	3469 92	Additional 8 push buttons for expansion of Cat. No. 3469 91
<b>Camera modules</b>		
1	3425 10	For video systems with IR lighting for night visibility In the installation phase the angle of the lens on the horizontal axis can be set at $\pm 20^\circ$ and on the vertical axis at $\pm 15^\circ$ <b>Black and white camera module</b>
1	3425 50	<b>Colour camera module</b>

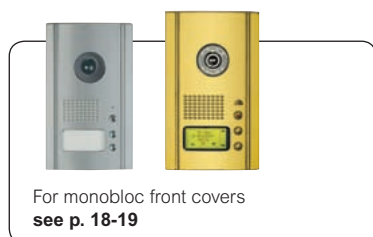





Pack	Cat. Nos.	Miscellaneous modules
1	3426 30	<b>Digital call speaker module with graphic display</b> Digital alphanumeric call + speaker module Can send the call to a handset by scrolling residents' names or codes on a display using dedicated keys Combines the functions of digital speaker module and alphanumeric display in a single device Module can save up to 1 000 residents' names and surnames associating them to the apartment SCS address 500 names can be saved when the possibility of coupling a message with them is chosen If only the residents' codes are saved, capacity extends to 5000 codes <b>NOTE:</b> Can be programmed using a PC with the TICALL software (can be downloaded free from the website <a href="http://www.bticino.co.uk">www.bticino.co.uk</a> ) and the suitable interface Cat. No. 3359
1	3426 40	<b>Additional alphanumeric keypad module</b> Use with module Cat. No. 3426 30 Call the resident directly (by typing the programmed code) and activate the "open door lock" function (by typing the secret code) Supplied with cable and connector for connection to the speaker module
1	3422 00	<b>Name plate module</b> Use to display the street number or any other information Can be used to display a caption in entrance panels with numeric call module Cat. No. 3426 10
1	3426 00	<b>Alphanumeric digital call module</b> Send the call choosing the name of the handset in a list which is shown on a display The module can also activate the door lock by means of a secret code number Supplied with cable for connection to the speaker module
1	3426 10	<b>Numeric digital call module</b> Make calls from the entrance panel to handsets by keying in the number corresponding to the handset required The correspondence between the numbers and the user names is found from a phone book by the side of the module and made up of name plate modules Cat. No. 3422 00 From 1 to 4 numbers may be keyed in to make the call, as programmed by the installer Activate the electric door lock by means of a secret code number Supplied with cable for connection to the speaker module
1	3426 50	<b>Code lock module</b> For door lock activation

## Bticino monobloc entrance panels - vandal resistant scrolling display (Sfera)



## Bticino monobloc entrance panels - vandal resistant push button panels



VIDEO SCROLLING PANELS	FUNCTION MODULES
 <p>3339 14</p> <p>3339 15</p>	 <p>3425 10 or 3425 50 Camera module</p>  <p>3426 30 Speaker + scrolling function/screen</p> <p><b>Keypad</b> Included with Cat. No. 3339 15</p> <p><b>Supplied with flush mounting back box</b> For surface mounting boxes (with rainshield), order Cat. No. AVS915SB for 3339 15 AVS914SB for 3339 14</p>
AUDIO SCROLLING PANELS	FUNCTION MODULES
 <p>3337 14</p> <p>3337 15</p>	 <p>3426 30 Speaker + scrolling function/screen</p> <p><b>Keypad</b> Included with Cat. No. 3337 15</p> <p><b>Supplied with flush mounting back box</b> For surface mounting boxes (with rainshield), order Cat. No. AVS715SB for 3337 15 AVS714SB for 3337 14</p>

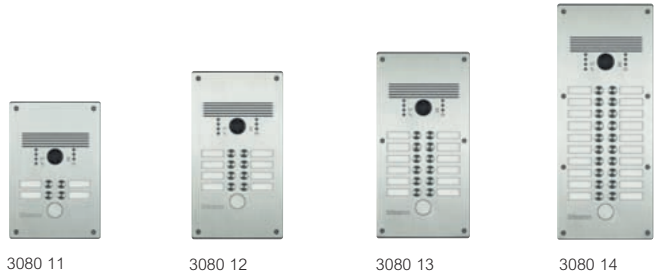

 Dimensions and technical data p. 34

Pack	Cat. Nos.	Vandal resistant push button panels
		Monobloc vandal resistant IP 44 - IK 07 Stainless steel finish colour video push button entrance panels for flush mounting or surface mounting installation (surface mounting boxes ordered separately, see below)
		<b>Colour video push button panels</b> Supplied with : • flush mounting box • frame • colour video and audio electronic module • pre-wired push button module/s Pre-setting for the mounting of transponder reader or key switch. Backlit call keys Visual and sound notifications of the communication status for : call active, system busy, door lock status
1	3080 11	Push button panel for 2 and 4 calls
1	3080 12	Push button panel for up to 8 calls
1	3080 13	Push button panel for up to 12 calls
1	3080 14	Push button panel for up to 20 calls
		<b>Surface mounting boxes</b>
1	3080 21	For use with Cat. No. 3080 11
1	3080 22	For use with Cat. No. 3080 12
1	3080 23	For use with Cat. No. 3080 13
1	3080 24	For use with Cat. No. 3080 14
1	3080 25	For use with Cat. No. 3080 15

### Example of modularity

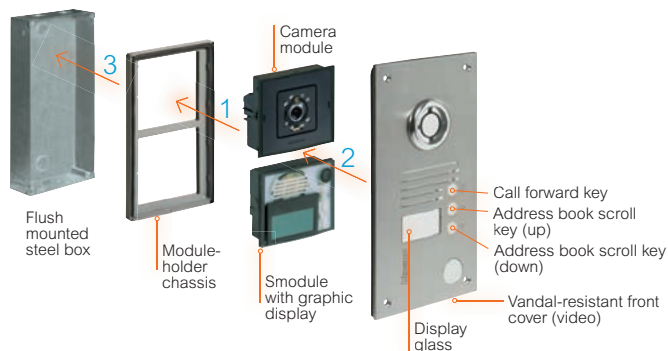

 Dimensions and technical data p. 34

**Bticino entrance panels –  
vandal resistant**  
push button panels (Linea 2000 metal)



3429 81  
3429 91      3429 82  
3429 92      3429 71      3429 72

**Bticino entrance panels –  
with motorised camera**  
electronic push button panels (Axolute)



3393 13      3392 13      3491 40      3484 02

Dimensions and technical data p. 34

Pack	Cat. Nos.	<b>Vandal resistant push button panels (Linea 2000 metal)</b>
		Surface mounting plug and play entrance panels
		<b>Colour video push button panels</b> Zamak finish video push button panels with adjustable colour camera Swivel camera on 2 axis Blue LED name plate light
1	3429 91	1 push button
1	3429 92	2 push buttons
		<b>Black and white video push button panels</b> Zamak finish video push button panels with adjustable black and white camera Swivel camera on 2 axis Blue LED name plate light
1	3429 81	1 push button
1	3429 82	2 push buttons
		<b>Audio push button panels</b> Zamak finish audio push button panels Blue LED name plate light
1	3429 71	1 push button
1	3429 72	2 push buttons

Dimensions and technical data p. 34

Pack	Cat. Nos.	<b>Electronic push button panels for IP system (Axolute)</b>
		<b>Colour video electronic push button panel</b>
1	3491 40	Suitable for use in IP systems IP 54 IK 07 Fitted with : •capacitive soft touch control backlit keypad •motorised colour camera (swivel operation can be controlled from the pre-set handsets) •colour display with home page that can be fully customised by the installer •transponder reader for door lock release – may also be activated using a numeric code for residents Module to be installed with flush mounting box, Cat. No. 3393 13, and surround plate, Cat. Nos. 3392 13 (steel), or 3392 23 (brass) TiAxolute Outdoor and TiContacts programming software, residents' address book creation, and configuration supplied By locally installing a permanent cable with RJ45 socket (T568B type cross connection), it is possible to update the residents address book and the configuration, without removing the push button panel
		<b>Surround plate and frame</b> 3 module Anti-tamper assembly/disassembly safety key supplied
1	3392 13	Steel finish
1	3392 23	Brass finish
		<b>Flush mounting box</b> With tearing protection 3 module
		<b>Transponder keys and programme</b>
1	3482 00	Black transponder key
1	3482 01	Red transponder key
1	3482 02	Green transponder key
1	3482 03	Blue transponder key
1	3482 04	Orange transponder key
1	3482 05	Grey transponder key
1	3482 06	Yellow transponder key
1	3484 02	Table-top transponder key programmer







# Bticino internal units and handsets

multifunctional and video



5739 63



3493 20



3441 82

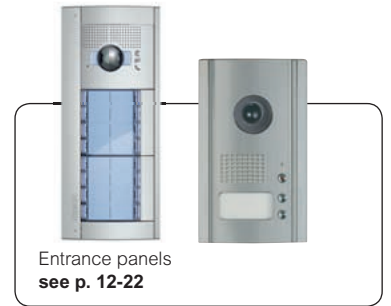

Entrance panels  
see p. 12-22



5739 50



3448 24



3448 32

Dimensions and technical data p. 36-37

Pack	Cat. Nos.	Multifunctional internal units
		<b>10" multimedia touch screens (Arteor)</b> Equipped with white or magnesium cover plate, to be equipped with special plates (see below) 10" touch screen for the control of the house : <ul style="list-style-type: none"> <li>• all BUS functions</li> <li>• door entry system</li> <li>• multimedia (web, radio, webcam...)</li> </ul> Surface mounting
1	5739 62	White
1	5739 63	Magnesium
		<b>8" multifunctional display screens (Axolute)</b> Hands free surface mounting internal unit for use with 2 wire video installations 8" LCD colour screen with OSD (On Screen Display) menu Can be fully integrated with the BUS/SCS system (p. 50-67)
1	3493 20	Axolute Nighter (black)
1	3493 21	Axolute Whice (white)
		<b>2.5" multifunctional display screens</b> Hands free flush mounting internal unit 2.5" LCD colour display with OSD (On Screen Display) menu Can be fully integrated with the BUS/SCS system (p. 50-67) To be equipped with special plates (p. 136-137) To be installed in flush mounting box Cat. No. 0893 79 or 0892 79
1	5739 50	White
1	5739 51	Magnesium

Pack	Cat. Nos.	Video internal units
		<b>Video internal unit (Polyx)</b> Surface mounting video internal unit with 3.5" monitor Door lock push button and 4 programmable push buttons (0-1-2-3) configurable for a choice of functions Handset has the following functions : <ul style="list-style-type: none"> <li>• bell adjustment and exclusion</li> <li>• inductive loop to allow the use for people with impaired hearing</li> </ul>
1	3441 82	
		<b>Video handsets</b>
		<b>Colour video handset (Swing)</b> Swing video handset with 4" colour TFT monitor A choice of 16 types of pre-programmed ring tones Door lock push button and 4 programmable push buttons (0-1-2-3) configurable for a choice of functions Handset has the following functions : <ul style="list-style-type: none"> <li>• bell adjustment and exclusion</li> <li>• inductive loop to allow the use for people with impaired hearing</li> <li>• door lock status LED</li> </ul>
1	3448 24	
		<b>Black and white video handset (Swing)</b> As above Cat. No. 3448 24 but with 4" black and white monitor
1	3448 32	

Pack	Cat. Nos.	Surround plates
		<b>For 10" multimedia touch screens</b>
1	5765 10	● Gold brass
1	5765 13	● Black
1	5765 14	● White
1	5765 16	● Stainless steel
1	5765 17	● Woven metal
		<b>For 2.5" multimedia display screens</b>
1	5764 80	● Gold brass
1	5764 83	● Black
1	5764 84	● White
1	5764 86	● Stainless steel
1	5764 87	● Woven metal



Arteor building automation system  
see p. 50

**Bticino internal units and handsets**  
audio



**Bticino switchboard**



3440 82



3462 10



3447 04



3442 02



Entrance panels  
see p. 12-22



Dimensions and technical data p. 37

Pack	Cat. Nos.	Audio internal units
		<b>Audio hands free internal unit (Arteor)</b> Flush mounting Volume adjustment for communication and call tone, and with bell cut-off indicator Allows intercom between several rooms Supplied complete with special flush-mounting box, cover plate and plate
1	5740 11	White (supplied with white plate)
1	5743 11	Magnesium (supplied with mirror black plate)
		<b>Audio internal unit (Polyx)</b>
1	3440 82	Surface mounting Door lock push button and 4 programmable push buttons (0-1-2-3) configurable for a choice of functions Handset has the following functions : • bell adjustment and exclusion • inductive loop to allow the use for people with impaired hearing • door lock status LED

Pack	Cat. Nos.	Switchboard and accessories
		<b>Switchboard</b> For 2 wire audio and video systems Access to various services directly from the keyboard or using the intuitive menu icons : • video door entry system functions • door lock and/or stair light management • monitoring of apartment alarms) Switchboard is supplied with : • built-in table top support • 7" colour LCD display receiver • handsfree, dedicated keys for the main functions • configurable keys Programming can be performed directly from the device, or using a PC with the software (supplied as standard)
1	3463 10	White 8-way socket, for table top installation of switchboard Cat. No. 346310 (above)
1	3369 82	Cable (AMP-RJ) for table top installation of switchboard Cat. No. 346310 (above)

Pack	Cat. Nos.	Audio handsets
		<b>Audio handset (Swing)</b> A choice of 16 types of pre-programmed ring tones Door lock push button and 4 programmable push buttons (0-1-2-3) configurable for a choice of functions Bell volume can be adjusted and excluded Handset has the following functions : • bell adjustment and exclusion • inductive loop to allow the use for people with impaired hearing • door lock status LED
1	3447 04	
		<b>Audio handsets (Sprint)</b> With door lock push button Call volume can be set to 3 levels
1	3442 02	
1	3442 12	With door lock push button and a push button for auxiliary functions Call volume can be set to 3 levels



Arteor building automation system  
see p. 50

# Bticino system components



Pack	Cat. Nos.	Power supply units
1	3460 00	For audio or video installations – 8 DIN rail modules 1200 mA
1	3460 20	Compact unit for audio or video installations – 2 DIN rail modules 600 mA Suitable only to feed additional handsets or entrance panels
1	3460 30	Compact unit with video adaptor – 2 DIN rail modules 600 mA

Pack	Cat. Nos.	Relays
1	3462 00	<b>Staircase light timer relay</b> 4 DIN rail modules
1	3462 30	<b>Digital remote secure door lock relay</b> 2 DIN rail modules
1	3462 50	<b>Digital relay – NC/NO contact</b> Can be added in entrance panel back box
1	3462 60	<b>Digital timer relay</b> With electro-magnetic locks management, temporised door opening and lock states signalling – 4 DIN rail modules

Pack	Cat. Nos.	Video accessories
1	3468 30	<b>Video adaptor</b> Use with power supply Cat. No. 3460 00 in video installations
1	5739 98	<b>Audio/video node</b> For mixing audio/video sources, max. 4 sources – 6 DIN rail modules Note : to be used as an alternative to video adaptor Cat. No. 3468 30
1	3468 41	<b>Video floor distribution block</b> 4 outputs
1	3474 00	<b>Remote camera interface</b> Input module for external camera
1	3468 70	<b>Video amplifier</b> For systems installed with non-twisted cables (100 m max.)
1	F442	<b>Video TV interface</b>

Pack	Cat. Nos.	Interface with other systems
1	3461 50	<b>8 wire/2 wire interface</b> 6 DIN rail modules
1	3494 10	<b>Analogue/2 wire interface</b>
1	3468 90	<b>IP/2 wire interface</b> 10 DIN rail modules

Pack	Cat. Nos.	Expansion interfaces
1	3468 50	<b>Apartment interface</b> Connects an independent video door entry system and Arteor home system application in the apartment with the apartment block riser The use of the internal installation within the apartment does not occupy the main block riser – 4 DIN rail modules
1	3468 51	<b>Installation expansion module</b> Allows increase in distance between entrance panel and handset, increase in number of devices installed, creation of risers with independent entrance panels – 4 DIN rail modules

Pack	Cat. Nos.	Bell accessories
1	3369 10	Additional bell
1	3468 33	Floor call input device for door bell

Pack	Cat. Nos.	Other accessories
1	3469 02	<b>Connection cable</b> For connection of push buttons within entrance panel
1	3469 03	<b>Connector</b> For entrance panels with more than 26 push buttons
1	5739 99	<b>Bus cable</b> 2 conductor cable (200 m coil)

Pack	Cat. Nos.	Configurators
1	0492 00	No. 0 (pack of 10)
1	0492 01	No. 1 (pack of 10)
1	0492 02	No. 2 (pack of 10)
1	0492 03	No. 3 (pack of 10)
1	0492 04	No. 4 (pack of 10)
1	0492 05	No. 5 (pack of 10)
1	0492 06	No. 6 (pack of 10)
1	0492 07	No. 7 (pack of 10)
1	0492 08	No. 8 (pack of 10)
1	0492 09	No. 9 (pack of 10)
1	0492 18	SLA (pack of 10)
1	0492 10	GEN (pack of 10)
1	3060 64	Configurator kit – 10 internal units
1	3060 65	Configurator kit – 20 internal units
1	0261 45	Configurator site kit consists of : – 10 pcs for 0 to 9 – 2 blue extractable connectors with 8 terminals – 2 green extractable connectors with 2 terminals – 1 tweezers – 1 plastic screwdriver



**MaxiRex and EconoRex  
analogue time switches**  
surface and panel mounting



0497 54



0499 83

Pack	Cat. Nos.	MaxiRex time switches
		Conform to EN 60730-1 and EN 60730-2-7 Supply voltage : 230 V~ ±10% 3 position changeover switch With manual override Voltage free contacts Mounting options : - can be surface mounted - can be panel mounted using Cat. No. 0498 32 - can be clipped to DIN rail using Cat. No. 0044 09 With 72 x 72 mm display to DIN EN 60715 Part C <b>24 hour programme</b> Programmable for 30 minutes minimum at 10 minute intervals Accuracy : ±5 minutes per day
1	0497 50	<b>MaxiRex T</b> Without working reserve – 50 Hz
1	0497 54	<b>MaxiRex QT</b> With 100 hr working reserve – 50/60 Hz <b>7 day programme</b> Programmable for 3 hours minimum at 1 hour intervals Accuracy : ±30 minutes per day
5	0498 32	<b>Fixing accessories</b> Clip-on support frame for panel mounting
5	0044 09	DIN rail adaptor

Pack	Cat. Nos.	EconoRex MT time switches
		Conforms to EN 60730-1 and EN 60730-2-7 Supply voltage : 230 V~ 50 Hz Mounting options : - can be surface mounted using Cat. No. 0495 94 - can be panel mounted
1	0499 83	<b>EconoRex MT</b> BTAP without working reserve 20 A output Shortest switching step : 20 minutes Switching accuracy : ± 5 minutes
1	0495 94	<b>Fixing accessory</b> Support frame for surface mounting

Pack	Cat. Nos.	MicroRex D time switches	No. of 17.5 mm modules
1	0037 00	Supply voltage : 230 V~ 50/60 Hz Working reserve : 100 hours Accuracy : ±2.5 seconds per day <b>MicroRex D11 – 1 module</b> 8 programmes 1 channel 1 x 16 A – 250 V~ voltage free c/o contacts with 8 "ON-OFF" per day or per week	1

For other time switches refer to the Industrial and power protection catalogue...  
**Contact us on +44 (0) 845 605 4333**



**Bticino IP system**



5740 39



5740 43

Pack	Cat. Nos.	IP interface
1	5740 39	For extended systems with IP backbone and 2 wire support - 10 DIN rail modules
1	5740 43	Virtual switchboard software For managing entryphone and video entryphone calls The software (for Windows operating systems) can be installed on any fixed or mobile PC and is used to receive, manage and transfer calls from inside and outside Offers home video control with cyclical CCTV vision, day and night functions and the ability to display the alarms present in the various apartments - Operating systems supported : Microsoft Windows XP Service Pack 2 and Windows Vista - Software required : NET Framework 2.0 or later
1	3461 50	<b>Interface with other systems</b> 8 wire/2 wire interface - 6 DIN rail modules

**IP - the future of door entry**



Combining the latest IP technology with Bticino's 2 wire range creates systems with outstanding capabilities...

- Up to 10,000 apartments
- Up to 1,000 entrance panels



## Bticino 2 wire door entry systems composition table

colour video - new Sfera modular entrance panels (Star Wiring)



No. of calls	Box + chassis (Flush mounting)			Support frames and surround plates			Function modules and accessories			Modular front covers					Power supply + video adapter		Video floor distribution block	Video handsets				
	3500 10	3500 20	3500 30	3502 11	3502 21	3502 31	3513 00	3520 00	3540 00	3513 01	3513 11	3520 31	3520 41	3523 01	3460 00	3468 30		3468 41	Swing	Polyx display	Arteor display White finish <sup>®</sup>	Arteor display Magnesium finish <sup>®</sup>
1 <sup>(2)</sup>	1	-	-	1	-	-	1	-	-	-	1	-	-	-	1	1	1	Any combination up to 1, 2, 3, 4, 5, etc				
2 <sup>(2)</sup>	-	1	-	-	1	-	1	1	-	1	-	1	-	-	1	1	1	Any combination up to 1, 2, 3, 4, 5, etc				
3 <sup>(2)</sup>	-	1	-	-	1	-	1	1	-	1	-	1	-	-	1	1	1	Any combination up to 1, 2, 3, 4, 5, etc				
4 <sup>(2)</sup>	-	1	-	-	1	-	1	1	-	1	-	-	1	-	1	1	1	Any combination up to 1, 2, 3, 4, 5, etc				
5 <sup>(2)</sup>	-	1	-	-	1	-	1	1	-	-	1	-	1	-	1	1	1	Any combination up to 1, 2, 3, 4, 5, etc				
6 <sup>(2)</sup>	-	-	1	-	-	1	1	2	-	1	-	1	1	-	1	1	2	Any combination up to 1, 2, 3, 4, 5, etc				
7 <sup>(2)</sup>	-	-	1	-	-	1	1	2	-	1	-	1	1	-	1	1	2	Any combination up to 1, 2, 3, 4, 5, etc				
8 <sup>(2)</sup>	-	-	1	-	-	1	1	2	-	1	-	-	2	-	1	1	2	Any combination up to 1, 2, 3, 4, 5, etc				
9 <sup>(2)</sup>	-	-	1	-	-	1	1	2	-	-	1	-	2	-	1	1	2	Any combination up to 1, 2, 3, 4, 5, etc				
10 <sup>(2)</sup>	-	2	-	-	2	-	1	3	1	1	-	1	2	-	1	1	3	Any combination up to 1, 2, 3, 4, 5, etc				
11 <sup>(3)</sup>	-	2	-	-	2	-	1	3	1	1	-	1	2	-	1	1	3	Any combination up to 1, 2, 3, 4, 5, etc				
12 <sup>(3)</sup>	-	2	-	-	2	-	1	3	1	1	-	-	3	-	1	1	3	Any combination up to 1, 2, 3, 4, 5, etc				
13 <sup>(3)</sup>	-	2	-	-	2	-	1	3	1	-	1	-	3	-	1	1	3	Any combination up to 1, 2, 3, 4, 5, etc				
14 <sup>(3)</sup>	-	-	2	-	-	2	1	4	1	1	-	1	3	1	1	1	4	Any combination up to 1, 2, 3, 4, 5, etc				
15 <sup>(3)</sup>	-	-	2	-	-	2	1	4	1	1	-	1	3	1	1	1	4	Any combination up to 1, 2, 3, 4, 5, etc				
16 <sup>(3)</sup>	-	-	2	-	-	2	1	4	1	1	-	-	4	1	1	1	4	Any combination up to 1, 2, 3, 4, 5, etc				
17 <sup>(3)</sup>	-	-	2	-	-	2	1	4	1	-	1	-	4	1	1	1	4	Any combination up to 1, 2, 3, 4, 5, etc				
18 <sup>(3)</sup>	-	-	2	-	-	2	1	5	1	1	-	1	4	-	1	1	5	Any combination up to 1, 2, 3, 4, 5, etc				
19 <sup>(3)</sup>	-	-	2	-	-	2	1	5	1	-	-	1	4	-	1	1	5	Any combination up to 1, 2, 3, 4, 5, etc				
20 <sup>(3)</sup>	-	-	2	-	-	2	1	5	1	-	-	-	5	-	1	1	5	Any combination up to 1, 2, 3, 4, 5, etc				

(1) Arteor display internal units require cover plates, see p. 23  
 (2) Please add configurator Cat. No. 3060 64 to the system composition  
 (3) Please add configurator Cat. No. 3060 65 to the system composition

This table is indicative only, exact requirements may vary depending on project configuration. Further technical support is available by calling +44 (0) 870 608 9022

# Bticino 2 wire door entry systems composition table

colour video - new Sfera ROBUR modular entrance panels (Star Wiring)



No. of calls	Box + chassis (Flush mounting)			Support frames and surround plates			Function modules and accessories			Modular front covers					Power supply + video adapter		Video floor distribution block	Video handsets				
	3501 10	3501 20	3501 30	3503 15 + 3504 15	3503 25 + 3504 25	3503 35 + 3504 35	3513 00	3520 00	3540 00	3513 05	3513 15	3520 35	3520 45	3523 05	3460 00	3468 30		3468 41	Swing	Polyx display	Arteor display White finish <sup>(1)</sup>	Arteor display Magnesium finish <sup>(1)</sup>
1 <sup>(2)</sup>	1	-	-	1	-	-	1	-	-	-	1	-	-	-	1	1	1	Any combination up to 1, 2, 3, 4, 5, etc				
2 <sup>(2)</sup>	-	1	-	-	1	-	1	1	-	1	-	1	-	-	1	1	1	Any combination up to 1, 2, 3, 4, 5, etc				
3 <sup>(2)</sup>	-	1	-	-	1	-	1	1	-	1	-	1	-	-	1	1	1	Any combination up to 1, 2, 3, 4, 5, etc				
4 <sup>(2)</sup>	-	1	-	-	1	-	1	1	-	1	-	-	1	-	1	1	1	Any combination up to 1, 2, 3, 4, 5, etc				
5 <sup>(2)</sup>	-	1	-	-	1	-	1	1	-	-	1	-	1	-	1	1	1	Any combination up to 1, 2, 3, 4, 5, etc				
6 <sup>(2)</sup>	-	-	1	-	-	1	1	2	-	1	-	1	1	-	1	1	2	Any combination up to 1, 2, 3, 4, 5, etc				
7 <sup>(2)</sup>	-	-	1	-	-	1	1	2	-	1	-	1	1	-	1	1	2	Any combination up to 1, 2, 3, 4, 5, etc				
8 <sup>(2)</sup>	-	-	1	-	-	1	1	2	-	1	-	-	2	-	1	1	2	Any combination up to 1, 2, 3, 4, 5, etc				
9 <sup>(2)</sup>	-	-	1	-	-	1	1	2	-	-	1	-	2	-	1	1	2	Any combination up to 1, 2, 3, 4, 5, etc				
10 <sup>(2)</sup>	-	2	-	-	2	-	1	3	1	1	-	1	2	-	1	1	3	Any combination up to 1, 2, 3, 4, 5, etc				
11 <sup>(3)</sup>	-	2	-	-	2	-	1	3	1	1	-	1	2	-	1	1	3	Any combination up to 1, 2, 3, 4, 5, etc				
12 <sup>(3)</sup>	-	2	-	-	2	-	1	3	1	1	-	-	3	-	1	1	3	Any combination up to 1, 2, 3, 4, 5, etc				
13 <sup>(3)</sup>	-	2	-	-	2	-	1	3	1	-	1	-	3	-	1	1	3	Any combination up to 1, 2, 3, 4, 5, etc				
14 <sup>(3)</sup>	-	-	2	-	-	2	1	4	1	1	-	1	3	1	1	1	4	Any combination up to 1, 2, 3, 4, 5, etc				
15 <sup>(3)</sup>	-	-	2	-	-	2	1	4	1	1	-	1	3	1	1	1	4	Any combination up to 1, 2, 3, 4, 5, etc				
16 <sup>(3)</sup>	-	-	2	-	-	2	1	4	1	1	-	-	4	1	1	1	4	Any combination up to 1, 2, 3, 4, 5, etc				
17 <sup>(3)</sup>	-	-	2	-	-	2	1	4	1	-	1	-	4	1	1	1	4	Any combination up to 1, 2, 3, 4, 5, etc				
18 <sup>(3)</sup>	-	-	2	-	-	2	1	5	1	1	-	1	4	-	1	1	5	Any combination up to 1, 2, 3, 4, 5, etc				
19 <sup>(3)</sup>	-	-	2	-	-	2	1	5	1	-	-	1	4	-	1	1	5	Any combination up to 1, 2, 3, 4, 5, etc				
20 <sup>(3)</sup>	-	-	2	-	-	2	1	5	1	-	-	-	5	-	1	1	5	Any combination up to 1, 2, 3, 4, 5, etc				





















(1) Arteor display internal units require cover plates, see p. 23  
 (2) Please add configurator Cat. No. 3060 64 to the system composition  
 (3) Please add configurator Cat. No. 3060 65 to the system composition

This table is indicative only, exact requirements may vary depending on project configuration. Further technical support is available by calling +44 (0) 870 608 9022

## Bticino 2 wire door entry systems composition table

audio - new Sfera modular entrance panels



No. of calls	Box + chassis (Flush mounting)			Surround plates <sup>(1)</sup>			Speaker module and power supply		Push button module		Modular front covers						Audio handsets					
																					Arteor hands free	
																					White	Magnesium
1 <sup>(1)</sup>	1	-	-	1	-	-	1	1	-	-	-	1	-	-	-	-	1	or 1	or 1	or 1	or 1	or 1
2 <sup>(1)</sup>	1	-	-	1	-	-	1	1	-	-	-	-	1	-	-	-	2	or 2	or 2	or 2	or 2	or 2
3 <sup>(1)</sup>	-	1	-	-	1	-	1	1	1	-	1	-	-	1	-	-	3	or 3	or 3	or 3	or 3	or 3
4 <sup>(1)</sup>	-	1	-	-	1	-	1	1	1	-	1	-	-	-	1	-	4	or 4	or 4	or 4	or 4	or 4
5 <sup>(1)</sup>	-	1	-	-	1	-	1	1	1	-	-	1	-	-	1	-	5	or 5	or 5	or 5	or 5	or 5
6 <sup>(1)</sup>	-	1	-	-	1	-	1	1	1	-	-	-	1	-	1	-	6	or 6	or 6	or 6	or 6	or 6
7 <sup>(1)</sup>	-	-	1	-	-	1	1	1	2	-	1	-	-	1	1	-	7	or 7	or 7	or 7	or 7	or 7
8 <sup>(1)</sup>	-	-	1	-	-	1	1	1	2	-	1	-	-	-	2	-	8	or 8	or 8	or 8	or 8	or 8
9 <sup>(1)</sup>	-	-	1	-	-	1	1	1	2	-	-	1	-	-	2	-	9	or 9	or 9	or 9	or 9	or 9
10 <sup>(1)</sup>	-	-	1	-	-	1	1	1	2	-	-	-	1	-	2	-	10	or 10	or 10	or 10	or 10	or 10
11 <sup>(2)</sup>	-	2	-	-	2	-	1	1	3	1	1	-	-	1	2	-	11	or 11	or 11	or 11	or 11	or 11
12 <sup>(2)</sup>	-	2	-	-	2	-	1	1	3	1	1	-	-	-	3	-	12	or 12	or 12	or 12	or 12	or 12
13 <sup>(2)</sup>	-	2	-	-	2	-	1	1	3	1	-	1	-	-	3	-	13	or 13	or 13	or 13	or 13	or 13
14 <sup>(2)</sup>	-	2	-	-	2	-	1	1	3	1	-	-	1	-	3	-	14	or 14	or 14	or 14	or 14	or 14
15 <sup>(2)</sup>	-	-	2	-	-	2	1	1	4	1	1	-	-	1	3	1	15	or 15	or 15	or 15	or 15	or 15
16 <sup>(2)</sup>	-	-	2	-	-	2	1	1	4	1	1	-	-	-	4	1	16	or 16	or 16	or 16	or 16	or 16
17 <sup>(2)</sup>	-	-	2	-	-	2	1	1	4	1	-	1	-	-	4	1	17	or 17	or 17	or 17	or 17	or 17
18 <sup>(2)</sup>	-	-	2	-	-	2	1	1	4	1	-	-	1	-	4	1	18	or 18	or 18	or 18	or 18	or 18
19 <sup>(2)</sup>	-	-	2	-	-	2	1	1	5	1	1	-	-	1	4	-	19	or 19	or 19	or 19	or 19	or 19
20 <sup>(2)</sup>	-	-	2	-	-	2	1	1	5	1	1	-	-	-	5	-	20	or 20	or 20	or 20	or 20	or 20

(1) Please add configurator Cat. No. 3060 64 to the system composition

(2) Please add configurator Cat. No. 3060 65 to the system composition

This table is indicative only, exact requirements may vary depending on project configuration. Further technical support is available by calling +44 (0) 870 608 9022

**Bticino access control system**



8216 30



8216 31



8210 87

Pack	Cat. Nos.	
		<b>Code lock keypad kit (IP 67)</b>
1	8216 30	Vandal resistant with blue back lit keys 2 relays Users : up to 100 Finish : polished cast aluminium Voltage : 12-48 V DC, 12-24 V AC Current : 80 mA Dimensions : 110 x 75 x 15 mm Code lock keypad (GALEO2R)
		<b>Stand alone proximity reader (IP 53)</b>
1	8216 31 <sup>1</sup>	Self-contained proximity reader/controller Programmed via a master code, the unit has LED and audible indication, with exit button input and timed relay output Accepts a remote read head for higher security Users : up to 500 Finish : ABS Voltage : 12 V AC / DC Current : 80 mA Dimensions : 135 x 76 x 20 mm Stand-alone reader (Promi500)
		<b>Modular proximity kit (Sfera)</b>
1	8210 86 <sup>1</sup>	Kit comprises : - door controller - Sfera modular panel mounting reader - power supply unit - 10 proximity key fobs Reader uses LED and audible indication, exit button input and timed relay output Stand alone 2 door controller kit for up to 500 users with 2 programmable relay outlets and 2 exit button inputs

Pack	Cat. Nos.	
		<b>Additional equipment</b>
1	8210 87	<b>Proximity key fobs</b> Grey proximity key fobs (pack of 10)
		<b>Additional mushroom head reader (IP 67)</b>
1	8210 83	Small profile reader suitable for external use To be used with stand-alone reader Cat. No. 8216 31 or in conjunction with access control kit Cat. No. 8210 86 to replace Sfera modular reader or to control a second door Can be mounted in vandal resistant panels Cat. Nos. 3337 14/15 and 3339 14/15 (p. 46) Can be installed up to 50 metres from the controller Finish : High impact ABS Dimensions : 42 mm head, 25 mm body diameter Operating temperature : -20 to +50° C Mushroom head reader
		<b>Sfera monobloc plates for mushroom head reader</b>
1	8210 84 <sup>2</sup>	Brass
1	8210 85 <sup>2</sup>	Stainless steel
		<b>Additional Sfera modular reader (IP 54)</b>
1	8210 82	Sfera modular panel mounting reader with LED and audible indication To be used in conjunction with access control kit Cat. No. 8210 86 to control a second door Sfera modular reader

2 : Use back box Cat. No. 3311 10

1 : The kit can be used as a stand-alone proximity system or, alternatively, integrated into a Bticino audio/video entrance panel  
For full details of additional equipment and finishes, please contact technical support





## Bticino access control system (continued)



8216 32



8216 35



0380 23

Pack	Cat. Nos.	Locks and accessories
		<b>Surface magnetic locks</b> High quality, surface mount, electromagnetic lock with innovative blue visual end cap Holding force of 300 kg Finish : aluminium Voltage : 12–24 V DC Current : 630 mA/315 mA Dimensions : 253 x 46 x 27 mm Operating temperture : –20 to +50° C
1	8216 32	Surface magnetic lock 300 kg (FAS 300)
1	8210 79	Surface magnetic lock kit - 300 kg (including PSU, Z and L brackets and NC relay)
		<b>Flush magnetic lock</b> Mortice mount electromagnetic lock with a holding force of 300 kg Ideal for locking sliding doors and windows Finish : aluminium Voltage : 12–24 V DC Current : 630 mA at 12 V DC 313 mA at 24 V DC Dimensions : 229 x 38 x 27 mm Operating temperture : –20 to +50° C
1	8216 33	Flush magnetic lock 300 kg (FES 300)
		<b>Latch hammer locks</b>
1	8206 48	Mortice latch hammer 12 V DC
1	8206 50	Rim latch hammer 12 V DC
		<b>Z and L bracket</b> For use with Cat. Nos. 8216 32/33 For universal mounting
1	8216 34	Z and L kit for 300 series (P 300)
		<b>Power supply unit</b> For magnetic locks DC power supply for powering up to 2.0 A at 12 V DC and 2.0 A at 24 V DC These units have charging circuits for standby batteries, and are supplied in metal cases with LED indication
1	8216 35	12 V DC, 2.0 A standard (PSU 122)

Pack	Cat. Nos.	Break glass unit for emergency exit
		IP 40 - IK07 Green Surface mounting Dimensions : 90 x 90 x 57 mm Call by pressing the membrane (pressure 2.5 kg) with clear display of the call position Reset on front of device, with special key (supplied) Space reserved to stick a function using identification label Equipped with NO/NC contact 5 A-24 V~/1 A-48 V~
1	0380 23	Break glass unit for emergency exit

**Bticino door entry kits**

2 wire - with surface mounting vandal resistant entrance panel



**Bticino door entry kits**

2 wire/analogue - with surface mounting entrance panel



3689 11



3675 11



3638 11



3654 11



3681 11



3638 11 packaging

Vandal resistant entrance panel manufactured in Zamak  
Conform to BS EN 60065, BS EN 50081-1 and BS EN 50082-1  
IP 54 audio or video entrance panel

**Guaranteed co-ax free**

Conform to BS EN 60065, BS EN 50081-1 and BS EN 50082-1  
IP 54 audio entrance panel  
All wires centralised at main handset

Pack	Cat. Nos.	<b>Video kits – colour</b>
		<b>With colour hands free internal unit</b> Kit comprises : Linea metal surface video entrance panel with vandal resistant body, colour camera, LED lighting and illuminated name plate(s) Polyx hands free colour video handset(s) Power supply Video adapter
1	3689 11	1 way colour video kit
1	3689 21	2 way colour video kit
		<b>With colour handset</b> Kit comprises : Linea metal surface video entrance panel with vandal resistant body, colour camera, LED lighting and illuminated name plate(s) Swing colour video handset(s) Power supply Video adapter
1	3675 11	1 way colour video kit
1	3675 21	2 way colour video kit

Pack	Cat. Nos.	<b>Video kits – black and white</b>
		Kit comprises : Linea metal surface video entrance panel with vandal resistant body, black and white camera, infrared lighting and illuminated name plate(s) Swing black and white video handset(s) Power supply Video adapter Door lock relay accessory
1	3654 11	1 way black and white video kit
1	3654 21	2 way black and white video kit

Pack	Cat. Nos.	<b>Audio kits</b>
		Kit comprises : Linea metal surface audio entrance panel with vandal resistant body and illuminated name plate(s) Swing audio handset(s) Power supply
1	3681 11	1 way audio kit
1	3681 21	2 way audio kit

Pack	Cat. Nos.	<b>Audio kits (analogue / 2 wire)</b>
		Kit comprises : Linea series extra slim surface mounting audio entrance panel with pressed aluminium body and illuminated name plate Sprint audio handset Power supply
1	3638 11	1 way audio kit
1	3369 10	Additional bell
1	3315 50	Additional handset (6 wire)
		<b>Audio kits (analogue system)</b> Linea series extra slim surface mounting audio entrance panel with pressed aluminium body and illuminated name plate Sprint audio handset Power supply
1	3632 11	1 way analogue audio kit
1	3632 21	2 way analogue audio kit

## Bticino modular entrance panels

Sfera and Sfera ROBUR

### ■ Entrance panels – Sfera

#### Flush mounting boxes

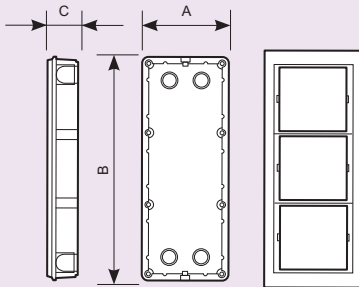

#### Flush mounted boxes – Sfera

Dimensions (mm)			
Cat. Nos.	A	B	C
3500 10	117	123	45
3500 20	117	214	45
3500 30	117	306	45

#### Frames and supports

##### Frames and supports – Sfera

Dimensions (mm)			
Cat. Nos.	Width	Height	Depth
3502 11/12/13	138	144	15
3502 21/22/23	138	235	15
3502 31/32/33	138	327	15

#### Rainshields – optional

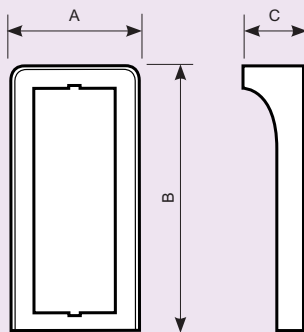

#### Rainshields – Sfera

Dimensions (mm)			
Cat. Nos.	A	B	C
3305 11/12/13	151	151	50
3305 21/22/23	151	242	50
3305 31/32/33	151	334	50
3305 41/42/43	290	242	50
3306 61/62/63	290	334	50
3305 91/92/93	430	334	50

#### Surface mounting boxes with in-built rainshields

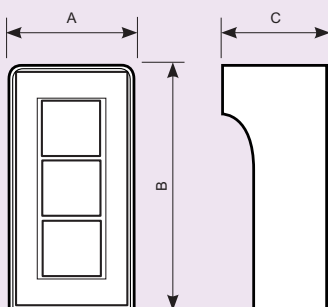

#### Sfera

Dimensions (mm)			
Cat. Nos.	A	B	C
3506 11/12/13	155	160	81
3506 21/22/23	155	255	81
3506 31/32/33	155	360	81
3506 41/42/43	290	255	81
3506 61/62/63	290	360	81
3506 91/92/93	430	360	81

### ■ Entrance panels – Sfera ROBUR

#### Flush mounting boxes

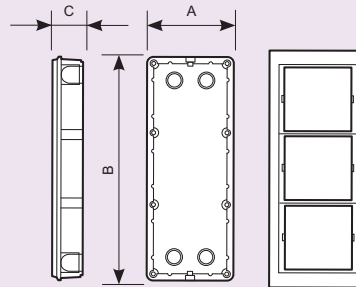

#### Steel flush mounted boxes – Sfera ROBUR

Dimensions (mm)			
Cat. Nos.	A	B	C
3500 10	102	114	51
3500 20	102	206	51
3500 30	102	297	51

With tearing protection

#### Surround plates

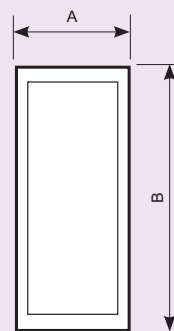

#### Surround plates – Sfera ROBUR

Dimensions (mm)			
Cat. Nos.	A	B	Depth
3504 15	139	144	21
3504 25	139	235	21
3504 35	139	327	21

#### Frames and supports

##### Frames and supports – Sfera ROBUR

Dimensions (mm)			
Cat. Nos.	Width	Height	Depth
3503 15	134	132	34.5
3503 25	134	223	34.5
3503 35	134	315	34.5

#### Surface mounting boxes with in-built rainshields

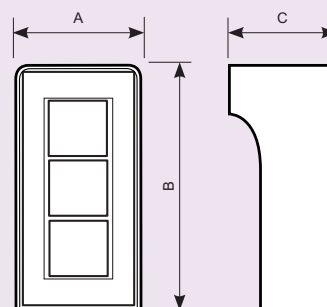

#### Sfera – ROBUR

Dimensions (mm)			
Cat. Nos.	A	B	C
3506 11/12/13	155	160	81
3506 21/22/23	155	255	81
3506 31/32/33	155	360	81
3506 41/42/43	290	255	81
3506 61/62/63	290	360	81
3506 91/92/93	430	360	81

## Bticino entrance panels

monobloc, scrolling display and push button

### ■ Sfera monobloc

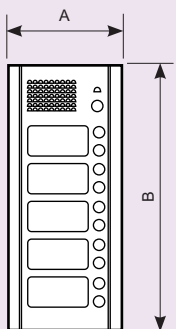

Dimensions (mm)		
No. modules	A	B
1	140	142
2	140	233
3	140	325

### ■ Vandal resistant monobloc – scrolling display (audio)

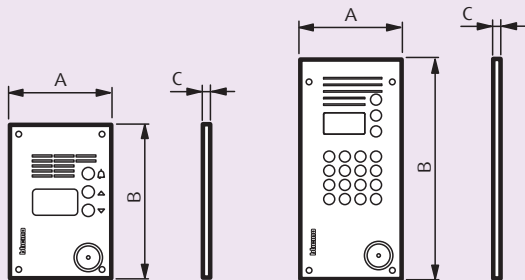

Dimensions (mm)			
Cat. Nos.	A	B	C
3337 14	150	198	4
3337 15	150	283	4

### ■ Vandal resistant monobloc – scrolling display (video)

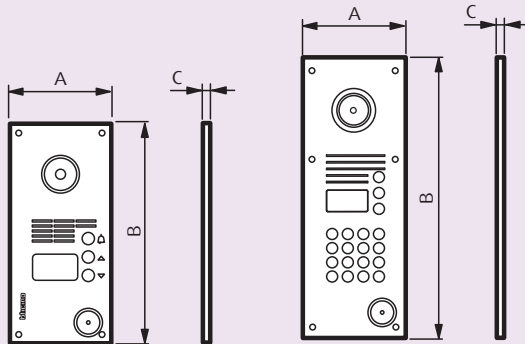

Dimensions (mm)			
Cat. Nos.	A	B	C
3339 14	150	284	4
3339 15	150	401.5	4

### ■ Vandal resistant – push button (LINEA 2000 metal)

#### Colour video

Cat. Nos. 3429 91-3429 92

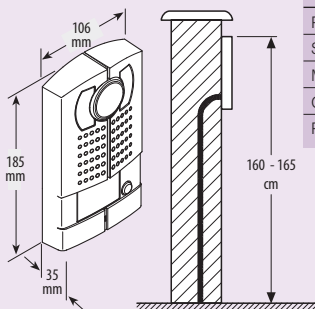

Technical data	
Power supply from SCS BUS:	18-27 Vdc
Standby absorption:	20 mA
Max. operating absorption:	240 mA
Operating temperature:	(-25)-(+70)°C
PI against mechanical impact	IK 07

### ■ Vandal resistant – push button (LINEA 2000 metal) (continued)

#### Black and white video

Cat. Nos. 342981-342982

Technical data	
Power supply from SCS BUS:	18-27 Vdc
Standby absorption:	30 mA
Max. operating absorption:	270 mA
Operating temperature:	(-25)-(+70)°C
PI against mechanical impact	IK 07

#### Audio

Cat. Nos. 342971-342972

Technical data	
Power supply from SCS BUS:	18-27 Vdc
Standby absorption :	30 mA
Max. operating absorption:	65 mA
Operating temperature:	(-25)-(+70)°C
PI against mechanical impact	IK 07

### ■ Vandal resistant monobloc – push button

Cat. Nos. 308011/12/13/14

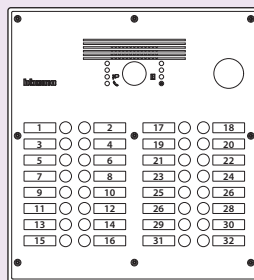

Technical data	
Power supply from SCS BUS:	18-27 Vdc
Standby absorption:	
308011	55 mA
308012	70 mA
308013	85 mA
308014	115 mA
Max. operating absorption:	
308011	175 mA
308012	190 mA
308013	205 mA
308014	235 mA
Camera sensor:	1/3"
Lens:	f1.5 f4.3 mm
Horizontal resolution:	330 lines
Illumination of the veiving field:	White LEDs
Brightness adjustment:	Automatic
Operating temperature:	(-25)-(+70)°C
Protection Index	IP 54
PI against mechanical impact	IK 07

### ■ With motorised camera and push buttons

Cat. No. 349140

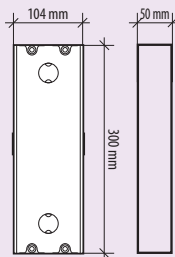

Flush mounted box

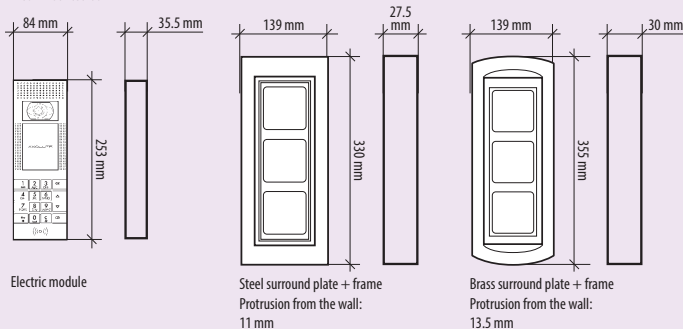

Electric module

Steel surround plate + frame  
Protrusion from the wall:  
11 mm

Brass surround plate + frame  
Protrusion from the wall:  
13.5 mm

## Bticino digital function modules for Sfera modular entrance panels

### ■ Dimensions and technical data

#### Basic speaker module

Cat. No. 3510 00

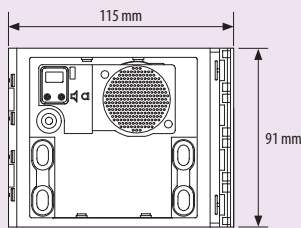

Technical data	
Power supply from SCS BUS	18-27 Vdc
Standby absorption	15 mA
Max. operating absorption	65 mA
Operating temperature	(-25)-(+70)°C
Protection Index (pushbutton panel assembled)	IP 54

#### Speaker module

Cat. No. 3511 00

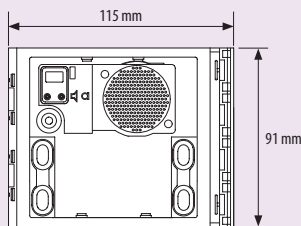

Technical data	
Power supply from SCS BUS	18-27 Vdc
Standby absorption (with backlighting LEDs off)	10 mA
Standby absorption (with backlighting LEDs on)	15 mA
Max. operating absorption	65 mA
Operating temperature	(-25)-(+70)°C
Protection Index (pushbutton panel assembled)	IP 54

#### Audio / video module

Cat. No. 35112 00

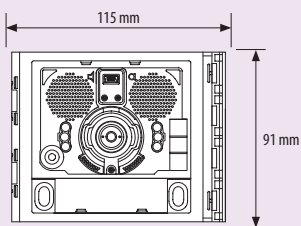

Technical data	
Power supply from SCS BUS	18-27 Vdc
Standby absorption (with backlighting LEDs off)	15 mA
Standby absorption (with backlighting LEDs on)	20 mA
Max. operating absorption	140 mA
Colour sensor	1/3"
Lens	f2.5 f3-3 mm
Resolution	330 TV lines
Illumination of the veiwing field	White LED
Brightness adjustment	Automatic
Interface	2 : 1
Mist prevention heating resistance	
Operating temperature	(-25)-(+70)°C
Protection Index (pushbutton panel assembled)	IP 54

#### Wide angle audio / video module

Cat. No. 3513 00

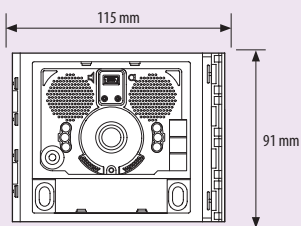

Technical data	
Power supply from SCS BUS	18-27 Vdc
Standby absorption (with backlighting LEDs off)	15 mA
Standby absorption (with backlighting LEDs on)	20 mA
Max. operating absorption	140 mA
Colour sensor	1/3"
Lens	f2.5 f31-8 mm
Resolution	330 TV lines
Illumination of the veiwing field	White LED
Brightness adjustment	Automatic
Interface	2 : 1
Mist prevention heating resistance	
Operating temperature	(-25)-(+70)°C
Protection Index (pushbutton panel assembled)	IP 54

#### 4 push button module / single column

Cat. No. 3520 00

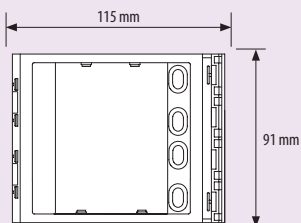

Technical data	
Power supply from SCS BUS	18-27 Vdc
Standby absorption (with backlighting LEDs off)	1 mA
Standby absorption (with backlighting LEDs on)	7 mA
Max. operating absorption	7 mA
Operating temperature	(-25)-(+70)°C
Protection Index (pushbutton panel assembled)	IP 54

### ■ Dimensions and technical data (continued)

#### 8 push button module / double column

Cat. No. 3521 00

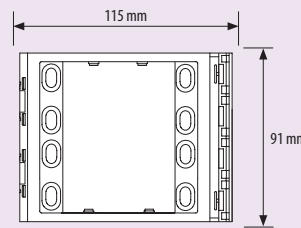

Technical data	
Power supply from SCS BUS	18-27 Vdc
Standby absorption (with backlighting LEDs off)	1 mA
Standby absorption (with backlighting LEDs on)	7 mA
Max. operating absorption	7 mA
Operating temperature	(-25)-(+70)°C
Protection Index (pushbutton panel assembled)	IP 54

#### Nameplate module

Cat. No. 3522 00

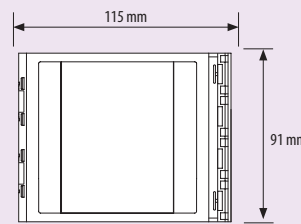

Technical data	
Power supply from SCS BUS	18-27 Vdc
Standby absorption (with backlighting LEDs off)	0 mA
Standby absorption (with backlighting LEDs on)	6 mA
Operating temperature	(-25)-(+70)°C
Protection Index (pushbutton panel assembled)	IP 54

#### Night / day and wide angle camera module

Cat. No. 3524 00

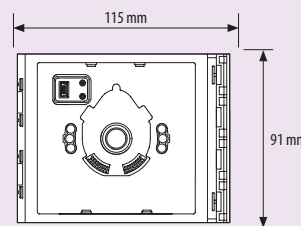

Technical data	
Power supply from SCS BUS	18-27 Vdc
Standby absorption	20 mA
Max. operating absorption	115 mA
Colour sensor	1/3"
Lens	f2.5 f31-8 mm
Resolution	330 TV lines
Illumination of the veiwing field	LED IR
Brightness adjustment	Automatic
Interface	2 : 1
H and D function with automatic IR filter removal	
Mist prevention heating resistance	
Operating temperature	(-25)-(+70)°C
Protection Index (pushbutton panel assembled)	IP 54

#### Graphic display module

Cat. No. 3525 00

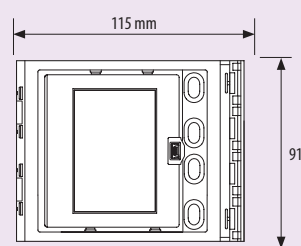

Technical data	
Power supply from SCS BUS	18-27 Vdc
Standby absorption	40 mA
Max. operating absorption	50 mA
Display type	Negative transfective
FSTN	
Disply resolution	160 x 240
Operating temperature	(-25)-(+70)°C
Protection Index (pushbutton panel assembled)	IP 54

#### Inductive loop and control speech synthesis module

Cat. No. 3527 00

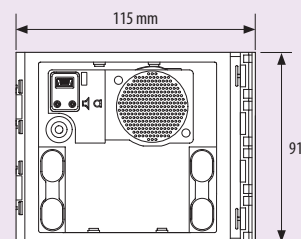

Technical data	
Power supply from SCS BUS	18-27 Vdc
Standby absorption	18 mA
Max. operating absorption	60 mA
Operating temperature	(-25)-(+70)°C
Protection Index (pushbutton panel assembled)	IP 54

## Bticino digital function modules for Sfera modular entrance panels (continued)

### ■ Dimensions and technical data (continued)

#### Keypad module

Cat. No. 3530 00

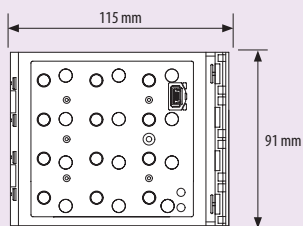

Technical data	
Power supply from SCS BUS	18-27 Vdc
Standby absorption (with backlighting LEDs off)	10 mA
Standby absorption (with backlighting LEDs on)	25 mA
Max. operating absorption	45 mA
Operating temperature	(-25)-(+70)°C
Protection Index (pushbutton panel assembled)	IP 54

#### Badge reader module

Cat. No. 3532 00

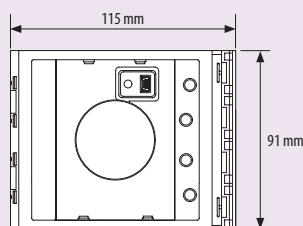

Technical data	
Power supply from SCS BUS	18-27 Vdc
Standby absorption (with backlighting LEDs off)	75 mA
Standby absorption (with backlighting LEDs on)	85 mA
Max. operating absorption	105 mA
Operating temperature	(-25)-(+70)°C
Protection Index (pushbutton panel assembled)	IP 54

#### Fingerprint reader module

Cat. No. 3533 00

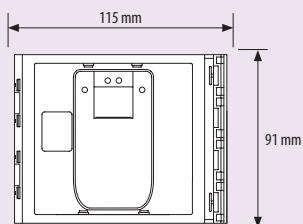

Technical data	
Power supply from SCS BUS	18-27 Vdc
Standby absorption	30 mA
Max. operating absorption	80 mA
Operating temperature	(-25)-(+70)°C
Protection Index (pushbutton panel assembled)	IP 54

## Bticino internal units and handsets multimedia and video

### ■ Dimensions and technical data

#### Multimedia touch screen (Arteor)

Cat. Nos. 573962/63

Technical data	
Power supply from SCS BUS	18-27 Vdc
Local power supply (1-2)	18-27 Vdc
Max. local absorption (1-2)	600 mA
Absorption from SCS BUS	50 mA
Operating temperature	5-40°C

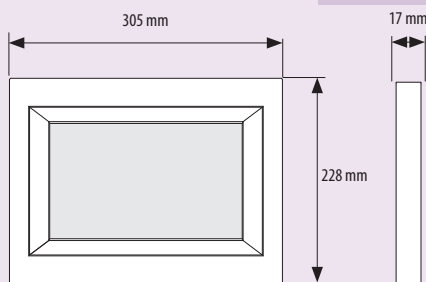

#### 8" multifunctional display screens (Axolute)

Cat. Nos. 3493 20/21

Technical data	
Power supply from SCS BUS	18-27 Vdc
Standby absorption	30 mA
Max. operating absorption	520 mA
Operating temperature	5-40°C

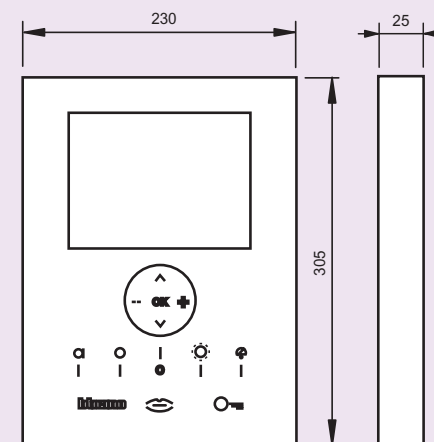

#### 2-5" multifunctional display screens

Cat. Nos. 5739 50/51

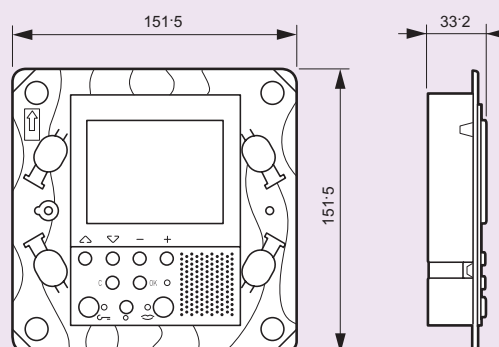

## Bticino internal units and handsets (continued)

video and audio

### ■ Dimensions and technical data (continued)

#### Video internal unit (Polyx)

Cat. No. 3441 82

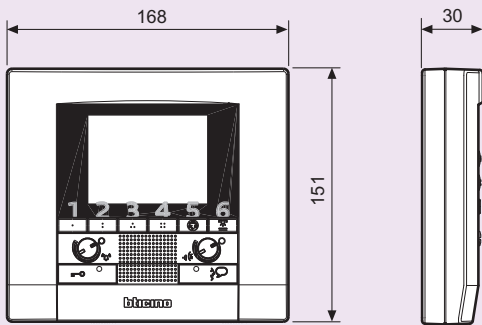

#### Video handsets (Swing)

Cat. Nos. 3448 24/32

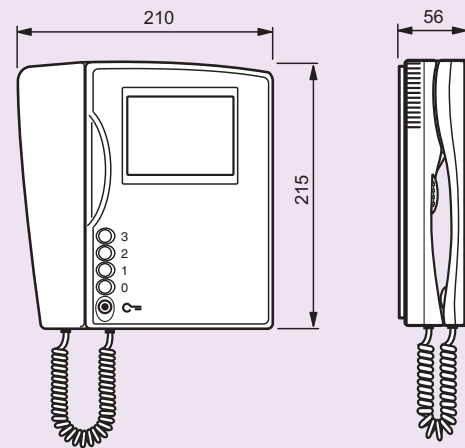

#### Audio internal units (Arteor)

Cat. Nos. 5740 11 and 5743 11

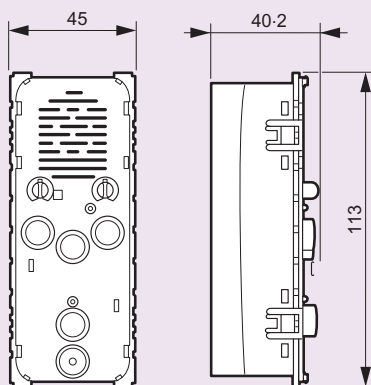

### ■ Dimensions and technical data (continued)

#### Audio internal unit (Polyx)

Cat. No. 3440 82

Technical data	
Power supply from SCS BUS	18-27 Vdc
Standby absorption	5 mA
Max. operating absorption	55 mA
Operating temperature	5-40°C

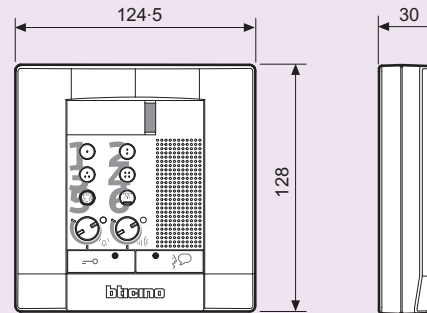

#### Audio handset (Swing)

Cat. No. 3447 04

Technical data	
Power supply from SCS BUS	18-27 Vdc
Standby absorption	5 mA
Max. operating absorption	35 mA
Operating temperature	5-40°C

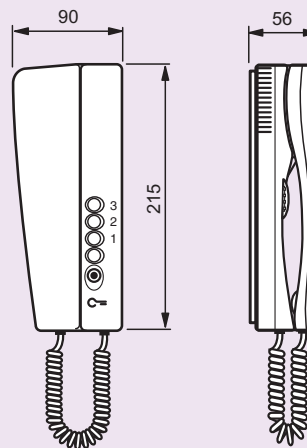

#### Audio handset (Sprint)

Cat. Nos. 3442 02/12

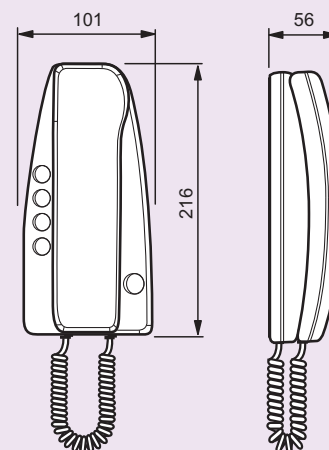

# MaxiRex and EconoRex

## analogue time switches

surface and panel mounting

### ■ Technical information

Type Cat. No.	MaxiRex T 0497 50	MaxiRex QT 0497 54	EconoRex MT 0499 83
Supply voltage	230 V~+10% -15%		
Frequency	50 Hz	50/60 Hz	50 Hz
Switching capacity :			
cos φ = 1	16 A		16 A
cos φ = 0.6	10 A		8 A
incand. lamp	1 000 W		1 000 W
Contact	1 c/o SPDT	1 c/o SPDT	1 c/o
Working reserve	None	100 hrs	None
Min. switching time	30 mins		15 mins
Interval	10 mins		15 mins
IP rating	IP 30		
Storage temp.	-10 °C to +60 °C		
Operating temp.	0 °C to +55 °C		

### ■ Dimensions (mm)

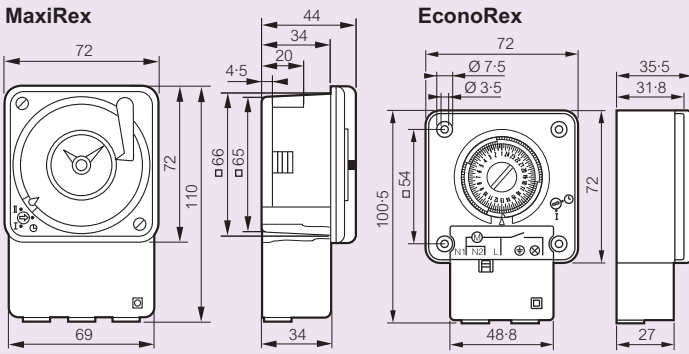

### ■ MaxiRex mounting

#### Wall mounting

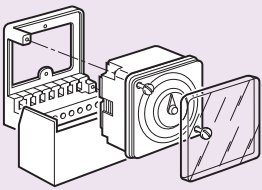

#### Panel mounting

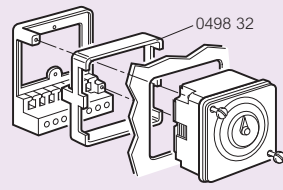

Panel mounting with support  
Cat. No. 0498 32  
to be ordered separately

#### DIN rail mounting

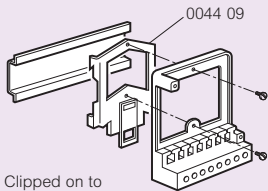

Clipped on to  
DIN rail EN 60715  
Adaptor to be ordered  
separately (Cat. No. 0044 09)

### Wiring diagrams

#### MaxiRex and EconoRex

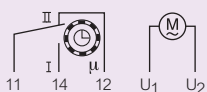

### ■ EconoRex mounting

#### Wall mounting

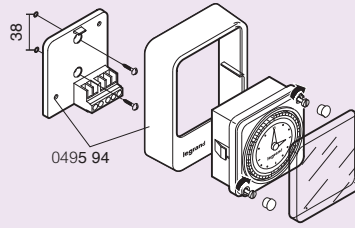

#### Panel mounting

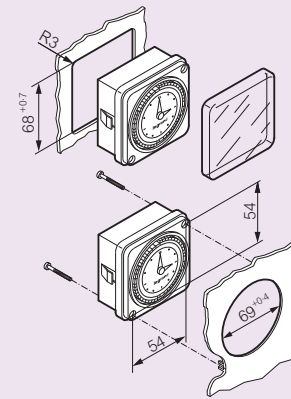

### ■ MicroRex D11

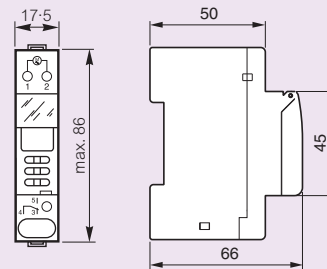

### Wiring diagram

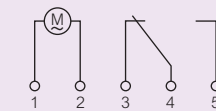



# chimes and bells



0416 50



0416 46



8200 21



0412 19



0420 25



For more information on modular bell transformers see p. 116 of the new Industrial and Power Protection catalogue

Pack	Cat. Nos.	Electromechanical chimes
1	White 0416 50	Tone level : 80 dB at 1 m Dimensions : 116 x 116 x 48 mm <b>8 / 12 V~ chime</b> Compatible with non-illuminated push button Cat. No. 0416 46 (see below) Use an 8 VA transformer Cat. No. 4130 91 or 0420 25 (see opposite)
1	0416 52	<b>230 V~ chime with transformer</b> 50/60 Hz - Class II with built-in 8 / 12 V~ transformer Compatible with non-illuminated push button Cat. No. 0416 46 (see below)

Pack	Cat. Nos.	Surface mounting bell pushes
5	White 0416 46	<b>24 V - 2 A</b> IP 30 - Class III <sup>1</sup> Horizontal or vertical installation Fixing screws not supplied Dimensions : 50 x 25 x 20 mm
20	8200 21	<b>12 V</b> Large push button Micro switch with a "click" feedback Quick cable connection from the front

Pack	Cat. Nos.	Bells with cover
1	White 0412 19	IP 20 - IK 10 Surface mounting with levelling facility Tone level : 80 dB at 1 m Consumption : 45 mA Dimensions : 135 x 88 x 48 mm <b>8 V~ 50/60 Hz<sup>1</sup> - Class III</b>
1	0412 43	<b>230 V~ 50/60 Hz - Class II</b> with built-in transformer Warning : take lamps out of bell pushes

Pack	Cat. Nos.	Safety isolating transformers
1	White 0420 25	Conform to BS 3535-1 and IS EN 60742 and IEC 61558-2-8 Surface mounting, double insulated $\square$ Dimensions : 92 x 56 x 42 mm <b>230 V~ primary</b> 8 / 12 V~ secondary at 1 A
1	0420 27	8 / 12 V~ secondary at 2 / 3 A

Pack	Cat. Nos.	Bell transformer								
1	4130 91	Conforms to IEC/EN 61558-2-8 Supplied with label holder Protected against overloads and short circuits Power to 8 V-12 V or 24 V access control devices such as bells and chimes Possibility for supply busbars to run through <b>230 V / 12 V - 8 V</b>								
		<table border="1"> <thead> <tr> <th>Secondary (V)</th> <th>Rating (A)</th> <th>Power (VA)</th> <th>Number of 17.5 mm modules</th> </tr> </thead> <tbody> <tr> <td>12 / 8 V~</td> <td>0.66/1 A</td> <td>8 VA</td> <td>2</td> </tr> </tbody> </table>	Secondary (V)	Rating (A)	Power (VA)	Number of 17.5 mm modules	12 / 8 V~	0.66/1 A	8 VA	2
Secondary (V)	Rating (A)	Power (VA)	Number of 17.5 mm modules							
12 / 8 V~	0.66/1 A	8 VA	2							

1 : Very low safety voltage



# Building automation systems

Radio/ZigBee®  
technology Arteor™

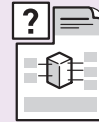

**P. 42**  
Introduction  
to Radio/Zigbee®  
technology

BUS/SCS  
technology  
Arteor™

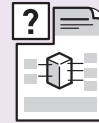

**P. 50**  
Introduction  
to BUS/SCS  
technology



**P. 57**  
Actuators,  
dimmers  
max. loads  
selection chart



**P. 63**  
Sound  
distribution  
installation

Home networks



**P. 68**  
Introduction to  
Home networks

## NEW IN 2012



**Arteor™ BUS / SCS**  
1.2" touch screen  
(p. 52)



**Arteor™ BUS / SCS**  
3.5" touch screen  
(p. 64)

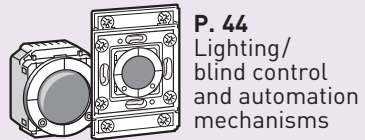

**P. 44**  
Lighting/  
blind control  
and automation  
mechanisms

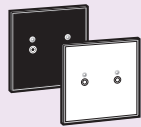

**P. 46**  
Touch  
plates

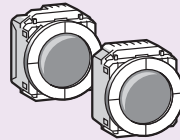

**P. 46**  
Other  
functions



**P. 49**  
Switches,  
dimmers  
max. loads  
selection chart

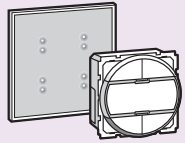

**P. 52**  
Lighting control  
and automation  
mechanisms

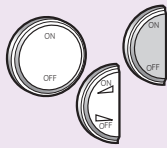

**P. 53**  
Key covers

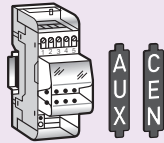

**P. 54**  
Actuators,  
BUS power  
supplies  
accessories



**P. 56**  
Lighting control  
and automation  
installation

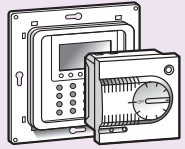

**P. 58**  
Temperature  
control

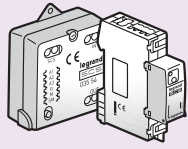

**P. 59** NEW  
Energy  
management



**P. 60**  
Temperature  
control  
installation

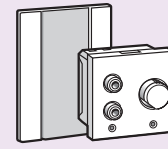

**P. 61**  
Sound  
distribution

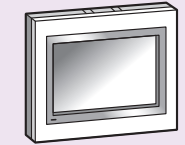

**P. 64** NEW  
Home  
management  
system

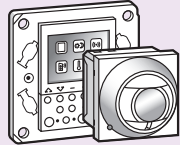

**P. 65**  
Door entry  
system

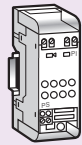

**P. 66**  
Accessories  
for video door  
entry systems

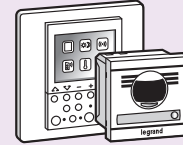

**P. 67**  
Video door  
entry system  
kits

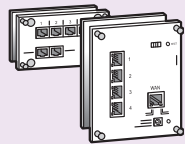

**P. 70**  
Home networks  
Arteor and Synergy  
structured wiring



**P. 72**  
Arteor and Synergy  
structured wiring -  
audio technical  
characteristics



## Energy management (p. 59)



# Arteor<sup>TM</sup> and ZigBee\* radio technology

setting the standard for wireless installations

Arteor's wireless range uses ZigBee - a widely recognised international radio communication standard - making it ideal for small, new installations and refurbishment projects. In addition, it can be used with the Arteor BUS system to increase the number of control points within an existing installation.

Operating at a frequency of 2.4 GHz, Arteor ZigBee wireless transmitters and receivers control lighting, roller blinds and technical detectors, and provide the added functionality of scenario control and bi-directional communication between devices.

**LIGHTING CONTROL**



**INDIVIDUAL RECEIVER:  
DIMMER SWITCH**  
(See p. 4)  
Indicates the light  
intensity via LEDs

**SCENARIO CONTROL**



**4 SCENARIO CONTROL**  
(See p. 5)  
For automation of  
lighting etc

**ROLLER BLIND CONTROL**



**INDIVIDUAL RECEIVER:  
ROLLER BLIND SWITCH**  
(See p. 4)  
Controls any type of electric  
roller blind

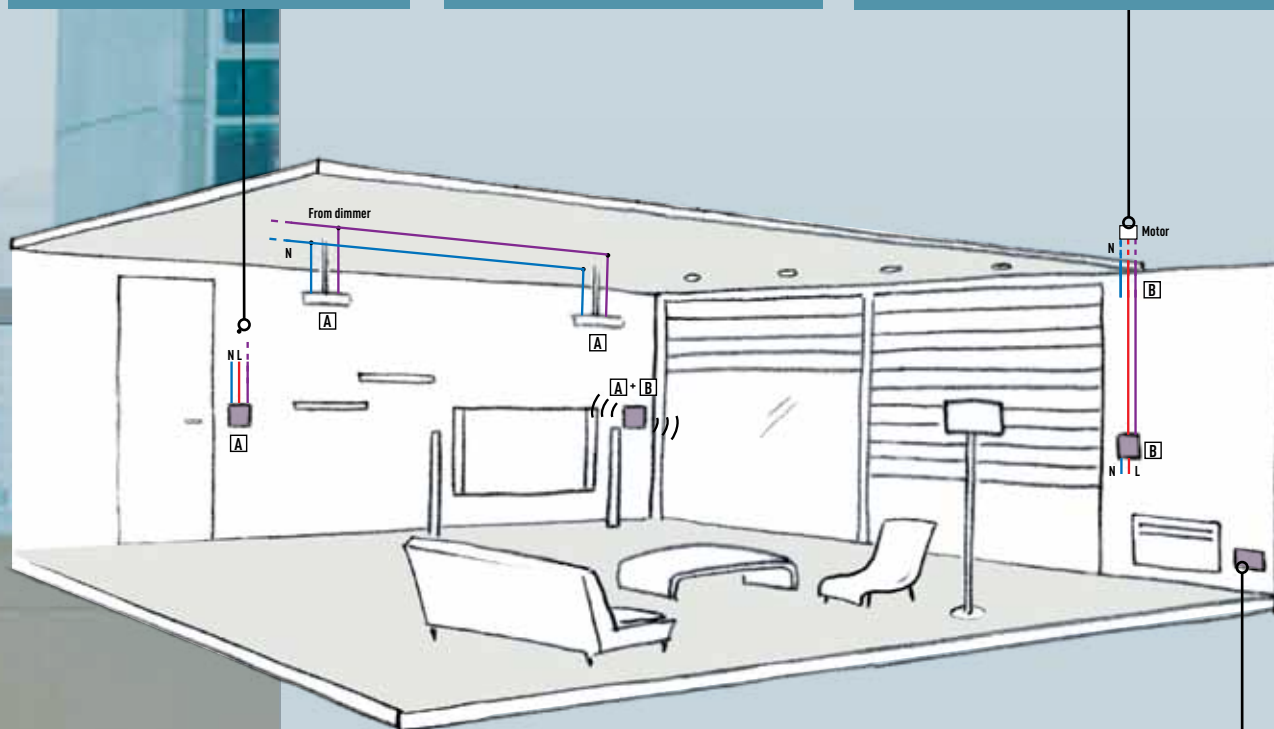

**TECHNICAL ALARM**



**TECHNICAL  
DETECTORS**  
(See p. 9)  
Indicates  
water or gas  
leaks

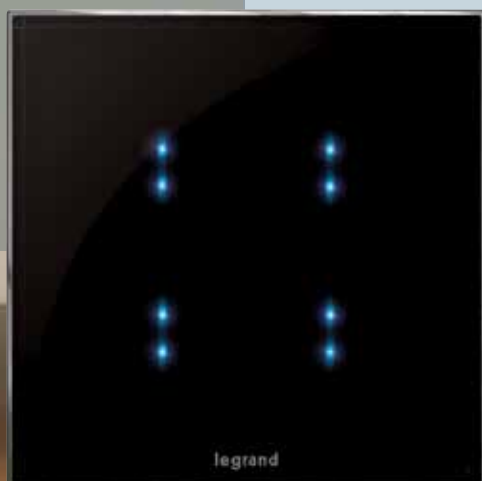

- A** Indicates lighting control
- B** Indicates roller blind control



# ARTEOR™

BUS/SCS technology  
unlocking functionality



Arteor's BUS/SCS building automation system makes it easy to create scenarios that incorporate multiple functions for large living areas and commercial environments... simultaneously controlling lighting, temperature, multimedia, video door entry and more.

### SIMPLE SOPHISTICATION

With just 2 dedicated wires, Arteor BUS/SCS technology is simple to install, yet its innovative design makes it sophisticated enough to meet the needs of complex installations. What's more, installations can be reconfigured and reprogrammed without the need for rewiring.

## DOOR ENTRY SYSTEMS



**AUDIO AND VIDEO DOOR ENTRY**  
(See p. 28)  
Access control and intercommunication with other units

## SCENARIO CONTROL



**SCENARIO CONTROL**  
(See p. 12)  
For the activation of up to 4 scenarios

## TEMPERATURE CONTROL



**CENTRAL UNIT FOR TEMPERATURE CONTROL**  
(See p. 19)  
Can manage up to 99 zones

## ROLLER BLIND CONTROL



**ROLLER BLIND CONTROL**  
(See p. 12)  
Controls any type of electric roller blind

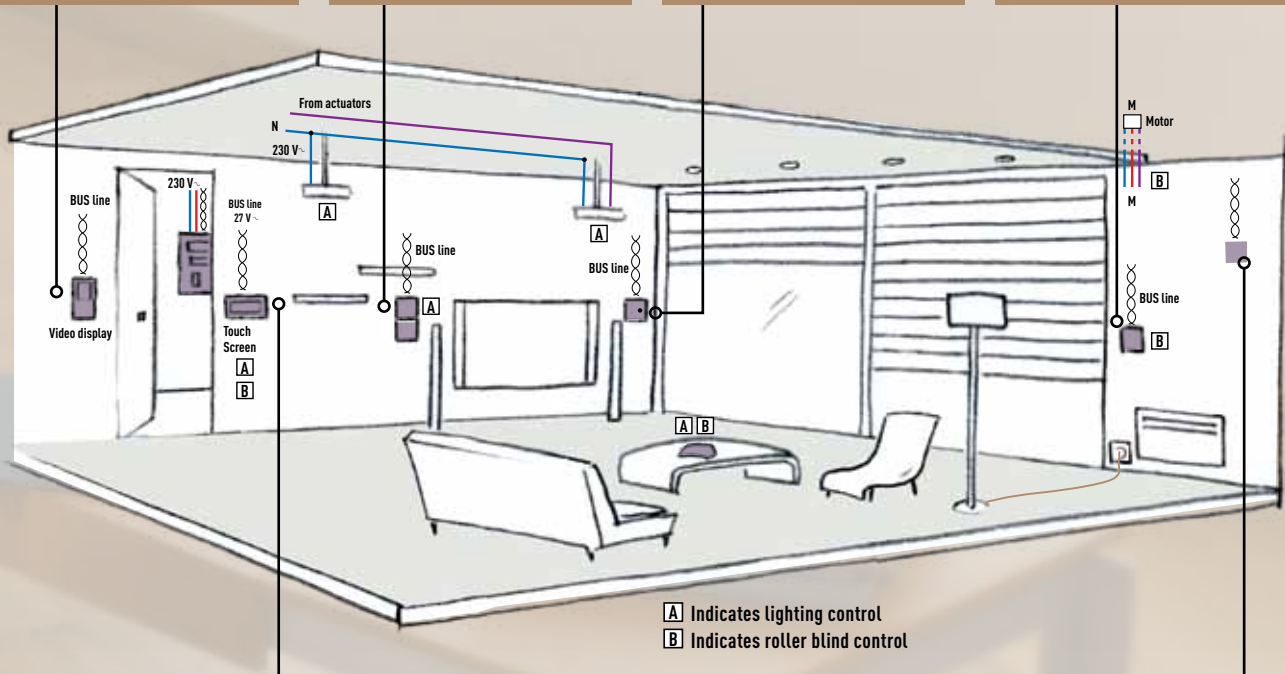

**A** Indicates lighting control  
**B** Indicates roller blind control

## HOME MANAGEMENT



**10" TOUCH SCREEN**  
(See p. 25)  
Complete control of the automation system, including:  
- door entry system  
- scenarios (multiple functions simultaneously)  
- lighting, temperature, roller blinds  
- multimedia distribution  
- energy consumption

## SOUND DISTRIBUTION



**AMPLIFIER**  
(See p. 22)  
Controls the volume of ceiling speakers in each room / zone



Choose the functions that meet the demands of your installation... then choose the finish that matches your interior design scheme.

For the full range of matching Arteor wiring accessories see p. 107

# Arteor™ Radio/ZigBee®

lighting and roller blind controllers/receivers

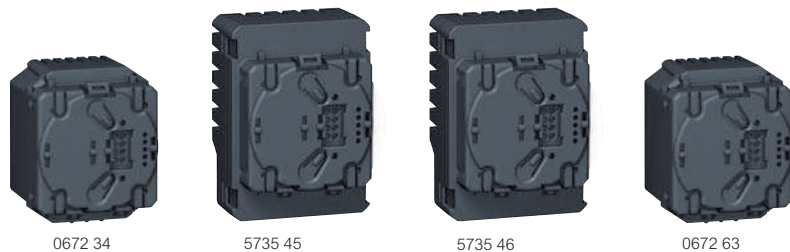

0672 34

5735 45

5735 46

0672 63

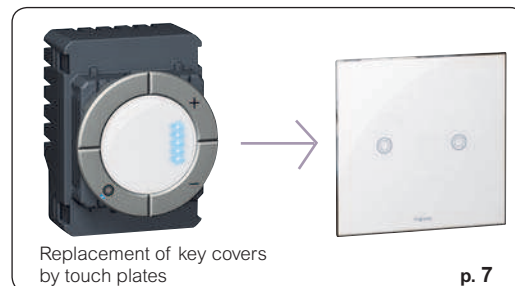

Replacement of key covers by touch plates

p. 7



Support frame and surround plate selection charts **p. 30-33**

Load selection charts **p. 10**

Technical information : [www.legrand.co.uk/arteor-building-automation](http://www.legrand.co.uk/arteor-building-automation) and follow the link to 'Arteor project and technical guide'

Receivers to be equipped with round or square key covers in white or black finish with magnesium buttons (p. 6),

2 module surround plates (p. 30-33) and 2 module support frames (p. 30-33)

Standard key covers can be replaced by touch plates (p. 7)

To be installed in flush mounting boxes min. depth 40 mm

Connect to the load and can be controlled by remote control transmitters, scenario switches, mobile control units and detectors (p. 5, 8, 9)

Pack	Cat.Nos	Lighting controllers/receivers (switches) 100/240 VA
1	0672 31	Each active button on the receivers is identified by LED (blue LED indicator status supplied) <b>Switch without neutral – 300 W - 1 circuit</b> 
1	5735 44	<b>NEW</b> <b>Switch without neutral – 2 x 300 W - 2 circuits</b> Supplied with support frame 
1	0672 33	<b>Switch with neutral – 2500 W - 1 circuit</b> 
1	0672 34	<b>Switch with neutral – 2 x 1000 W - 2 circuits</b> 
1	5735 45	<b>Switch with neutral – 3 x 1000 W - 3 circuits</b> 

Pack	Cat.Nos	Lighting controllers/receivers (dimmers) 100/240 VA
1	0672 37	Each active button on the receivers is identified by LED (with blue LED bargraph) <b>Leading/trailing edge dimmer without neutral – 300 W</b> 
1	5735 46	<b>Leading/trailing edge dimmer without neutral – 600 W</b> 
1	5735 49	<b>NEW</b> <b>Leading/trailing edge dimmer without neutral – 2 x 300 W</b> Supplied with support frame 
1	5735 47	<b>Universal dimmer with neutral – 400 W</b> 
1	5735 48	<b>0-10 V dimmers</b> 

1	0672 63	<b>Roller blind controllers/receivers – 100/240 VA</b> 
---	---------	------------------------------------------------------------

### Selecting Arteor components

Support frame + Mechanism + Touch plate  
OR  
Key cover + Surround plate



## Arteor™ Radio/ZigBee® lighting and roller blind transmitters



0672 35



Surround plate selection charts **p. 30-33**  
Replacement of key covers by touch plates **p. 7**  
Technical information :  
[www.legrand.co.uk/arteor-building-automation](http://www.legrand.co.uk/arteor-building-automation)  
and follow the link to 'Arteor project and technical guide'

Transmitters to be equipped with round or square key covers in white or black finish with magnesium buttons (p. 6), 2 module surround plates (p. 30-33) and multi-standard support frames (with removable fins) see Cat. No. 5735 51 (opposite)  
Standard key covers can be replaced by touch plates (p. 7)  
Surface mounting with direct fixing of support frame on wall  
Control one or more Radio/ZigBee® receivers  
No wiring needed. Supplied with batteries<sup>1</sup>

Pack	Cat.Nos	Lighting remote control transmitters
1	0672 35	<b>For 1 circuit switch controllers</b> 
1	0672 36	<b>For 2 circuit switch controllers</b> 
1	0672 39	<b>For dimmer controllers</b> 

Pack	Cat.Nos	Roller blind control transmitters
1	0672 64	<b>For roller blind controllers</b> 

## Arteor™ Radio/ZigBee® scenario controllers



5735 51



5738 70



0882 32



Surround plate selection charts **p. 30-33**  
Technical information :  
[www.legrand.co.uk/arteor-building-automation](http://www.legrand.co.uk/arteor-building-automation)  
and follow the link to 'Arteor project and technical guide'

Pack	Cat.Nos	Wall mounting scenario controllers
1	0672 40	<b>4-scenario controllers</b> To be equipped with round or square key covers in white or black finish with magnesium buttons (p. 6), 2 module surround plates (p. 30-33) and multi-standard support frames (with removable fins) see Cat. No. 5735 51 (below) Standard rocker plates and surround plates can be replaced by touch plates (p. 7) Surface mounting with direct fixing of support frame on wall No wiring needed Supplied with batteries <sup>1</sup> <b>4-scenario controllers</b> 4 push buttons to control 4 scenarios (1 scenario can control several functions: shutters, lighting...) 
1	5735 51	<b>Multi-standard support frame</b> For scenario controllers, light and roller blind transmitter Radio/ZigBee® 
1	5738 70	<b>Mobile scenario controllers</b> 1 scenario can control several functions: lighting level adjustment, roller blinds, general ON or OFF... <b>Pocket scenario controller</b> 4-scenario controller For Radio/ZigBee® installation Supplied with batteries <sup>1</sup> 
1	0882 32	<b>Radio/ZigBee® - IR remote control</b> 5-scenario controller Supplied with batteries <sup>1</sup> 

### Selecting Arteor components

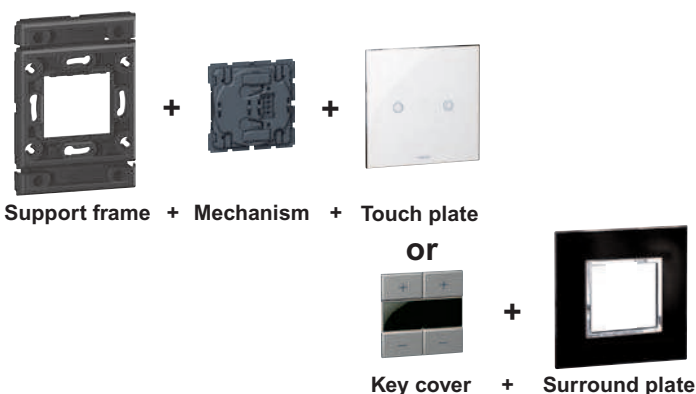

1 : Battery life 5 years

ZigBee®: Certified product Manufacturer Specific Profile  
1 : Battery life 5 years

# Arteor™ Radio ZigBee®

lighting control, automation and scenario key covers – selection chart



Technical information : [www.legrand.co.uk/arteor-building-automation](http://www.legrand.co.uk/arteor-building-automation) and follow the link to 'Arteor project and technical guide'

## ■ Selection chart for round and square key covers

Key covers are available in round or square versions, in white or black finish with magnesium buttons  
Use in conjunction with surround plates to complete your installation (p. 30-33)

Key cover description	ROUND VERSION			SQUARE VERSION		
		White ○	Black ●		White ○	Black ●
Lighting switch 1 circuit		5745 55	5745 56		5745 73	5745 74
Lighting switch 2 circuits		5745 57	5745 58		5745 75	5745 76
Lighting switch 3 circuits		5745 59	5745 60		5745 96	5745 97
Lighting dimmer with blue LED bargraph		5745 61	5745 62		-	-
Lighting dimmer without blue LED bargraph		5745 63	5745 64		5745 81	5745 82
Lighting dimmer 2 circuits with blue LED bargraph		5745 65	5745 66		5745 79	5745 80
Roller blind control		5745 67	5745 68		5745 83	5745 84
4 scenario controller		5745 69	5745 70		5745 77	5745 78
False key cover		5745 71	5745 72		5745 85	5745 86

# Arteor™ Radio/ZigBee®

## touch plates – selection chart



5737 51



5737 54



5737 64



5737 69



5737 91

Technical information : [www.legrand.co.uk/arteor-building-automation](http://www.legrand.co.uk/arteor-building-automation) and follow the link to 'Arteor project and technical guide'

### ■ Selection chart for touch plates

Touch plates are available in white or black and can be used instead of key covers and surround plates

Function	Touch plates			Associate mechanisms	
		Colour	BS fixing centres	Control mechanism (receiver)	Remote control transmitter
Touch control switch 1 circuit		White	5737 50	0672 31	0672 35 0672 39
		Black	5737 51		
Touch control switch 2 circuits		White	5737 54	0672 34	0672 36
		Black	5737 55		
Touch control switch 3 circuits		White	5737 64	5735 45	
		Black	5737 65		
Touch control dimmer 1 circuit		White	5737 58	0672 37 5735 46 5735 47	0672 39
		Black	5737 59		
Touch control roller blinds switch 1 circuit		White	5737 68	0672 63	0672 64
		Black	5737 69		
4-scenario touch control		White	5737 90	0672 40	
		Black	5737 91		

# Arteor™ Radio/ZigBee®

## other functions





0883 05



5738 62



Support frames and surround plates selection charts **p. 30-33**  
 Loads selection chart **p. 10**  
 Technical information : [www.legrand.co.uk/arteor-building-automation](http://www.legrand.co.uk/arteor-building-automation) and follow the link to 'Arteor project and technical guide'



Pack	Cat. Nos.	Water heater switches – receivers
1	5735 50	<p>Can be activated by any other radio device            Receivers to be equipped with round or square key covers in white or black finish with magnesium buttons (p. 6), 2 module surround plates (p. 30-33) and 2 module support frames (p. 30-33)            To be installed in flush mounting boxes – min. depth 40 mm</p> 

Pack	Cat. Nos.	BUS/SCS-Radio/ZigBee® Arteor gateways
1	0672 50	<p>To be equipped with round or square key covers in white or black finish with magnesium buttons (p. 6) and 2 module surround plates (p. 30-33)            To be installed in flush mounting boxes – min. depth 40 mm            Used to link a BUS/SCS installation and an additional Radio/ZigBee® installation            Used to control up to 32 transmitters</p> 

Pack	Cat. Nos.	Transmitter with auxiliary inputs
1	0883 31	<p>Can be used to initiate ON/OFF on closing or opening of a volt-free contact            For controlling a Radio/ZigBee® installation using commercially available detectors (eg light sensitive switch, moisture sensor)            Fits behind a traditional switch, without damage to the walls, to control a Radio/ZigBee® switch</p>

Pack	Cat. Nos.	Radio/ZigBee® micromodule switch
1	0883 05	<p>1 output – 300 W            Enables control points to be added to improve an existing installation without damage to the walls            Controls energy-saving, LED, halogen and incandescent bulbs            Suitable for fitting on DCL (lighting appliance) covers. Its receiver function is used to execute commands received from scenario switches, centralised control units, detectors            Phase/neutral power supply</p> 

Pack	Cat. Nos.	Transmitter/receiver mobile sockets
1	0883 20	<p>Connect directly to an existing 2P + E socket to switch the light connected to the socket            Its receiver function is used to execute commands received from scenario switches, centralised control units, detectors, etc</p> <p><b>Radio/ZigBee® mobile dimmer switch-sockets</b>            500 VA            2 lighting levels® (factory-preset and modifiable by the user)</p>  <p>British standard</p>
1	0883 23	<p><b>Radio/ZigBee® switch-sockets</b>            10 A            British standard</p> 

Pack	Cat. Nos.	Transmitter/receiver control units for false ceiling – 100-240 VA
1	5738 62	<p>Its receiver function is used to execute, on its circuits, on/off commands received from centralised control units, scenario switches, mobile control units and detectors</p> <p><b>Universal switch – phase/neutral</b>            1 output – 2 500 W</p> 
1	5738 64	<p><b>Dimmer for all loads (excluding fluorescent and LEDs) – without neutral</b>            1 output – 600 W</p> 
1	5738 66	<p><b>Dimmer for 1-10 V ballast – phase/neutral</b>            1 output – 500 VA</p> 

ZigBee®: Certified product Manufacturer Specific Profile

# Arteor™ Radio/ZigBee® other functions (continued)



0883 27



Plexo flush and surface mounting boxes, see Wiring devices catalogue



0882 91



0672 33





Support frames and surround plates selection charts **p. 30-33**

Loads selection chart **p. 10**

Technical information : [www.legrand.co.uk/arteor-building-automation](http://www.legrand.co.uk/arteor-building-automation) and follow the link to 'Arteor project and technical guide'

Pack	Cat. Nos.	<b>Weatherproof (Plexo) radio transmitter/receiver switch</b>
1	0695 03	 <p>2500 W Its transmitter function allows it to control another lighting Radio/Zigbee® receiver switch Its receiver function is used to execute commands received from centralised control units, scenario switches, mobile control units and detectors 3 wire installation in box depth 40 mm min.</p>

Pack	Cat. Nos.	<b>Weatherproof radio individual blind switch</b>
1	0883 27	 <p>Controls motors (4 wire) on 230 V electric blinds for lowering/raising/stopping the blind Installed in the loft or in the blind head rail during modernisation of an existing blind without damage to the walls Must be used together with a centralised switch Cat. No. 0672 64 (p. 5) Must remain accessible for any programming necessary Maximum loads supported in 230 VA : 1 x 500 VA</p>

Pack	Cat. Nos.	<b>Weatherproof radio transmitter/receiver multifunction switches - 230 VA</b>
1	5738 58	 <p>Switches for controlling 1 or 2 circuits connected to its terminals according to 3 different operating modes : time-lag switch, switch, remote control switch Its receiver function is used to execute, on its circuits, on/off commands received from individual control units, centralised control units, scenario switches, mobile control units and detectors Phase/neutral power supply Weatherproof multifunction switch 2 500 W</p>
1	5738 60	 <p>Weatherproof multifunction 2 gang switch 2 x 2 500 W</p>

Pack	Cat. Nos.	<b>Indoor motion detector</b>
1	0882 91	 <p>Used to control a scenario by detecting movement, especially switching on lights automatically to create an illuminated pathway (from the bedroom to the WC for example) Infrared detection (range 11 m, time delay between 3 and 60 min, detection angle : 85°, light level threshold between 20 and 1 000 lux) Set by mobile configurators Cat. Nos. 0882 30/35 (see Wiring devices catalogue) Supplied with fixing base Detection at night only or night and day Wall mount at desired location 2 AA batteries</p>

Pack	Cat. Nos.	<b>Indoor temperature sensor</b>
1	0883 30	<p>IP 21 For indoor use only Setting : 2 temperature thresholds Temperature ranges : from -10°C to +40°C Can be used to initiate 2 scenarios when the temperature is higher than the high threshold or lower than the low threshold</p>

Pack	Cat. Nos.	<b>Technical alarms</b>
1	0672 33	<p>Equipped with round cover plates and magnesium circle for control To be equipped with 2 module surround plates and support frames (p. 30-33) To be installed in flush mounting boxes min. depth 40 mm</p> <p><b>NEW</b></p> <p><b>Actuators 100-240 V~ - 10 A</b> Used to close the valve from where gas/water is supplied to the installation Use transformers Cat. Nos. 5740 35 and 5740 85 (see Wiring devices catalogue) and detectors</p>
1	0675 25	<p><b>NEW</b></p> <p><b>Transceivers</b></p>

## ■ Switches and dimmers – maximum loads at 230 V

For values at 110 V, please halve values

		Universal								
		Leading edge		Trailing edge						
Cat.Nos.		Incandescent lamp	Halogen lamp	ELV halogen with ferromagnetic transformer	ELV halogen with electronic transformer	Fluorescent tube	Compact fluorescent lamp	LED	Fluorescent lamps with 0-10 V ballast	Reducer motor for shutter
SWITCHES	0672 31	300 W	300 W	300 VA	300 VA					
	5735 44	2 x 300 W	2 x 300 W	2 x 300 VA	2 x 300 VA					
	0672 33	2500 W	2500 W	2500 VA	2500 VA	1250 VA	1250 VA	1250 VA		
	0672 34	2 x 1000 W	2 x 1000 W	2 x 1000 VA	2 x 1000 VA	2 x 500 VA	2 x 500 VA	2 x 500 VA		
	5735 45	3 x 1000 W	3 x 1000 W	3 x 1000 VA	3 x 1000 VA	3 x 500 VA	3 x 500 VA	3 x 500 VA		
	0672 63									500 VA
	0883 27									500 VA
	5738 62	2500 W	2500 W	2500 VA	2500 VA	1250 VA	1250 VA	1250 VA		
	5738 58	2500 W	2500 W	2500 VA	2500 VA	1250 VA	1250 VA	1250 VA	yes	
	5738 60	2 x 2500 W	2 x 2500 W	2 x 2500 VA	2 x 2500 VA	2 x 1250 VA	2 x 1250 VA	2 x 1250 VA	yes	
	0883 05	300 W	300 W	300 VA	300 VA	300 VA	300 VA	300 VA	-	
	0883 23	1200 W	1200 W	1200 VA	1200 VA					
DIMMERS	0672 37	300 W	300 W	300 VA	300 VA					
	5735 49	2 x 300 W	2 x 300 W	2 x 300 VA	2 x 300 VA					
	5735 46	600 W	600 W	450 VA	600 VA					
	5735 47	400 W	400 W	400 VA	400 VA		160 VA	160 VA		
	5735 48								1000 VA	
	5738 66								1000 VA	
	5738 64	600 W	600 W	450 VA	600 VA					
	0883 20/22	60 W/500 W	60 W/500 W	60 VA/500 VA	60 VA/500 VA					

# Arteor™ BUS/SCS

lighting control and automation control mechanisms



0675 52



5739 04



5739 05









Key covers for micropush control mechanisms p. 13



Technical characteristics p. 17-18

Support frames and surround plates selection charts p. 30-33

Technical information : [www.legrand.co.uk/arteor-building-automation](http://www.legrand.co.uk/arteor-building-automation) and follow the link to 'Arteor project and technical guide'

Pack	Cat. Nos.	Basic control mechanisms	Pack	Cat. Nos.	Multi-functions control mechanisms
1	0675 52	<p>To be installed in flush mounting boxes</p> <p><b>Micropush control mechanisms</b></p> <p>To be equipped with round or square key covers in white or black finish with magnesium buttons (p. 13) and 2 module surround plates (p. 30-33) or touch plates (below)</p> <p> 2 module mechanism Control for the activation of 1 actuator for single or double loads, or 2 actuators for single load, or independent double loads for lighting and shutters</p>	1	0675 53	<p><b>Micropush control mechanisms</b></p> <p>To be equipped with round or square key covers in white or black finish with magnesium buttons (p. 13) and 2 module surround plates (p. 30-33) or touch plates (below)</p> <p> 2 module mechanism Control for the activation of 4 scenarios, soft-start and soft-stop of dimmers, sound distribution functions and activation of devices installed on different BUS branches</p>
1	0675 54	<p> 3 module mechanism Control for the activation of 3 actuators for single or double loads, or 2 actuators for single load or independent double loads</p>	1	5739 04   5739 05	<p><b>Touch plates</b></p> <p>Control for the activation of 4 scenarios, soft-start and soft-stop of dimmers, sound distribution functions</p> <p> 2 module mechanisms For use with Cat. No. 0675 53 (above)</p>
1	White 5739 08   Black 5739 09	<p><b>Touch plates</b></p> <p> 2 module mechanisms For use with Cat. No. 0675 52 (above)</p>			
1	5739 12   5739 13	<p> 3 module mechanisms For use with Cat. No. 0675 54 (above) To be used with frame Cat. No. 5760 40 + back box Cat. No. 0800 49 - dry partition or Cat. No. 0801 49 - concrete</p>	1	0675 56	<p><b>Flush mounting controller with built-in control</b></p> <p> For controlling two lighting circuits or a blind motor Slat orientation control 2 outputs - 2 A 230 V power supply</p> <p>To be installed in flush mounting boxes To be equipped with key covers (p. 13), support frames and surround plates (p. 30-33)</p>

**Scenario controllers with specific marking for hotels** (see p. 29)

# Arteor™ BUS/SCS

lighting control and automation control mechanisms (continued)



F401



Key covers for micropush control mechanisms p. 13



5739 02



5 737 16



5739 00



0882 32



5739 03 (for example scenario IN / OUT / DINNER / RELAX)



5739 01



Technical characteristics p. 17-18

Support frames and surround plates selection charts p. 30-33

Technical information : [www.legrand.co.uk/arteor-building-automation](http://www.legrand.co.uk/arteor-building-automation) and follow the link to 'Arteor project and technical guide'

Pack	Cat. Nos.	Advanced rolling shutter management devices
1	F401	Relay interlocking or pulse based motor drive. Position status return : closed, open, intermediate position. Drive following different orders : up, down, or opening % <b>2-relay controller for the driving of a motor</b> Maximum motor power : 500 W, 230 Vac Logic relay interlocking 2 DIN modules
1	<b>NEW</b> 0675 57	<b>Controller with integrated control for the driving of a motor</b> To be fitted with : - STOP key cover, Cat. Nos. 5745 45/46/47/48 - rolling shutter key cover Cat. Nos. 5745 15/16 and 5744 92/93 (p. 13) - Arteor surround plates (p. 30-33) - back box Maximum motor power : 500 W, 230 Vac Logic relay interlocking Stop, up, down function Possibility of blade angle adjustment Recall of a previously saved opening/closing position Recording of the opening/closing position on the control using self-learning procedure
1	<b>NEW</b> 0675 58	<b>Specific advanced motor management control</b> To be fitted with : - STOP key cover, Cat. Nos. 5745 45/46/47/48 - rolling shutter key cover Cat. Nos. 5745 15/16 and 5744 92/93 (p. 13) - Arteor surround plates (p. 30-33) - back box Point-point, room, group, and general control of the motor controlled rolling shutters, to be used in conjunction with actuators Cat. Nos. F401 or 0675 57 (above) Stop, up, down function Possibility of blade angle adjustment Recall of a previously saved opening/closing position Recording of the opening/closing position on the control using self-learning procedure

**Scenario controllers with specific marking for hotels** (see p. 29)

Pack	Cat. Nos.	Scenario controllers
1	5739 02	White Magnesium <b>NEW</b> 5745 03 5745 04
1	5745 03	
1	<b>NEW</b> 0675 92	<b>8 push button controllers</b> For lighting, automation, sound diffusion and scenario functions A5 sheets for the customisation of the symbols of Cat. No. 0675 92
1	5737 16	<b>Touch screens</b> Equipped with white or magnesium surround, to be equipped with square surround plates (p. 30-33) 1.2" OLED touch screen for management of max. 4 functions sound system, temperature control, 4 scenarios, energy management 2 module plates
1	5737 17	
1	5739 00	<b>IR receivers</b> With white or magnesium surround To be equipped with square surround plates (p. 30-33) To be associated with remote control Cat. No. 0882 32 (see below) Can receive up to 16 commands
1	5739 01	
1	0882 32	<b>Mobile scenario controller</b> <b>Advanced IR remote controller</b> 5 push buttons to control 5 scenarios (1 scenario can control several functions : shutters, lighting...) To be used in association with IR receiver Cat. Nos. 5739 00/01 (see above)



# Arteor™ BUS/SCS

lighting control and automation key covers

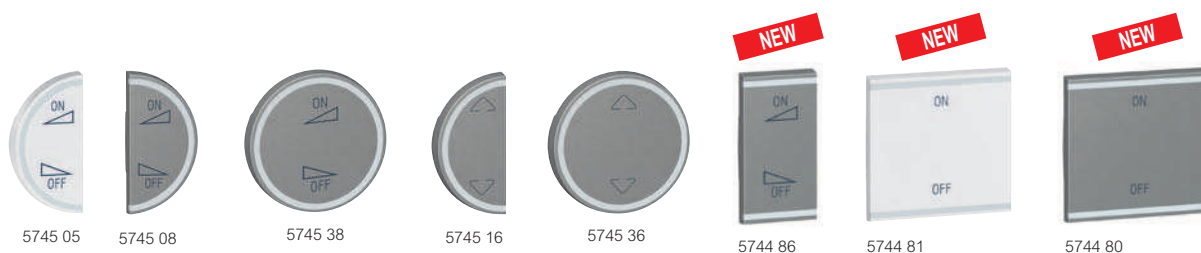

Technical information : [www.legrand.co.uk/arteor-building-automation](http://www.legrand.co.uk/arteor-building-automation) and follow the link to 'Arteor project and technical guide'

## ■ Selection chart for round or square key covers

Key covers are available in round or square versions, in white or black finish with magnesium buttons  
Use in conjunction with surround plates to complete your installation (p. 30-33)

key cover description	Modules	ROUND VERSION		SQUARE VERSION			
			White	Magnesium		White	Magnesium
Regulation symbol left-hand side mounting	1		5745 05	5745 06		5744 87	5744 86
Regulation symbol right-hand side mounting	1		5745 07	5745 08			
Regulation symbol	2		5745 37	5745 38		5744 89	5744 88
Up/Down symbol any side mounting	1		5745 15	5745 16		5744 93	5744 92
Up/Down symbol	2		5745 35	5745 36		5744 95	5744 94
GEN marking	2		5745 39	5745 40		5744 73	5744 72
ON/OFF marking	2		5745 33	5745 34		5744 81	5744 80
Sound source selection right-hand mounting	1		5745 11	5745 12		5744 91	5744 90
Shutter STOP marking any side mounting	1		5745 45	5745 46		5745 47	5745 48
Without marking any side mounting	1		5745 09	5745 10		5744 65	5744 64
Without marking	2		5745 13	5745 14		5744 67	5744 66

# Arteor™ BUS/SCS

lighting control and automation

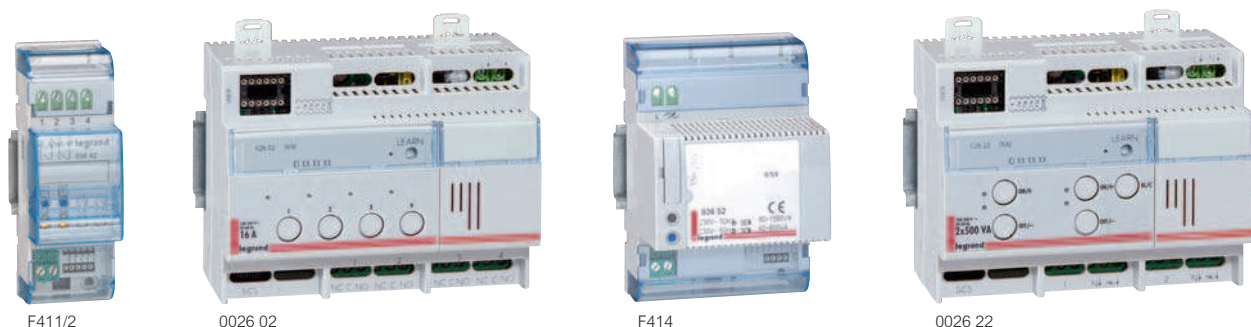

F411/2

0026 02

F414

0026 22

Technical characteristics **p. 17-18**  
 Support frames and plates selection charts **p. 30-33**  
 Technical information : [www.legrand.co.uk/arteor-building-automation](http://www.legrand.co.uk/arteor-building-automation) and follow the link to 'Arteor project and technical guide'

Pack	Cat. Nos.	DIN rail actuators 100/240 V~ - 50/60 Hz
1	F411/1N	N/O contact To be associated to loads and control mechanisms (p. 11-12) 1 output relay for controlling 1 circuit Maximum load : 16 A resistive load 2 DIN modules 17.5 mm Replaces Cat. No. 0038 41
1	F411/2	2 output relay for controlling 2 circuits Maximum load per circuit : 6 A resistive load or incandescent lamps 1 x 500 VA for roller blinds with end stops 2 DIN modules 17.5 mm. Replaces Cat. No. 0038 42
1	F411/4	4 output relay for controlling 4 circuits Maximum load per circuit : 6 A resistive load 2 DIN modules 17.5 mm Replaces Cat. No. 0038 44
1	0026 02	Relay with 4 x 16 A outputs 6 DIN modules 17.5 mm

Pack	Cat. Nos.	DIN controllers for dimming
1	F414	For use in conjunction with loads and control mechanisms (p. 11-12) for dimming control <b>For incandescent, halogen and ferromagnetic loads</b> Load : 60 – 1000 W / 230 VA - 50 Hz 4 DIN modules 17.5 mm. Replaces Cat. No. 0036 52 <b>For electronic transformers loads</b> 1 output Load : 0.25 to 1.7 A / 230 VA - 50 Hz 4 DIN modules 17.5 mm. Replaces Cat. No. 0036 53
1	F415	<b>For dimmer LEDs, compact fluorescent lamps CFL, energy saving halogen lamps and electronic transformers</b> 1 output – 300 VA maximum 230 Va.c. – 150 VA maximum 127 Vd.c. 4 DIN modules 17.5 mm
1	F413N	<b>For 1-10 V ballasts</b> Load : 500 VA maximum 2 DIN modules 17.5 mm. Replaces Cat. No. 0036 56
1	0026 11	1 output – 1000 VA maximum 6 DIN modules 17.5 mm
1	0026 31	<b>For DALI protocol</b> Enables communication between the BUS/SCS installation and the lighting appliances controlled by DALI protocol 6 DIN modules 17.5 mm
1	0026 21	<b>For incandescent, halogen 230 V, ELV halogen with electronic or ferromagnetic transformer</b> 6 DIN modules 17.5 mm Automatic recognition of the load
1	0026 22	1 output – 1000 W maximum 2 outputs – 400 W maximum per output

**NEW**

Pack	Cat. Nos.	RJ adaptor
10	0488 72	For connecting Cat. Nos. 0026 02/21/22/11 to the BUS

Pack	Cat. Nos.	BUS power supplies
1	E46ADCN	<b>27 V= - 1.2 A</b> Input voltage : 230 V~ output voltage 27 V= Maximum consumption : 300 mA Maximum current supplied : 1.2 A 8 DIN modules 17.5 mm Replaces Cat. No. 0035 60

Pack	Cat. Nos.	Power supplies
1	0634 42	<b>27 V= - 0.6 A</b> 220-240 V – 50/60 Hz Output 1-2 27 V= 600 mA 2 DIN modules 17.5 mm

Pack	Cat. Nos.	Contact interfaces
1	F428	Allow the connection between traditional wiring accessories such as switches, time delay switches or external sensors and BUS installation to control 2 actuators for single function or 1 actuator for double functions 2 independent contacts 2 DIN modules 17.5 mm Replaces Cat. No. 0035 53
1	3477	Basic modularity To be installed in flush mounting box Replaces Cat. No. 5739 96
1	F401	<b>2-relay controller for the driving of a motor</b> Maximum motor power : 500 W, 230 Vac Logic relay interlocking 2 DIN modules

**For Plexo<sup>3</sup> enclosures**  
(visit [www.legrand.co.uk](http://www.legrand.co.uk))

# Arteor™ BUS/SCS

accessories for automation



F425



F420



F422



3501/AUX



3501/CEN



3501K/1



Full technical guide available to download at [www.legrand.co.uk](http://www.legrand.co.uk)



Technical characteristics **p. 17-18**

Support frames and plates selection charts **p. 30-33**

Technical information : [www.legrand.co.uk/arteor-building-automation](http://www.legrand.co.uk/arteor-building-automation) and follow the link to 'Arteor project and technical guide'

Pack	Cat. Nos.	Additional DIN devices
1	F425	<b>Memory module for actuators</b> Restores the last state of an actuator in case of a power failure 2 DIN modules 17.5 mm Replaces Cat. No. 0035 52
1	F420	<b>Scenario module</b> Allows creation of scenarios by linking different functions Up to 16 scenarios 2 DIN modules 17.5 mm Replaces Cat. No. 0035 51
1	F422	<b>SCS-SCS gateway (extension)</b> Allows the extension of the installation or the integration between different functions Suitable for larger installations 2 DIN modules 17.5 mm Replaces Cat. No. 0035 62
<b>SCS cables</b>		
1	L4669	2 wire cable for BUS system Conform to IEC 45-5 and IEC 20-20 Length 100 m Replaces Cat. No. 0492 31
1	L4669/500	Length 500 m Replaces Cat. No. 0492 32
1	L4669KM1	Length 1 000 m. Supplied on wooden reels Replaces Cat. No. 0492 32
<b>Virtual configuration software</b>		
1	3504	<b>Virtual configuration software</b> Used to configure mechanisms and controllers in the installation for applications such as lighting, shutters and temperature control Comprising 1 CD with software for PC
<b>Additional devices</b>		
1	3559	<b>USB cable</b> Programming cable
10	3515	<b>BUS spare clamp</b> Used to connect the various system components (controls, dimmers, etc) to the BUS line

Pack	Cat. Nos.	Plug-in jumpers for all devices
Used to associate an address with the different system components		
<b>Individual plug-in jumpers</b>		
		Old Cat. No.
10	3501/0	0 0492 00
10	3501/1	1 0492 01
10	3501/2	2 0492 02
10	3501/3	3 0492 03
10	3501/4	4 0492 04
10	3501/5	5 0492 05
10	3501/6	6 0492 06
10	3501/7	7 0492 07
10	3501/8	8 0492 08
10	3501/9	9 0492 09
5	3501/GEN	GEN 0492 10
5	3501/GR	GR 0492 11
5	3501/AMB	AMB 0492 12
5	3501/AUX	AUX 0492 13
5	3501/ON	ON 0492 14
5	3501/OFF	OFF 0492 15
5	3501/O/I	O/I 0492 16
5	3501/PUL	PUL 0492 17
5	3501/SLA	SLA 0492 18
5	3501/CEN	CEN 0492 19
5	3501/T	↑↓ 0492 20
5	3501/TM	↑↓M 0492 21
<b>Plug-in jumper kits</b>		
1	3501K/1	Kit with : AUX, GEN, GR, AMB, ON, OFF, O/I, PUL, SLA, CEN, ↑↓, ↑↓M (10 pieces of each figure)
1	3501K	Old Cat. No. 0261 45 Kit with "0 to 9" jumpers (10 pieces of each figure)
<b>Plier</b>		
1	3502	Plier for plug-in in jumpers

**For Plexo<sup>3</sup> enclosures**  
(visit [www.legrand.co.uk](http://www.legrand.co.uk))

# Arteor™ BUS/SCS

accessories for automation



0488 23  
(directional head)

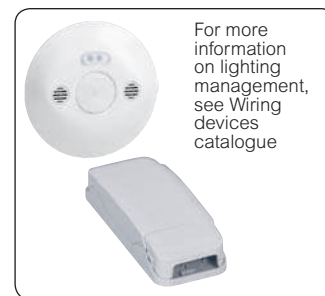

Technical information : [www.legrand.co.uk/arteor-building-automation](http://www.legrand.co.uk/arteor-building-automation) and follow the link to 'Arteor project and technical guide'

Pack	Cat.Nos	180° corner sensors
		Supplied with fixing base Connect to 2 circuit controller Cat.No. 0488 50 (see Wiring devices catalogue) by cord or RJ 45 cable or BUS/SCS cable fitted with RJ 45 connector Cat.No. 0488 72 (p. 14)
1	0488 24	<b>180° corner sensor – detection field 45 m<sup>2</sup> – for small offices</b> PIR – Maximum range 8 m – IP 42 Optimum distance between 2 sensors : 6 m Consumption 0.2 W on standby RJ 45 connection All loads 10 A – 240 V
1	0488 23	<b>180° corner sensor – detection field 90 m<sup>2</sup> – for conference rooms and large offices</b> Dual-tech – Maximum range 11 m – IP 42 With directional head Optimum distance between 2 sensors : 10 m Consumption 0.2 W on standby RJ 45 connection All loads 10 A – 240 V

Pack	Cat. Nos.	180° switch sensors
		Detection field 15 m <sup>2</sup>
		<b>Presence sensors</b> PIR -Maximum range 10 m – IP 41 ○ White ● Magnesium
1	5740 46	
1	5740 96	
		<b>Absence sensors</b> Dual-tech – Maximum range 10 m – IP 41 ○ White ● Magnesium
1	5740 48	
1	5740 98	

# Arteor™ BUS/SCS

lighting control and automation

## ■ System principle

The lighting control system allows the management of different functions in a simultaneous and integrated way. All the components of the lighting control system are interconnected via an electronic circuit that can be programmed : the BUS. The information is exchanged through the 2 wire BUS cable at low voltage (27 V= )

There are two types of devices in the system :

- the controls units, which are connected only to the BUS cable and
- the actuators, connected both to the BUS cable and to the 230V~ power line for managing the connected load

When the lighting control system devices are configured properly, it is possible to manage the load as follows :

- control for a single load
- control for one or more load groups
- simultaneous management of all loads

It is also possible to carry out special functions, which are hard to achieve with conventional electrical systems

These functions are called scenarios

One scenario is a set of simultaneous control of multiple groups of loads, used in order to modify the environment according to the user's needs. An example of a scenario can be represented by the simultaneous activation of lights, which can be set by the user after getting inside the building by using one single control device or by using the touch screen menu

## ■ Installation principle

### Consumer unit

### Control units

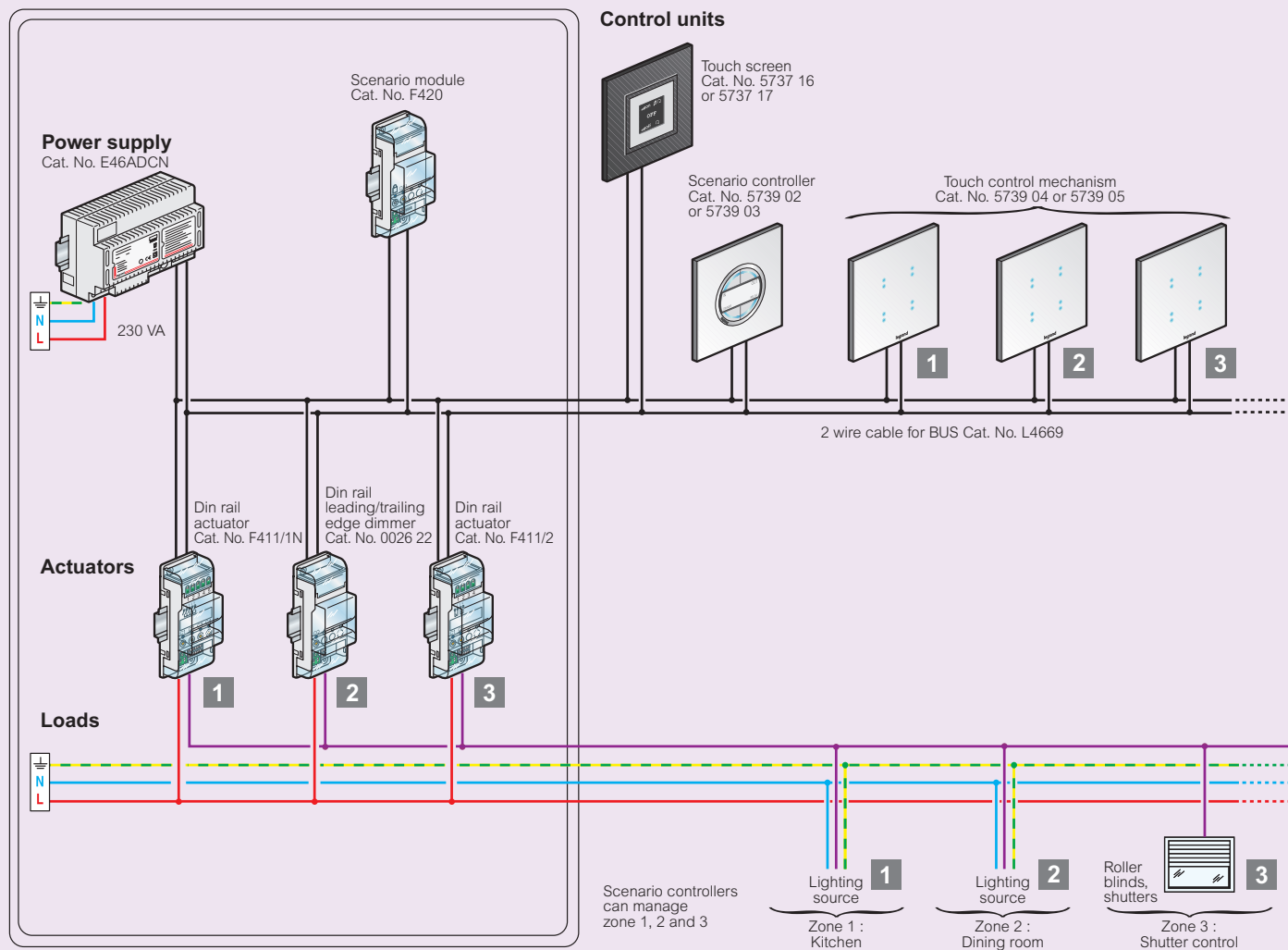

### ■ Actuators and dimmers max. loads at 230 V

		Universal									
		Leading edge				Trailing edge					
Cat. Nos.		Incandescent lamp	Halogen lamp	ELV halogen with ferromagnetic transformer	ELV halogen with electronic transformer	Fluorescent tube	Compact fluorescent lamp	LED	Fluorescent lamps with 0-10 V ballast	Reducer motor for shutter	
ACTUATORS	F411/1N	3 500 W	3 500 W	1 000 VA	1 000 VA	1 000 VA	1 000 VA	-	-	-	
	F411/2	2 300 W	2 300 W	500 VA	250 VA	250 VA	250 VA	-	-	500 VA	
	F411/4	1 400 W	1 400 W	500 VA	70 VA	70 VA	70 VA	-	-	500 VA	
	0026 01	2 x 3 600 W	2 x 3 600 W	2 x 3 600 VA	2 x 1 000 VA	2 x 1 000 VA	-	-	-	-	
	0026 02	4 x 1 000 W	4 x 1 000 W	4 x 500 VA	4 x 500 VA	4 x 500 VA	4 x 500 VA	4 x 500 VA	-	4 x 100 VA	
DIMMERS	F413N	-	-	-	-	-	-	10 x 55 VA	10 x 55 VA	-	
	0026 11	-	-	-	-	-	-	-	1 000 VA - 50 mA	-	
	0026 21	1 000 W	1 000 W	500 VA	500 VA	-	-	-	-	-	
	0026 22	2 x 500 W	2 x 500 W	2 x 250 VA	2 x 500 VA	-	-	-	-	-	
	F414	1 000 W	1 000 W	1 000 VA	-	-	-	-	-	-	
	F415	-	-	-	400 VA	-	-	-	-	-	
	F418	300 W	300 W	-	300 VA	-	300 VA	300 VA	-	-	

# Arteor™ BUS/SCS temperature control



5739 19



5739 20



5739 23



5739 24



5737 16



Full technical guide available to download at [www.legrand.co.uk](http://www.legrand.co.uk)



Support frames and surround plates selection charts **p. 30-31**

Technical information : [www.legrand.co.uk/arteor-building-automation](http://www.legrand.co.uk/arteor-building-automation) and follow the link to 'Arteor project and technical guide'

Pack	Cat. Nos.	Central units for temperature control	Pack	Cat. Nos.	DIN rail actuators 100/240 V~ 50/60 Hz
1	<div style="display: flex; justify-content: space-around;"> <div style="text-align: center;">  White                 </div> <div style="text-align: center;">  Magnesium                 </div> </div> 5739 18   5739 19	<p>Equipped with white or magnesium square version keypad cover plates, to be equipped with special surround plates (p. 30-33)</p> <p>Supplied with support frame, flush mounting box and 7.2 V battery Cat. No. 0675 18</p> <p>Temperature control central unit Can manage up to 99 zones</p>	1	F430/2	<p><b>Actuator with 2 independent relays</b> For single and double loads : 6 A resistive 3 A motorised valves and pumps 2 DIN modules 17.5 mm Replaces Cat. No. 0035 79</p> <p><b>Actuator with 4 independent relays</b> For single, double or mixed loads : 6 A resistive 3 A motorised valves, pumps and fan-coils 2 DIN modules 17.5 mm Replaces Cat. No. 0035 80</p>
1	<div style="display: flex; justify-content: space-around;"> <div style="text-align: center;">  White                 </div> <div style="text-align: center;">  Magnesium                 </div> </div> 5739 20   5739 21	<p><b>Probes</b></p> <p>To control the room temperature of heating and cooling system Equipped with white or magnesium square version cover plates, to be equipped with surround plates (p. 30-33) To be installed in flush mounting boxes 2 module mechanisms 22.5 x 45 mm</p> <p>Temperature setting range : from 3 °C to 40 °C</p>	1	E46ADCN	<p><b>BUS power supplies</b></p> <p><b>27 V= - 1.2 A</b> Input voltage : 230 V~ output voltage 27 V= Maximum consumption : 300 mA Maximum current supplied : 1.2 A 8 DIN modules 17.5 mm Replaces Cat. No. 0035 60</p>
1	<div style="display: flex; justify-content: space-around;"> <div style="text-align: center;">  White                 </div> <div style="text-align: center;">  Magnesium                 </div> </div> 5739 22   5739 23	<p>Temperature setting range : from 3 °C to 40 °C with dial for adjustment of +/- 3 °C relative to the set temperature and for the modality selection</p>	1	E49	<p><b>27 V= - 0.6 A</b> Input voltage : 230 V~ output voltage 27 V= Maximum current supplied : 0.6 A 2 DIN modules 17.5 mm</p>
1	<div style="display: flex; justify-content: space-around;"> <div style="text-align: center;">  White                 </div> <div style="text-align: center;">  Magnesium                 </div> </div> 5739 24   5739 25	<p>Temperature setting range : from 3 °C to 40 °C with manual/automatic speed selection for fan-coil</p>	1	3506	<p><b>Battery for temperature control central unit</b></p> <p>7.2 V battery for central unit Replaces Cat. No. 0675 18</p>
1	<div style="display: flex; justify-content: space-around;"> <div style="text-align: center;">  White                 </div> <div style="text-align: center;">  Magnesium                 </div> </div> 5737 16   5737 17	<p><b>Touch screens</b></p> <p>Equipped with white or magnesium surround, to be equipped with surround plates (p. 30-33)</p> <p>1.2" OLED touch screen for management of max. 4 functions sound system, temperature control, 4 scenarios, energy management 2 module plates</p>	1	L4669	<p><b>SCS cables</b></p> <p>2 wire cable for BUS system Conform to IEC 45-5 and IEC 20-20 Length 100 m. Supplied on wooden reels Replaces Cat. No. 0492 31</p>
1	<div style="display: flex; justify-content: space-around;"> <div style="text-align: center;">  White                 </div> <div style="text-align: center;">  Magnesium                 </div> </div> 5739 22   5739 23	<p>Temperature setting range : from 3 °C to 40 °C with dial for adjustment of +/- 3 °C relative to the set temperature and for the modality selection</p>	1	L4669/500	<p>Length 500 m. Supplied on wooden reels Replaces Cat. No. 0492 32</p>
1	<div style="display: flex; justify-content: space-around;"> <div style="text-align: center;">  White                 </div> <div style="text-align: center;">  Magnesium                 </div> </div> 5739 24   5739 25	<p>Temperature setting range : from 3 °C to 40 °C with manual/automatic speed selection for fan-coil</p>	1	L4669KM1	<p>Length 1000 m. Supplied on wooden reels Replaces Cat. No. 0492 32</p>
1	<div style="display: flex; justify-content: space-around;"> <div style="text-align: center;">  White                 </div> <div style="text-align: center;">  Magnesium                 </div> </div> 0674 59	<p><b>Display thermostat</b></p> <p>Flush mounted thermostat with backlit display. Can be used to control the temperature of an individual zone, both if a temperature central unit is and is not present. Features a temperature probe and an input for the connection of a contact line (e.g. window contact). Can be used for the management of different types of systems, and the adjustment of the fan speed when fan coils are used. Possibility of automatic operation (summer/winter), with compatible systems. Connection to SCS BUS - 2 modules.</p>	1	3456	<p><b>IR transmitter for splitter</b></p> <p>For controlling splitters in different modes (auto-hot- cold) Management of On/Off speeds (auto-low-medium or high) Temperature range between 16-30 °C Air conditioning remote control can "learn" the IR signal Can be installed behind the air conditioning unit Supplied complete with 2 m cable Replaces Cat. No. 0883 01</p>

Available  
September 2013

**Plug-in jumpers** (p. 15)



3522







F520



3508BUS



Technical information : [www.legrand.co.uk/arteor-building-automation](http://www.legrand.co.uk/arteor-building-automation) and follow the link to 'Arteor project and technical guide'

Pack	Cat.Nos	Consumption indicators	Pack	Cat.Nos	IP data concentrator
1	3522	<p><b>Pulse counter interface</b></p>  <p>Used to store data from a pulse counter : water, colorimetry, heat or gas In countries where there is ATEX Directive it is mandatory to use a zener barrier/galvanic insulation barrier between the pulse counter interface and the gas meter The barrier must answer to the ATEX directive and must be installed outside ATEX area Install one pulse counter interface per meter to measure the consumption individually Consumption data stored hour by hour, and kept for several years (12 years) Display can be in the form of histograms or statistical data Use a touch screen Cat. Nos. 5739 58 and 0672 67/68 (p. 25) to display the consumption of the various meters Replaces Cat. No. 0035 54</p>	1	F524	 <p>Used to display the data measured by the system via several web pages Can handle different billing rates Integrated memory for up to 10 pulse counter circuits Centralises the data from circuits/pulse counter Automatic backup onto SD card Replaces Cat. No. 0035 66</p>
1	F520	<p><b>Consumption indicator for 3 circuits</b></p>  <p>For single phase installations Supplied with a toroid and its link Each toroid can monitor one circuit The consumption indicator can take up to 3 toroids, for monitoring 3 separate circuits Several consumption indicators can be installed to monitor more than 3 circuits on the installation Instantaneous and cumulative display of the consumption for each circuit and display of consumption on touch screens Cat. Nos. 5739 58 and 0672 67/68 (p. 25) Display can be in the form of histograms or statistical data Consumption data can be stored for 1 year, hour by hour, 2 years day by day or 12 years month by month Replaces Cat. No. 0035 55</p>	10	3508BUS	<p><b>Connectors</b></p>  <p>Spare parts for consumption indicator Cat. No. F520 (see opposite)</p> <p>BUS connector, depth 3-81 mm Replaces Cat. No. 0492 44</p>
1	3523	<p><b>Additional toroid</b></p>  <p>Operates with consumption indicator Cat. No. F520 (see above) Cable cross section 25 mm<sup>2</sup> max. Replaces Cat. No. 0035 56</p>	10	3508U2	2-pole connector Replaces Cat. No. 0492 45
			10	3508U3	3-pole connector Replaces Cat. No. 0492 46



# Arteor™ BUS/SCS temperature control

## ■ Installation principle

### Consumer unit

### Control units

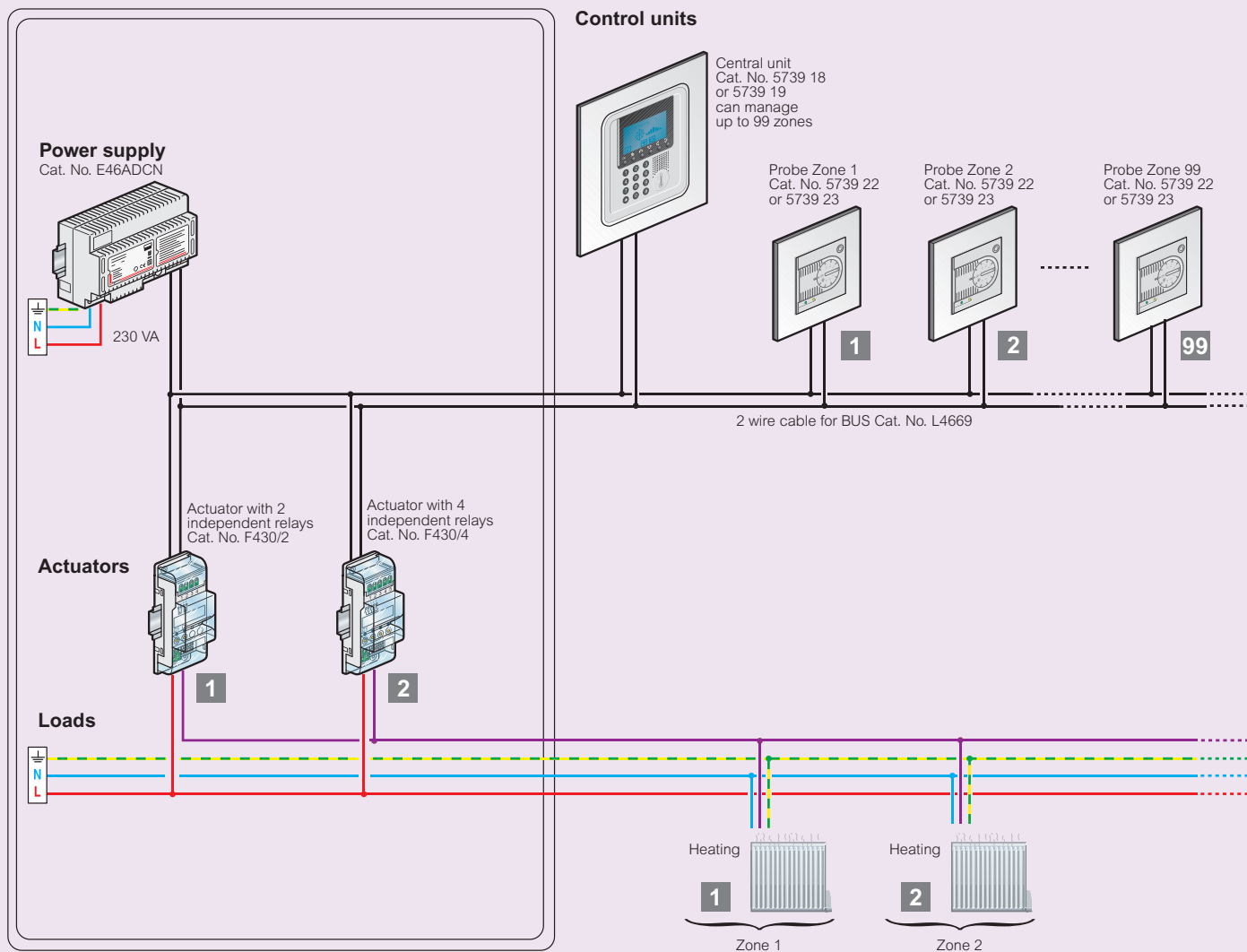







# Arteor™ BUS/SCS

sound distribution





Support frames and surround plates selection charts **p. 30-33**  
 Technical information : [www.legrand.co.uk/arteor-building-automation](http://www.legrand.co.uk/arteor-building-automation) and follow the link to 'Arteor project and technical guide'

Pack	Cat. Nos.	Amplifiers
1	0675 55	<b>Flush mounting amplifier</b>  2 x 1 Wrms - 2 modules To be equipped with round version key covers (below) and surround plates (p. 30-33) Replaces Cat. No. 5739 76
1	F502	<b>DIN rail amplifiers</b> 2 Wrms (1 Wrms + 1 Wrms) - 100/240 V~, 4 DIN modules Replaces Cat. No. 0035 85
1	F503	60 Wrms (30 Wrms + 30 Wrms) - 100/240 V~, 10 DIN modules Replaces Cat. No. 0035 83
		<b>1 module key covers</b> For flush mounting amplifier Cat. No. 5739 76
5	White 5745 11   Magnesium 5745 12	 Right-hand side mounting with marking
5	5745 05   5745 06	 Left-hand side mounting with marking
5	5744 91   5744 90	 Right-hand side mounting
5	5744 87   5744 86	 Left-hand side mounting

Pack	Cat. Nos.	RCA inputs
1	White 5739 26   Magnesium 5739 27	Equipped with white or magnesium square version cover plate, to be equipped with surround plates (p. 30-33)  For connecting a stereo source to the system 2 module mechanism

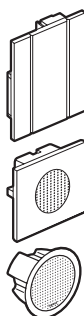
Pack	Cat. Nos.	Loudspeakers
1	White 5739 28   Magnesium 5739 29	<b>Flush mounting</b> 8 ohms – 100 W To be installed in flush mounting box min. depth 80 mm
1	5739 77	16 ohms – 12 W To be installed in flush mounting box Cat. Nos. 0893 79 or 0892 79 (opposite)
1	L4566	<b>False ceiling mounting</b> 8 ohms – 100 W. Ø 240 mm Replaces Cat. No. 5739 81

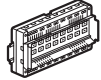
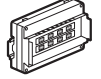

Pack	Cat. Nos.	Touch screens
1	White 5737 16   Magnesium 5737 17	Equipped with white or magnesium surround, to be equipped with surround plates (p. 30-33)  1.2" OLED touch screen for management of max. 4 functions sound system, temperature control, 4 scenarios, energy management 2 module plates

Pack	Cat. Nos.	Audio/video signal distribution devices
1	F441M	 Multi-channel matrix with cross-connection, mixing switch functions for distribution of the stereo sound source signal and audio/video signals 8 inputs (first 4 for the 2 wire audio/video system and others for stereo sound source) 8 outputs. 10 DIN modules Replaces Cat. No. 0035 84
1	F441	 Audio/video node for mixing audio/video sources (max. 4 sources) 6 DIN modules Replaces Cat. No. 5739 98

Pack	Cat. Nos.	DIN RDS radio sources
1	F500N	 RDS stereo radio tuner with coaxial connector for external aerial antenna Supplied with depth compensator for DIN rail. 4 DIN modules Replaces Cat. No. 0035 82

Pack	Cat. Nos.	DIN stereo control sources
1	L4561N	 For stereo sources IR remote control possible RCA/RCA and jack cables to connect to IR transmitters 4 DIN modules Replaces Cat. No. 0035 86

Pack	Cat. Nos.	Flush mounting boxes
2	0893 79	For loudspeaker Cat. No. 5739 77
2	0892 79	For dry partitions - 2 x 3 modules For concrete walls - 2 x 3 modules

# Arteor™ BUS/SCS

## sound distribution (continued)



5739 32



3495

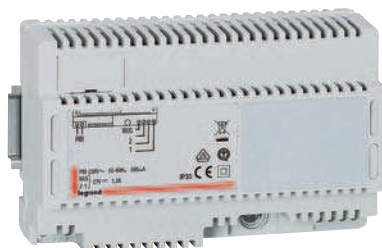

3460 00



Support frames and surround plates selection charts **p. 30-33**

Technical information : [www.legrand.co.uk/arteor-building-automation](http://www.legrand.co.uk/arteor-building-automation) and follow the link to 'Arteor project and technical guide'

Pack	Cat. Nos.	Connectors
1	White 5739 32   Magnesium 5739 33	Equipped with white or magnesium square version cover plates, to be equipped with surround plates (p. 30-33) 1 module mechanism 8 contact connector to link interface Cat. No. 0035 86 to the BUS
1	3499	<b>Attenuator</b> To be connected at the end of the line of the outputs of audio/video node and multi-channel matrix Replaces Cat. No. 0035 89
1	3495	<b>Insulator</b> Adapts the signal coming from external sound sources to the sound distribution system Replaces Cat. No. 5739 88
1	3496	<b>Sound output</b> Sound output for touch screen 3.5" (p. 19) Works as a source for sound diffusion system Replaces Cat. No. 5740 44

Pack	Cat. Nos.	BUS power supplies
1	3460 00	<b>Power supply unit for sound system</b> Input voltage : 230 V~ Output voltage : 27 V= Maximum consumption 1 A 8 DIN modules Replaces Cat. No. 0634 35
1	E49	<b>27 V= - 0.6 A</b> Input voltage : 230 V~ Output voltage : 27 V= Maximum current supplied 0.6 A 2 DIN modules
1	3369 04	<b>BUS cable</b> For sound distribution and video door entry system 200 m Replaces Cat. No. 5739 99

■ Installation principle

Consumer unit

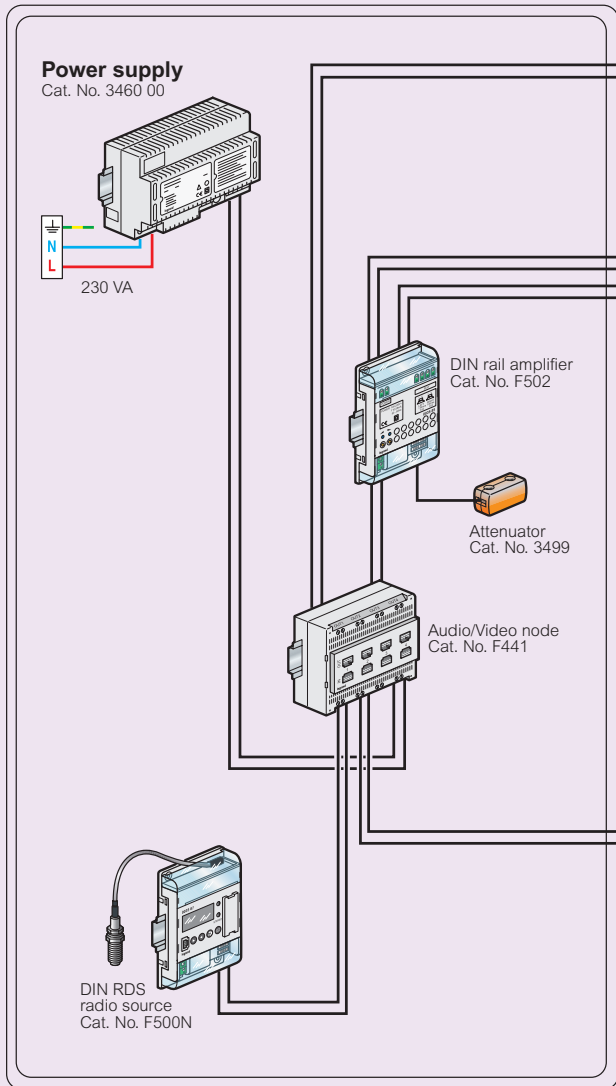

Control units

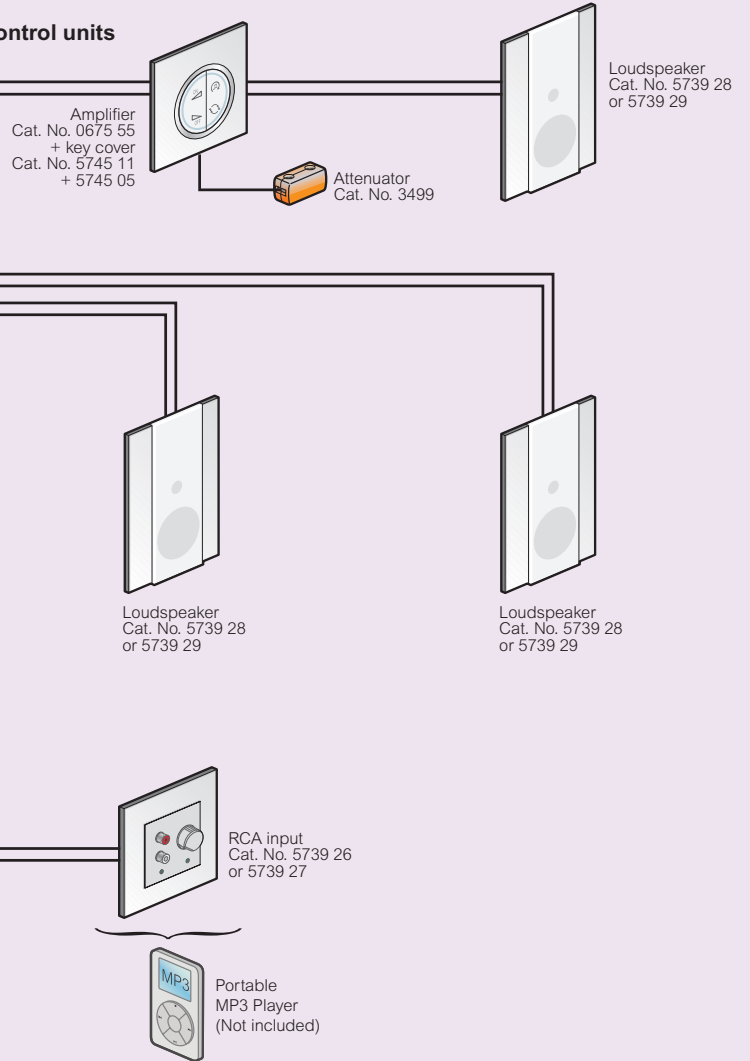

# Arteor™ BUS/SCS

## home management system



5737 16



5739 58



0672 67



Full technical guide available to download at [www.legrand.co.uk](http://www.legrand.co.uk)

Support frames and surround plates selection charts **p. 30-33**  
 Technical information : [www.legrand.co.uk/arteor-building-automation](http://www.legrand.co.uk/arteor-building-automation) and follow the link to 'Arteor project and technical guide'

Pack	Cat. Nos.	Local management	Pack	Cat. Nos.	Remote management
1	<div style="display: flex; justify-content: space-around;"> <div style="text-align: center;">  White 5737 16         </div> <div style="text-align: center;">  Magnesium 5737 17         </div> </div>	<p><b>1-2" touch screens</b>            Equipped with white or magnesium surround, to be equipped with surround plates (p. 30-33)</p> <p> 1-2" OLED touch screen for management of max. 4 functions sound system, 4 scenarios, energy management 2 module plates</p>	1	F454	<p><b>Web server gateway TCP-IP</b>   Allows the communication between a BUS/SCS installation and a TCP/IP network            6 DIN modules 17.5 mm</p>
1	5739 58	<p><b>3-5" touch screen</b>            Supplied with support frame and with white and magnesium cover plate, to be equipped with special plates (p. 30-33)</p> <p> 3-5" touch screen to control BUS functions, lighting, temperature control, sound system, scenarios, energy management, intruder alarm            Equipped with front panel USB connector ready for open webnet programming language</p> <p>To be installed in flush mounting box            Cat. Nos. 0892 79 or 0893 79, opposite</p>	1	0492 49	<p><b>Other devices</b></p> <p><b>Supervision software</b>            Can be used in order to tune up the system's functions through a computer, and to follow them on real time basis</p>
1	<div style="display: flex; justify-content: space-around;"> <div style="text-align: center;">  White 0672 68         </div> <div style="text-align: center;">  Black 0672 67         </div> </div>	<p><b>New generation 10" multimedia video touch screen</b>            10" touch screen performing the functions of an internal unit and a touch screen            The new graphic interface enables different kinds of customisations            Integrated web navigator            It gives the possibility of controlling all functions from one single point of the home :</p> <p></p> <ul style="list-style-type: none"> <li>- performing of scenarios</li> <li>- switching on/off, and dimming of lights</li> <li>- shutter control</li> <li>- temperature display and management</li> <li>- energy management – consumption display</li> <li>- sound system management : selection of music sources, volume adjustment...</li> <li>- video door entry system call management</li> <li>- management of multimedia content (photo frame, audio player, MP3...)</li> </ul> <p>Wall mounted installation (support supplied)            Requires power supply Cat. No. 3 460 20, opposite</p>	1	MH200N	<p><b>Scenario scheduler</b>   Allows setting up of up to 300 scenarios with pre-set conditions (time and logical type)            6 DIN modules 17.5 mm            Replaces Cat. No. 0035 65</p>
1			1	3460 20	<p><b>Scenario scheduler power supply</b>   Provides power for Web server and scenario scheduler Cat. No. 0035 65            2 DIN modules 17.5 mm            Replaces Cat. No. 0634 42</p>
1			1	F450	<p><b>Open/Bacnet gateway</b>   Interface for the remote control of Bacnet devices, Fancoil units, AC units, underfloor heating and touch screens</p>
2			2	0893 79	<p><b>Flush mounting boxes</b></p> <p>For 3-5" touch screen Cat. No. 5739 58            For dry partitions - 2 x 3 modules            For concrete walls - 2 x 3 modules</p>
2			2	0892 79	

# Arteor™ BUS/SCS

## door entry system



5739 50



3491 40



5739 52

Support frames and surround plates selection charts **p. 30-33**  
 Technical information : [www.legrand.co.uk/arteor-building-automation](http://www.legrand.co.uk/arteor-building-automation) and follow the link to 'Arteor project and technical guide'

Pack	Cat. Nos.	Video internal display units
1	5739 50	Hands free internal unit 2.5" LCD colour display Possible integration in BUS system Equipped with White or Magnesium cover plates, to be equipped with special plates (p. 30-33) To be installed in flush mounting box Cat. Nos. 0893 79 or 0892 79 <input type="radio"/> White <input type="radio"/> Magnesium
1	5739 51	

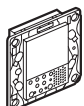

Pack	Cat. Nos.	Audio internal display units
1	5740 11 <sup>1</sup>	Equipped with: - microphone - loudspeaker - 2 hang-up push buttons - 1 door release push button - 2 auxiliary push buttons for other functions Volume adjustment for communication and call tone, and with bell cut-off indicator Allows intercom between several rooms Supplied complete with special flush mounting box, cover plate and plate <input type="radio"/> White <input type="radio"/> Magnesium
1	5743 11 <sup>2</sup>	

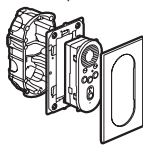

Pack	Cat. Nos.	Optional cameras
1	5739 86	<b>For outdoor use</b> 2 wire colour camera 
1	5739 52	<b>For flush mounting</b> 2 wire colour camera with swivelling lens Automatic adjustment of focus and brightness Built-in microphone Equipped with cover plates, to be equipped with support frames and surround plates (p. 30-33) To be installed in flush mounting box 2 modules <input type="radio"/> White <input type="radio"/> Magnesium
1	5739 53	
1	3460 00	<b>BUS power supply</b> Power supply unit for sound system Input voltage : 230 VA output voltage 27 V= Maximum consumption 1 A 8 DIN modules 17.5 mm Replaces Cat. No. 0634 35
2	0893 79	<b>Flush mounting boxes</b> For video display unit Cat. Nos. 5739 50/51 For dry partitions - 2 x 3 modules For concrete walls - 2 x 3 modules
2	0892 79	

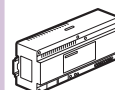

Pack	Cat. Nos.	Video/audio entrance panels
1	3491 40	<b>Entrance panel</b> Electronic module including: speaker phone module, motorised camera and colour display Possible access via integrated proximity card reader Supplied with programming and configuration software
1	3392 13	<b>Surround plate</b> Vandalproof steel finish cover plate and support frame With key for assembly
1	3393 13	<b>Flush mounting box</b> Vandalproof flush mounting box

1 : Supplied with White plate  
 2 : Supplied with Mirror Black plate

# Arteor™ BUS/SCS

accessories for video door entry system



3460 20



0408 98



3462 00



3468 30



Technical information : [www.legrand.co.uk/arteor-building-automation](http://www.legrand.co.uk/arteor-building-automation) and follow the link to 'Arteor project and technical guide'

Pack	Cat. Nos.	Accessories for video door entry systems
1	3460 20	<b>Additional power supply</b> 220-240 V - 50/60 Hz Output 1-2 27 V= 600 mA 2 DIN modules 17.5 mm Replaces Cat. No. 0634 42
1	0408 98	<b>Electric door release with latch</b> For left or right opening. 12 VA or = 6 W - 158 x 26 x 32 mm
1	3749 00	<b>Door release</b> Door release - 12 V~/880 mA
1	3462 30	<b>Relay for door release</b> Relay for 12 V= release (powered by BUS) for gate or electromagnetic lock electronic control boxes An exit push button can be connected Used to increase the time delay up to 10 minutes (set by a configuration jumper) Permissible output current : 4 A Stabilised current : 250 mA at 30 ohms 4 x 17.5 mm DIN modules Replaces Cat. No. 0634 41
1	3462 00	<b>Interface for auxiliary control</b> Relay for auxiliary commands Allows the connection of auxiliary functions such as lighting, automatic door opening... 4 DIN modules 17.5 mm To be equipped with configuration jumpers, to be ordered separately Replaces Cat. No. 0634 31
1	3501K	<b>Configuration jumpers</b> Composed of 13 jumpers no. 1, 3 jumpers no. 2, 2 jumpers no. 3, 2 jumpers no. 4, 2 jumpers no. 5, 2 jumpers no. 6, 2 jumpers no. 7, 2 jumpers no. 8, 2 jumpers no. 9, 2 jumpers no. 0 Replaces Cat. No. 0261 45
1	3462 50	<b>Door release relay</b> Door release relay NC/NO volt-free contact : max. 24 V= - 8 A resistive, 4 A inductive 2 DIN modules 17.5 mm Replaces Cat. No. 0634 33
1	3468 50	<b>Intercommunication module for up to 5 units</b> For communication between the various internal units/handsets in the house Max. capacity : 5 units 4 DIN modules 17.5 mm Replaces Cat. No. 0634 38
1	3468 51	<b>Extension interface</b> Increases the operational performance of the system (e.g. distance between the entrance panel and the internal units/handsets) Replaces Cat. No. 0634 39

Pack	Cat. Nos.	Accessories for video door entry systems (continued)
1	3468 30	<b>2 wire video adaptor</b> Use one adaptor per power supply 2 DIN modules 17.5 mm Replaces Cat. No. 0634 34
1	3468 41	<b>Video signal distributor</b> With 4 outputs for intercom module for up to 5 units Replaces Cat. No. 0634 32
1	3474 00	<b>Video signal converter</b> From coaxial to 2 wire bus for 12 V= CCTV cameras : the CCTV camera is directly supplied via a terminal Replaces Cat. No. 5740 38
1	5740 39	<b>2 wire/IP interface</b> For extended systems with IP backbone and 2 wire support
1	5740 43	<b>Virtual switchboard software</b> For managing entryphone and video entryphone calls The software (for Windows operating systems) can be installed on any fixed or mobile PC and is used to receive, manage and transfer calls from inside and outside Offers home video control with cyclical CCTV vision, day and night functions and the ability to display the alarms present in the various apartments - Operating systems supported : Microsoft Windows XP Service Pack 2 and Windows Vista - Software required : NET Framework 2.0 or later
1	F441	<b>Audio/video signal distribution devices</b> Audio/video node for mixing audio/video sources (max. 4 sources) 6 DIN modules 17.5 mm Replaces Cat. No. 5739 98
1	3369 04	<b>BUS cable</b> For sound diffusion and video door entry system 200 m Replaces Cat. No. 5739 99

## Arteor™ BUS/SCS video door entry system kits



5740 32 (see composition below)



Support frames and surround plates selection charts **p. 30-33**  
 Technical information : [www.legrand.co.uk/arteor-building-automation](http://www.legrand.co.uk/arteor-building-automation) and follow the link to 'Arteor project and technical guide'

Pack	Cat.Nos	Video door entry system kits
1	5740 32	<b>For 1 apartment</b> Comprising : - 1 entrance panel supplied complete with special flush mounting box - 1 hands free video internal unit equipped with colour display and supplied with special flush mounting box, support frame and Mirror white surround plate - 1 power supply - 1 video adaptor Possibility to install up to 4 internal video or audio units
1	5740 33	<b>For 2 apartments</b> Comprising : - 1 entrance panel supplied complete with special flush mounting box - 2 hands free video internal units equipped with colour display and supplied with special flush mounting box, support frame and Mirror white surround plate - 1 power supply - 1 video adaptor Possibility to install up to 2 internal video or audio units

## Arteor™ BUS/SCS video and audio door entry systems

### Dimensions of video internal display units Cat. Nos. 5739 50/51

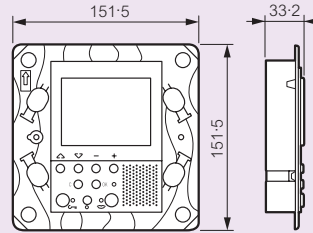

### Installation distances for video door entry systems

	Video internal unit	Power supply	Entrance panel
> 0.2 mm <sup>2</sup>	50 m	50 m	50 m (total max. distance)
PT278 (28 mm <sup>2</sup> )	90 m	115 m	150 m (total max. distance)
SYT 6/10-SYT 5/10 (0.5 mm <sup>2</sup> )	60 m	80 m	140 m (total max. distance)
SYT 9/10-SYT 8/10 (1 mm <sup>2</sup> )	200 m	200 m	200 m (total max. distance)

	T=0	T=1	T=2	T=3	T=4	T=5	T=6	T=7	T=8
	3'	1"	3"	6"	10"	1'	6'	10'	

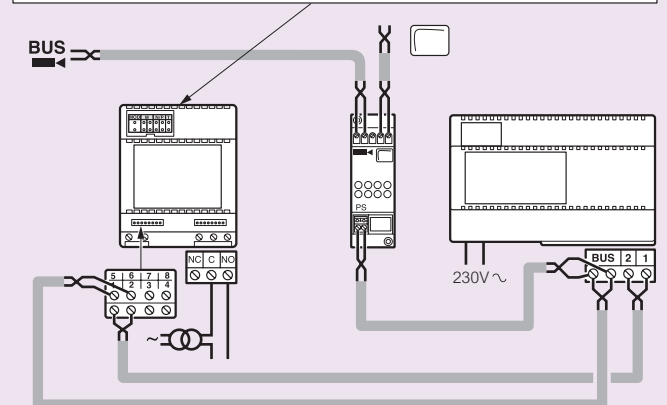

### Dimensions of audio internal units Cat. Nos. 5740 11 and 5743 11

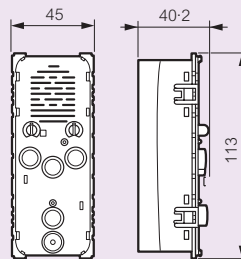

### Installation distances for audio door entry systems

	Audio internal unit	Power supply	Entrance panel	Door release
0.28 mm <sup>2</sup>	140 m	200 m	30 m	340 m
0.50 mm <sup>2</sup>	210 m	290 m	50 m	500 m
1 mm <sup>2</sup>	420 m	580 m	100 m	1000 m



# Arteor™ BUS/SCS

hotel equipment



0675 90



0675 92



5745 91



Support frames and surround plates selection charts **p. 30-33**

Technical information : [www.legrand.co.uk/arteor-building-automation](http://www.legrand.co.uk/arteor-building-automation) and follow the link to 'Arteor project and technical guide'

Pack	Cat.Nos	Control indicators for room management	
1	0675 90		DO NOT DISTURB – MAKE UP THE ROOM external indicator and bell push button
1	0675 91		DO NOT DISTURB – MAKE UP THE ROOM external + indicator and bell push button + badge reader
1	0675 93		DO NOT DISTURB – MAKE UP THE ROOM command to be completed with key covers
1	0675 92		8 push buttons control for lighting, automation, sound diffusion and scenario functions
A5 sheets for the customisation of the symbols of Cat. No. 0675 92			
1	3541	<input type="radio"/>	White
1	3542	<input checked="" type="radio"/>	Magnesium

Pack	Cat.Nos	Key-cover with symbols for control mechanism BUS/SCS	
Available September 2013			
1	5743 46		<input type="radio"/> White
1	5743 47		<input checked="" type="radio"/> Magnesium
1	5743 48		<input type="radio"/> White
1	5743 49		<input checked="" type="radio"/> Magnesium
Couple of key cover with symbol DO NOT DISTURB and symbol PLEASE CLEAN THE ROOM			
1	5743 94		<input type="radio"/> White
1	5743 95		<input checked="" type="radio"/> Magnesium
1	5743 96		<input type="radio"/> White
1	5 743 97		<input checked="" type="radio"/> Magnesium

Pack	Cat.Nos	Display thermostat	
Available September 2013			
1	0674 59		Flush mounted thermostat with backlit display. It can be used to control the temperature of an individual zone, both if a temperature central unit is and is not present. It features a temperature probe and an input for the connection of a contact line (e.g. window contact). It can be used for the management of different types of systems, and the adjustment of the fan speed when fan coils are used. Possibility of automatic operation (summer/winter), with compatible systems. Connection to SCS BUS – 2 modules

Pack	Cat.Nos	BUS/SCS keycard switches	
Equipped with rocker plates, to be equipped with support frames and surround plates (p. 30-33) For energizing a circuit by inserting a key fob Time delay of approx. 30 sec. after card removal Lighting of the slot by LED 2 modules			
1	5722 36		<input type="radio"/> White
1	5727 36		<input checked="" type="radio"/> Magnesium
<b>For RFID keycard switches</b>			
1	0767 11		MIFARE contactless badge card ISO format (50 x 80 mm) Chip : 13.56 MHz Standard 1 KB memory

Pack	Cat.Nos	Scenario controllers BUS/SCS	
Touch control plates, supplied complete, to be installed in flush mounting boxes			
<b>4-scene touch control - 4 scenarios</b> "wake up / sleep / TV / relax" scenarios - 2 modules For BS flush mounting boxes			
1	5740 89		<input type="radio"/> White
1	5745 89		<input checked="" type="radio"/> Black
<b>6-scene touch control - 6 scenarios</b> "wake up / sleep / TV / relax / open curtains / close curtains" scenarios - 3 modules For British, Italian and American flush mounting boxes			
1	5740 91		<input type="radio"/> White
1	5745 91		<input checked="" type="radio"/> Black

Pack	Cat.Nos	IP Scenario module	
Available September 2013			
1	MH201		Manages scenarios related to hotel rooms (with basic time and logic conditions) Works as a gateway for the Configuration software
<b>Monitoring software</b>			
Software for the monitoring of the status of the room, for the corresponding basic management and the programming of badges			
1	3544SW	For hotels with up to 20 rooms	
1	3546SW	As above – for hotels over 20 rooms	

ZigBee®: Certified product Manufacturer Specific Profile

# Arteor™ back boxes, support frames and surround plates

square version

Number of modules per mechanism	Back boxes	Support frames	Surround plates	SURROUND PLATES					
				Neutral			Tattoo	Graphic	
				White	Pearl Alu	Graphite	Edition 1	Casual	Formal
<b>SQUARE VERSION</b>									
1 module	1 gang <sup>1</sup>	5760 03		5752 00	5752 01	5752 02	5761 08	5761 01	5761 02
2 modules and 1-2" touch screen	1 gang <sup>1</sup>	5760 03 5760 01 <sup>3</sup>		5752 10	5752 11	5752 12	5761 28	5761 21	5761 22
3 modules - 1 gang	1 gang <sup>1</sup>	5760 01		5751 60	5751 61	5751 62	5761 88	5761 81	5761 82
3 modules and shaver sockets	2 gang <sup>2</sup>	5760 02		5750 70	5750 71	5750 72	5761 68	5761 61	5761 62
4 modules	2 gang <sup>2</sup>	5760 00		5750 80	5750 81	5750 82	5761 48	5761 41	5761 42
6 modules	5723 93 (surface mounting) 6890 27 (flush mounting)	Supplied with plate		5753 70	5753 71	5753 72	5763 78	5763 71	5763 72
2 x 6 modules	5723 96 (surface mounting) 6890 28 (flush mounting)	Supplied with plate		5753 90	5753 91	5753 92	-	-	-
3 x 6 modules	0818 56 (flush mounting)	Supplied with plate		5754 00	5754 01	5754 02	-	-	-
8 modules	8218 59 (flush mounting)	Supplied with plate		5767 00	5767 01	5767 02	5767 18	5767 11	5767 12
For 5 A/13 A switched socket outlet - 1 gang	1 gang <sup>1</sup>	Not required		5750 90	5750 91	5750 92	5762 18	5762 11	5762 12
For 13 A twin switched socket outlet - 2 gang	2 gang <sup>2</sup>	Not required		5751 00	5751 01	5751 02	5762 08	5762 01	5762 02
For 13 A fused connection unit - switched	1 gang <sup>1</sup>	Not required		5751 20	5751 21	5751 22	5761 98	5761 91	5761 92
For cooker unit Cat. No. 5720 88	2 gang <sup>2</sup>	Not required		5751 50	-	-	-	-	-
Blanking cover plate British standard	1 gang <sup>1</sup>	5760 03 or 5760 01		5751 30	5751 31	5751 32	-	-	-
Blanking cover plate British standard	2 gang <sup>2</sup>	5760 02		5751 40	5751 41	5751 42	-	-	-

**British standard 60-3 mm fixing centres**

1 : Suitable for use with 1 gang back boxes. For Legrand options, see wiring devices catalogue  
 2 : Suitable for use with 2 gang back boxes. For Legrand options, see wiring devices catalogue

**SURROUND PLATES**

	Mirror				Brushed metal		Wood		Leather		Signature
	Mirror white	Mirror black	Mirror red	Mirror taupe	Stainless steel	Gold brass	Wenge style	Light oak	Club	Galuchat	Woven metal
5752 04	5752 03	5761 06	5761 05	5752 06	5761 00	5752 05	5761 09	5761 03	5761 04	5761 07	
5752 14	5752 13	5761 26	5761 25	5752 16	5761 20	5752 15	5761 29	5761 23	5761 24	5761 27	
5751 64	5751 63	5761 86	5761 85	5751 66	5761 80	5751 65	5761 89	5761 83	5761 84	5761 87	
5750 74	5750 73	5761 66	5761 65	5750 76	5761 60	5750 75	5761 69	5761 63	5761 64	5761 67	
5750 84	5750 83	5761 46	5761 45	5750 86	5761 40	5750 85	5761 49	5761 43	5761 44	5761 47	
5753 74	5753 73	5763 76	5763 75	5753 76	5763 70	5753 75	5763 79	5763 73	5763 74	5763 77	
-	-	-	-	-	-	-	-	-	-	-	
-	-	-	-	-	-	-	-	-	-	-	
5767 04	5767 03	5767 16	5767 15	5767 06	5767 10	5767 05	5767 19	5767 13	5767 14	5767 17	
5750 94	5750 93	5762 16	5762 15	5750 96	5762 10	5750 95	5762 19	5762 13	5762 14	5762 17	
5751 04	5751 03	5762 06	5762 05	5751 06	5762 00	5751 05	5762 09	5762 03	5762 04	5762 07	
5751 24	5751 23	5761 96	5761 95	5751 26	5761 90	5751 25	5761 99	5761 93	5761 94	5761 97	
-	-	-	-	-	-	-	-	-	-	-	
-	-	-	-	-	-	-	-	-	-	-	
-	-	-	-	-	-	-	-	-	-	-	

## Arteor™ back boxes, support frames and surround plates

round version

Number of modules per mechanism	Back boxes	Support frames	Surround plates	SURROUND PLATES					
				Neutral			Tattoo	Graphic	
				White	Pearl Alu	Graphite	Edition 1	Casual	Formal
ROUND VERSION									
2 modules	1 gang <sup>1</sup>	5760 03		5756 10	5756 11	5756 12	5761 18	5761 11	5761 12
3 modules	2 gang <sup>2</sup>	5760 02		5755 40	5755 41	5755 42	5761 58	5761 51	5761 52
3 modules - 1 gang	1 gang <sup>1</sup>	5760 01		5755 60	5755 61	5755 62	5761 78	5761 71	5761 72
4 modules	2 gang <sup>2</sup>	5760 00		5755 50	5755 51	5755 52	5761 38	5761 31	5761 32
6 modules	6890 27 (flush mounting)	Supplied with plate		5767 40	5767 41	5767 42	5767 58	5767 51	5767 52
2 x 6 modules	6890 28 (flush mounting)	Supplied with plate		5756 90	5756 91	5756 92	-	-	-
8 modules	8218 59 (flush mounting)	Supplied with plate		5766 80	5766 81	5766 82	5766 98	5766 91	5766 92

### British standard 60·3 mm fixing centres

1 : Suitable for use with 1 gang back boxes. For Legrand options, see wiring devices catalogue  
 2 : Suitable for use with 2 gang back boxes. For Legrand options, see wiring devices catalogue

## Arteor™ back boxes and surround plates

special items

Mechanisms	Flush mounting boxes for dry partitions	Surround plates	SURROUND PLATES						
			Neutral			Tattoo	Graphic		
			White	Pearl Alu	Graphite	Edition 1	Casual	Formal	
Video internal display unit 2·5" BUS alarm module 3·5" touch screen	0893 79 (concrete walls) 0892 79 (dry partition walls)		-	-	-	-	-	-	-
Central unit for temperature control	Supplied with box		-	-	-	-	-	-	-

**SURROUND PLATES**

	Mirror				Brushed metal		Wood		Leather		Signature
	Mirror white	Mirror black	Mirror red	Mirror taupe	Stainless steel	Gold brass	Wenge style	Light oak	Club	Galuchat	Woven metal
5756 14	5756 13	5761 16	5761 15	5756 16	5761 10	5756 15	5761 19	5761 13	5761 14	5761 17	
5755 44	5755 43	5761 56	5761 55	5755 46	5761 50	5755 45	5761 59	5761 53	5761 54	5761 57	
5755 64	5755 63	5761 76	5761 75	5755 66	5761 70	5755 65	5761 79	5761 73	5761 74	5761 77	
5755 54	5755 53	5761 36	5761 35	5755 56	5761 30	5755 55	5761 39	5761 33	5761 34	5761 37	
5767 44	5767 43	5767 56	5767 55	5767 46	5767 50	5767 45	5767 59	5767 53	5767 54	5767 57	
-	-	-	-	-	-	-	-	-	-	-	
5766 84	5766 83	5766 96	5766 95	5766 86	5766 90	5766 85	5766 99	5766 93	5766 94	5766 97	

**SURROUND PLATES**

	Mirror				Brushed metal		Wood		Leather		Signature
	Mirror white	Mirror black	Mirror red	Mirror taupe	Stainless steel	Gold brass	Wenge style	Light oak	Club	Galuchat	Woven metal
5764 84	5764 83	-	-	5764 86	5764 80	-	-	-	-	5764 87	
5765 24	5765 23	-	-	5765 26	5765 20	-	-	-	-	5765 37	

# Home networks

music, video, data everywhere



With Legrand home networks users can enjoy distributed audio and video around the house as well as access to computer and telephone networks wherever needed.

With this flexibility, rooms blend seamlessly into one, yet each with the capacity for independent control, allowing users to see, hear and interact with whatever they want, wherever they want.

Users can enjoy their favourite CDs, MP3s, radio station or even the audio signal from their TV anywhere in the house. Legrand home networks will also distribute sound from a central source to speakers throughout the home.

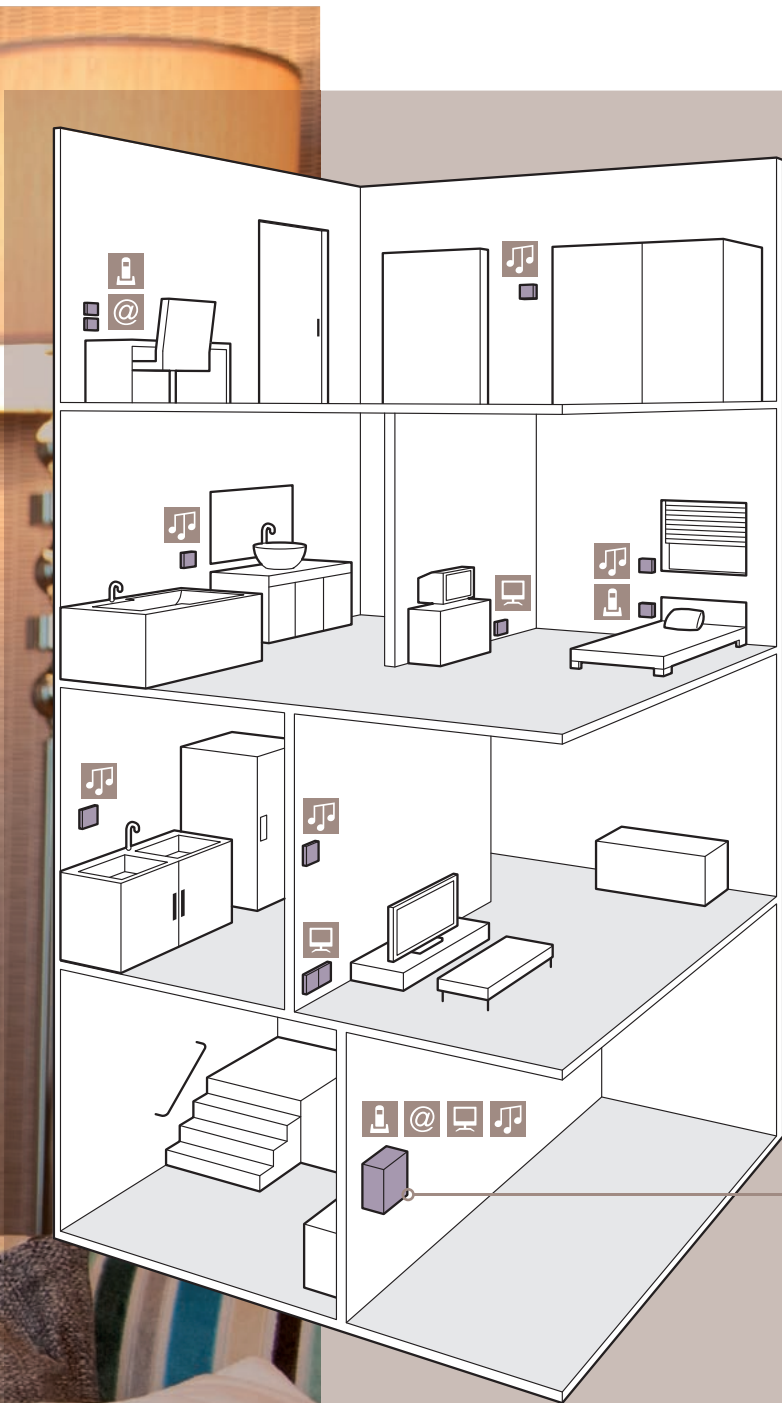

### KEYPAD VOLUME CONTROL



 (See p. 71)  
Sound distribution from a central source to loudspeakers throughout the house

### TV SOCKETS



 (See p. 128)  
Distribution of TV, VCR, DVD and HD signals from a central point to every TV set in the house

### DATA SOCKETS



 (See p. 126)  
Access high-speed internet and computer networks throughout the house. Share printers, scanners and any other connected peripherals

### TELEPHONE SOCKETS



 (See p. 128)  
For multiple telephone and fax lines into the house. With a simple 'plug and play' connection, add new phone lines as and when required

### ENCLOSURES AND MODULES



(See p. 70)  
Enclosures accept audio, video, data and telephone modules



Stunning finishes, sleek designs and unique materials are available from our Synergy and Arteor surround plate ranges.

# home networks

Arteor™ and Synergy® structured wiring



6338 01 + 6338 23 (telephone module)  
6338 26 (data module - switch)  
6338 28 (video module)



6338 02



6338 21



6338 53



6338 27



6339 93



6338 25



Installation principle p. 72-73

Pack	Cat. Nos.	Enclosures
1	6338 01	Enclosures to be equipped with audio, video, data or telephone modules Capacity : 3 single size modules or 1 double size and 1 single size module Dimensions : 295 x 115 x 100 mm
1	6338 02	Capacity : 10 modules (single or double size modules can be integrated) Dimensions : 500 x 355 x 95 mm Enclosure 20" with screw on cover

Pack	Cat. Nos.	Modules
1	6338 21	<b>Advanced audio modules</b> To be installed inside enclosures Single source - 4 zone audio distribution module Size : single module
1	6338 53	4 sources, 8 zone audio distribution module High quality stereo music in 8 rooms Passes infrared remote control signals 24 V - 60 W Size : double module
1	6338 22	<b>Advanced audio modules - surface mounting</b> RCA - single source input IR engine Input gain control For surface mounting
1	6338 48	RCA - triple source input IR engine Input gain control For surface mounting
1	6338 27	<b>Video modules</b> To be installed inside enclosures 1 x 4 bi-directional passive splitter/combiner Size : single module
1	6338 28	1 x 8 bi-directional passive video splitter/combiner Size : single module
1	6338 29	2 x 2 enhanced bi-directional video amplification Size : single module

Pack	Cat. Nos.	Modules (continued)
1	6338 30	<b>Video modules (continued)</b> 1 x 4 LNB satellite diplexer Size : single module
1	6339 93	SMATV distribution over RJ 45 (5 - 2400 MHz) Size : 2 single modules Equipped with power supply and line amplifier
1	0516 93	RJ 45 - IEC patch cord for TV network Length : 2 m
1	6338 25	<b>Data modules</b> To be installed inside enclosures 4 port router/switch (10/100 Mbits) De-select routing function mechanical switch 12 - 15 V 300 mA 3.5 - 4.5 W Size : double module
1	6338 26	10/100 Base-T auto-sensing switch 5 port - Auto-configuring Provides connectivity for a local area network 12 - 15 V 300 mA 3.5 - 4.5 W Size : single module
1	6338 33	Patch cord (RJ 45 - RJ 45)
1	6338 23	<b>Telephone module</b> To be installed inside enclosures 4 x 12 telephone module High performance RJ 45 telecom distribution Provides flexibility and convenience Size : single module



# home networks

## Arteor™ and Synergy® structured wiring (continued)



6338 45



6338 50



5727 93 + 5750 71



5727 94 + 5750 71

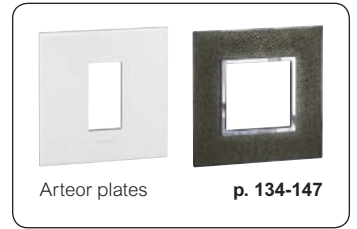

Arteor plates **p. 134-147**

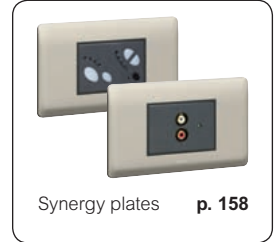

Synergy plates **p. 158**

### Installation principle **p. 72-73**

Pack	Cat. Nos.	Power supplies
1	6338 32	Multi-voltage power distribution module Distributes : - 15 V= to up to 4 locations - 12 V= to up to 2 locations - 5 V= to up to 1 location Supplied with 24" power cord jumpers
1	6338 40	15 V= power supply Includes a BS cord alimentation
1	6338 41	24 V= power supply Includes a BS cord alimentation For audio modules Cat. Nos. 6338 21/53

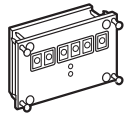

Pack	Cat. Nos.	Loudspeakers
1	6338 43	High efficiency speakers with low distortion 6.5" inch in-ceiling round speaker (pair)
1	6338 44	Dual voice coil stereo speaker 6.5" inch in-ceiling round speaker
1	6338 45	Outdoor speakers pair - 90 dB Black Also suitable for moisture rich environments such as bathrooms or saunas

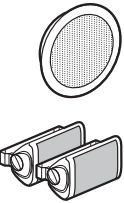

Pack	Cat. Nos.	Controls
1	6338 46	Dual IR emitter Used to control audio sources via audio distribution system To be connected on single or triple source input Cat. Nos. 6338 22/48 To be used with universal IR receiver Cat. No. 6338 47
1	6338 47	Universal IR receiver for remote control Cat. No. 6338 50 To be used with dual IR emitter Cat. No. 6338 46
1	6338 50	Universal learning remote control Control all distributed audio keypads at the same time from anywhere in the house

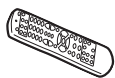

Pack	Cat. Nos.	Keypad volume control distributed audio
1	White 5722 93	<b>Arteor</b> Mechanisms equipped with white or magnesium square cover plates To be equipped with support frames and plates (p. 134-147) 3 modules 22.5 x 45 mm Built-in IR receiver
	Magnesium 5727 93	
1	White 6338 65	<b>Synergy</b> Mechanisms equipped with white or anthracite square cover plates To be equipped with support frames and plates (p. 158) 3 modules 22.5 x 45 mm Built-in IR receiver
	Anthracite 6338 64	

Pack	Cat. Nos.	RCA local source inputs
1	White 5722 94	<b>Arteor</b> Allows user to plug in devices like portable audio players and computer audio outputs Mechanisms equipped with white or magnesium square cover plates To be equipped with support frames and plates (p. 134-147) 3 modules 22.5 x 45 mm
	Magnesium 5727 94	
1	White 6338 66	<b>Synergy</b> Allows user to plug in devices like portable audio players and computer audio outputs Mechanisms equipped with white or anthracite square cover plates To be equipped with support frames and plates (p. 158) 3 modules 22.5 x 45 mm
	Anthracite 6338 68	

Pack	Cat. Nos.	Accessories
1	6338 72	<b>Brackets</b> 2 module mounting bracket Allows mounting of 2 single size modules Horizontal or vertical mounting
1	6338 73	3 module mounting bracket Allows mounting of 3 single size modules Horizontal or vertical mounting
1	6339 91	<b>RJ 45 patch panels</b> 4-way - CAT 5e RJ 45 bloc unit/UTP
1	6339 92	4-way - CAT 6 RJ 45 bloc unit/UTP

## home networks

### Arteor™ and Synergy® structured wiring - audio

#### ■ Installation principle for distributed audio system : 4 source input - 8 zones

You can listen to any one of four audio sources in up to 8 different locations at the same time

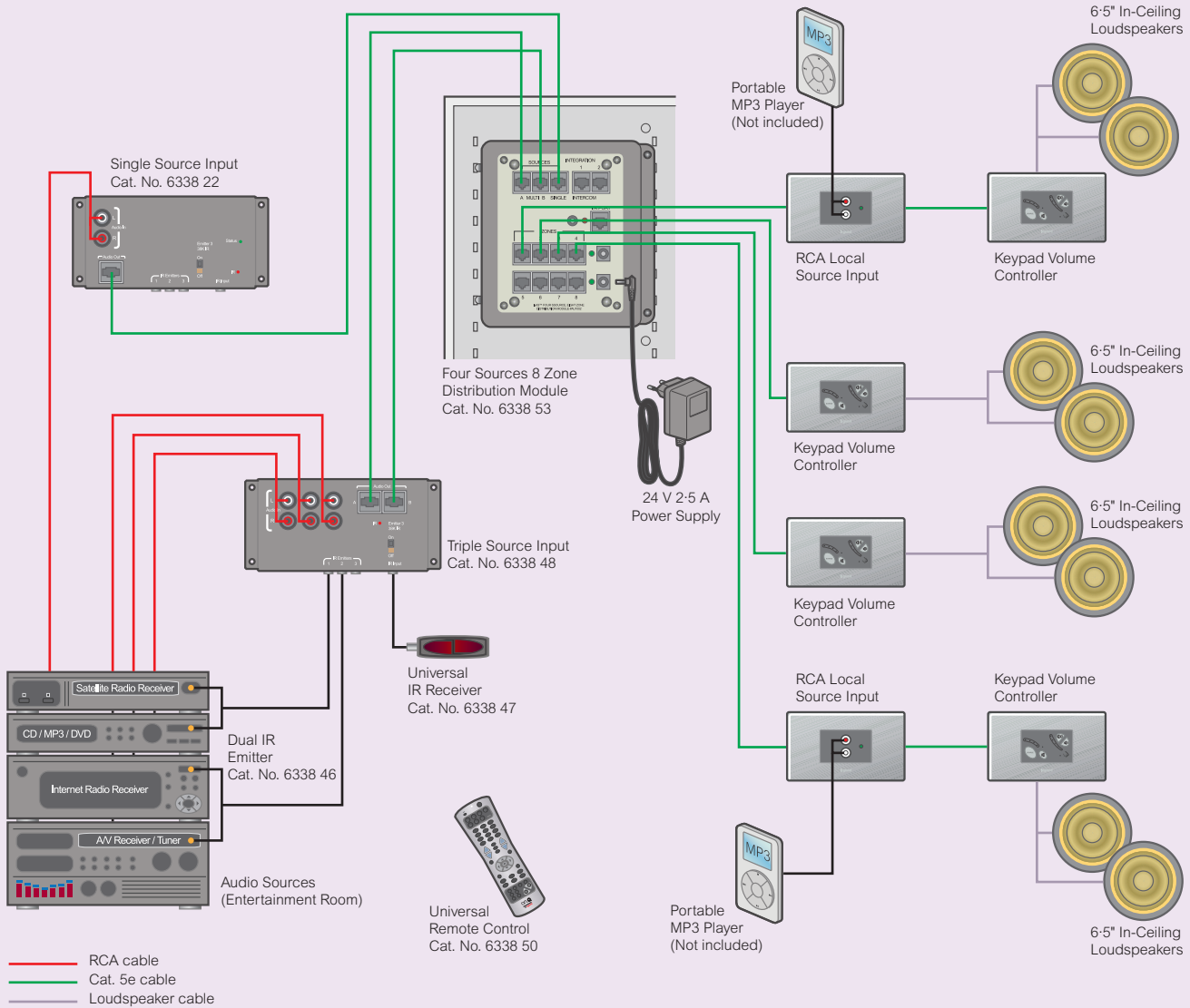

#### Technical characteristics

- High-quality stereo music in 8 rooms
- Select from four unique music sources in every room
- Amplified keypad volume controller
- Local source inputs allow different music in three rooms
- Infrared remote control for easy sound management
- Expandable up to 32 locations

#### Composition of the installation

- Keypad volume controller in each room
- Local source input in desired room (local listening)
- Loudspeakers in each room
- 4 sources 8 zone distribution module in enclosure
- Single and/or triple source input devices Cat. Nos. 6338 22 and/or 6338 48 in living room

#### ■ RJ 45 plug wiring installation

##### Plug your cable with connector

- Strip your cable and untwist the pairs
- Cut/cross all wires
- Connect wires in EZ RJ 45 connector as shown
- Crimp connector with EZ crimp tool

##### TIA 568 A wiring standard

Brown	—————	8
Brown White	- - - - -	7
Orange	—————	6
Blue White	- - - - -	5
Blue	—————	4
Orange White	- - - - -	3
Green	—————	2
Green White	- - - - -	1

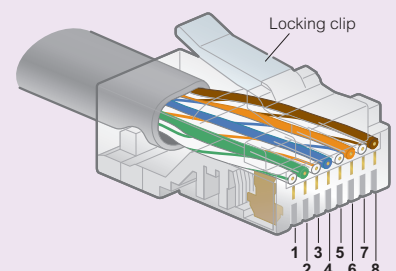

## home networks

### Arteor™ and Synergy® structured wiring - audio (continued)

#### ■ Installation principle for distributed audio system : single source input - 4 zones

You can listen to the same audio sources in up to 4 different locations at the same time

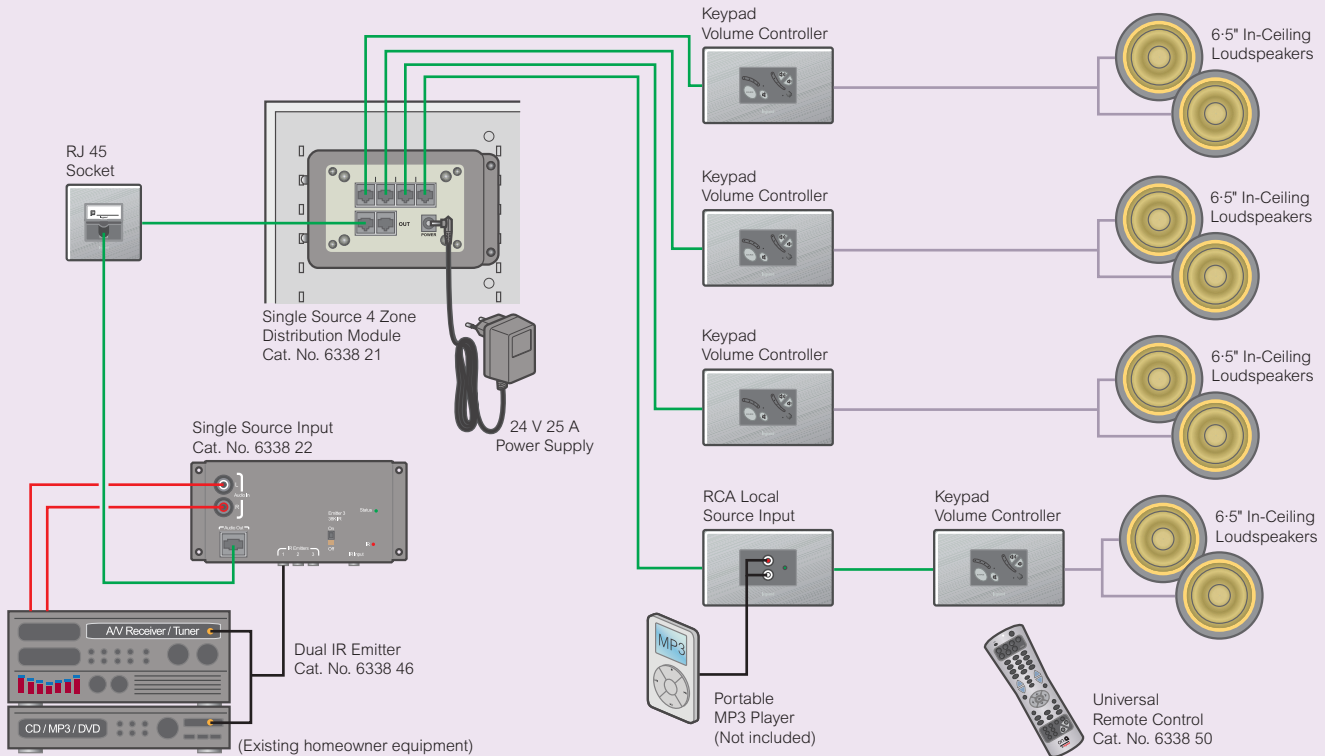

- RCA cable
- Cat. 5e cable
- Loudspeaker cable

#### Technical characteristics

- High-quality stereo music in 4 rooms
- Infrared remote control for easy sound management
- Amplified keypad volume controller

#### Composition of the installation

- Keypad volume controller in each room
- Loudspeakers for each room
- Single source 4 zone distribution module in enclosure
- Single source input device Cat. No. 6338 22 in the living room

#### ■ RJ 45 plug wiring installation

##### Plug your cable with connector

- Strip your cable and untwist the pairs
- Cut/cross all wires
- Connect wires in EZ RJ 45 connector as shown
- Crimp connector with EZ crimp tool

##### TIA 568 A wiring standard

Brown	—————	8
Brown White	- - - - -	7
Orange	—————	6
Blue White	- - - - -	5
Blue	—————	4
Orange White	- - - - -	3
Green	—————	2
Green White	- - - - -	1

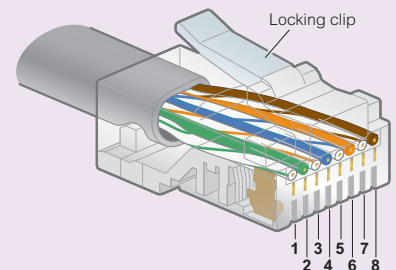



# Lighting management systems

Standalone sensors



**P. 78**  
Standalone sensors selection chart

BUS/SCS and BUS/KNX sensors



**P. 86** NEW  
BUS/SCS and BUS/KNX system sensors selection chart

BUS/SCS system



**P. 90** NEW  
BUS/SCS system room controllers selection chart

BUS/KNX system



**P. 94** NEW  
BUS/KNX system room controllers selection chart

Radio/Zigbee®

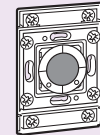

**P. 98**  
Radio/Zigbee® control units and room controllers

Building management



**P. 100** NEW  
Active building management

NEW IN 2012



**BUS/SCS and BUS/KNX sensors**  
(p. 86)



**BUS/SCS system**  
(p. 90)

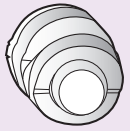

**P. 80**  
Standalone  
sensors -  
1 output

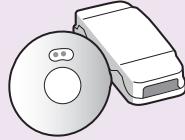

**P. 82**  
Standalone  
sensors -  
2 outputs

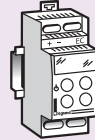

**P. 84**  
Remote  
control  
dimmers



**P. 84**  
Technical  
information



**P. 87** NEW  
BUS/SCS and  
BUS/KNX  
system sensors

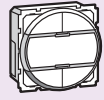

**P. 88**  
BUS/SCS and  
BUS/KNX  
system controls



**P. 89** NEW  
Select your  
system



**P. 91** NEW  
BUS/SCS system  
DIN controllers  
selection chart



**P. 92** NEW  
BUS/SCS system  
room and DIN  
controllers

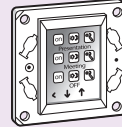

**P. 93** NEW  
BUS/SCS system  
touch screen  
control and  
DIN equipment



**P. 93** NEW  
BUS/SCS system  
software and  
accessories



**P. 95** NEW  
BUS/KNX system  
DIN controllers  
selection chart



**P. 96** NEW  
BUS/KNX system  
room and DIN  
controllers

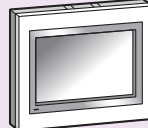

**P. 97** NEW  
BUS/KNX system  
touch screen  
control and  
interface



**P. 97** NEW  
BUS/KNX system  
installation  
supervision

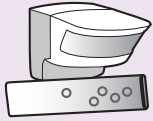

**P. 99**  
Radio/Zigbee®  
sensors and remote  
control devices



**P. 99**  
Radio/Zigbee®  
sensors and remote  
control devices  
technical information



**P. 101** NEW  
Active building  
management  
technical  
information



**BUS/KNX  
system**  
(p. 94)



**Building  
management**  
(p. 100)

# Putting a stop to energy waste

With lighting accounting for up to 20% of a commercial building's electricity use, the efficient control of lighting across all areas is a vital tool in reducing energy waste.

Our lighting management systems ensure there is just the right amount of light when and where it is needed, from simple standalone sensors to building wide lighting management using globally recognised protocols such as SCS, KNX and ZigBee.



## THE STANDALONE SOLUTION

Combining lighting management sensors with traditional light switches puts users in complete control. Lights can be manually switched on and off or, if users forget to switch off lights, the sensors will do so automatically.

### THE RIGHT TECHNOLOGY FOR EVERY ENVIRONMENT

Legrand lighting management solutions are available in three different technologies to provide effective occupancy detection in different environments... all of which can be controlled and commissioned remotely.



For small, enclosed spaces PIR sensors detect occupancy using the heat difference between people and the ambient space.



For large spaces and open areas ultrasonic sensors transmit sound waves throughout an area and measure the speed at which they come back.



For spaces with low or infrequent movement from occupants dual technology, as the name suggests, combines both infrared and ultrasonic detection.



PIR



Ultrasonic



Dual technology



## FULLY INTEGRATED LIGHTING MANAGEMENT SYSTEMS



Legrand's lighting management systems allow the user to manage and control their installation. Touch screens, mobile configurators and remote controls allow local control of the system; software packs and building management provide global management and supervision of multiple systems.

### 3 SYSTEMS: BUS/SCS, BUS/KNX AND RADIO/ZIGBEE®





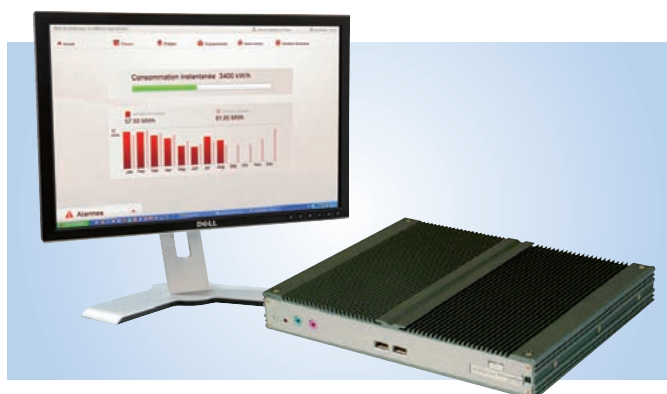



Choose from three globally recognised protocols:

- BUS/SCS: local or remote control of lighting using dedicated software
- BUS/KNX: automated control that works alongside existing applications (emergency lighting, fire alarms etc)
- Radio/ZigBee: for wireless installations and renovations where additional cabling cannot be introduced



## lighting management standalone sensors

### main characteristics and applications

















Cat. Nos.	Outputs	Operation	Installation type	Sensor technology	IP	Detection field	Diameter at 2-5 m	Recommended application
 0488 03	1	ON/OFF	ceiling	PIR	IP 20	45 m <sup>2</sup>	Ø8 m	• movement indoor
 0488 11	1	ON/OFF	wall	PIR	IP 20	45 m <sup>2</sup>	range 8 m	• movement indoor
 0697 40/80	1	ON/OFF	wall outdoor	PIR	IP 55	45 m <sup>2</sup>	range 8 m	• movement outdoor
<b>NEW</b>  5740 47/5740 97 5740 34/5740 94	1	ON/OFF	wall	PIR	IP 41	15 m <sup>2</sup>	range 8 m	• movement indoor
<b>NEW</b>  0488 05	1	ON/OFF	ceiling	US	IP 20	45 m <sup>2</sup>	Ø8 m	• restrooms • enclosed hallways • stairways
 +  0488 21 + 0488 50/51/52	2	ON/OFF/ dimming						
<b>NEW</b>  0488 06 0488 09	1	ON/OFF	ceiling	DUAL TECH	IP 20	90 m <sup>2</sup>	Ø11 m	• offices • conference rooms • classrooms
 +  0488 22 + 0488 50/51/52	2	ON/OFF/ dimming						
<b>NEW</b>  0488 07 0488 08	1	ON/OFF	ceiling	PIR	IP 20	45 m <sup>2</sup>	Ø8 m	• small offices • hallways • lobbies
 +  0488 20 + 0488 50/51/52	2	ON/OFF/ dimming						
<b>NEW</b>  0488 17	1	ON/OFF	ceiling	PIR	IP 20	30 m x 3 m	range 30 m	• corridor
<b>NEW</b>  0488 13	1	ON/OFF	wall	PIR	IP 42	length 30 m	range 30 m	• warehouse • high ceiling location
 +  0488 25 + 0488 50/51/52	2	ON/OFF/ dimming						
<b>NEW</b>  +  0488 23 + 0488 50/51/52	2	ON/OFF/ dimming	wall	DUAL TECH	IP 42	90 m <sup>2</sup>	range 11 m	• offices • conference rooms • classrooms
<b>NEW</b>  +  0488 24 + 0488 50/51/52	2	ON/OFF/ dimming	wall	PIR	IP 42	45 m <sup>2</sup>	range 8 m	• small offices • hallways • lobbies
<b>NEW</b>  0488 10	1	ON/OFF	wall outdoor	PIR	IP 55	180 m <sup>2</sup>	Ø15 m	• building entrance • warehouse • car parks
 +  0488 30 + 0488 50/51/52	2	ON/OFF/ dimming						
<b>NEW</b>  5740 49/5740 99	1	ON/OFF	wall	DUAL TECH	IP 41	15 m <sup>2</sup>	range 8 m	• offices • conference rooms
<b>NEW</b>  5740 31/5740 81	1	ON/OFF	wall	PIR	IP 41	15 m <sup>2</sup>	range 8 m	• small offices

PIR : Passive infrared technology, US : Ultrasonic technology, DUAL TECH : PIR and US technologies



# lighting management standalone sensors

## main characteristics and applications

Cat. Nos.	With/ without neutral	Power supply	TYPE OF LIGHT COMPATIBILITY							DALI ballast	Contactors
			Halogen light	ELV halogen with separate ferromagnetic or electromagnetic transformer	Fluorescent tube	Fluorescent light with separate ferromagnetic or electronic ballast	LED	Compact fluorescent light with 1-10 V ballasts	ON/OFF		
1 OUTPUT	 0488 03	With neutral	240 V	2 000 W	1 000 VA	10 x (2 x 36 W)	1 000 VA	500 W	500 W	-	max. ≤ 2 A
			100 V	1 000 W	1 500 VA	5 x (2 x 36 W)	500 VA	250 W	250 W	-	max. ≤ 2 A
	 0488 11	With neutral	240 V	2 000 W	1 000 VA	10 x (2 x 36 W)	1 000 VA	500 W	500 W	-	max. ≤ 2 A
			100 V	1 000 W	1 500 VA	5 x (2 x 36 W)	500 VA	250 W	250 W	-	max. ≤ 2 A
	 0697 40 0697 80	With neutral	240 V	2 000 W	1 000 VA	10 x (2 x 36 W)	1 000 VA	500 W	500 W	-	max. ≤ 2 A
			100 V	1 000 W	1 500 VA	5 x (2 x 36 W)	500 VA	250 W	250 W	-	max. ≤ 2 A
	 5740 47 5740 97	With neutral	240 V	2 000 W	1 000 VA	10 x (2 x 36 W)	1 000 VA	500 W	500 VA	-	max. ≤ 2 A
			100 V	1 000 W	500 VA	5 x (2 x 36 W)	500 VA	250 W	250 VA	-	max. ≤ 2 A
	 5740 34 5740 94	Without neutral	240 V	400 W max 40 W min	400 VA 40 VA	-	-	-	-	-	-
			100 V	200 W max 20 W min	200 VA 20 VA	-	-	-	-	-	-
	 0488 05	With neutral	240 V	2 000 W	1 000 VA	10 x (2 x 36 W)	1 000 VA	500 W	500 W	-	max. ≤ 2 A
			100 V	1 000 W	1 500 VA	5 x (2 x 36 W)	500 VA	250 W	250 W	-	max. ≤ 2 A
	 0488 06 0488 09	With neutral	240 V	2 000 W	1 000 VA	10 x (2 x 36 W)	1 000 VA	500 W	500 W	-	max. ≤ 2 A
			100 V	1 000 W	1 500 VA	5 x (2 x 36 W)	500 VA	250 W	250 W	-	max. ≤ 2 A
	 0488 07 0488 08	With neutral	240 V	2 000 W	1 000 VA	10 x (2 x 36 W)	1 000 VA	500 W	500 W	-	max. ≤ 2 A
			100 V	1 000 W	1 500 VA	5 x (2 x 36 W)	500 VA	250 W	250 W	-	max. ≤ 2 A
 0488 17	With neutral	240 V	2 000 W	1 000 VA	10 x (2 x 36 W)	1 000 VA	500 W	500 W	-	max. ≤ 2 A	
 0488 10	With neutral	240 V	2 000 W	1 000 VA	10 x (2 x 36 W)	1 000 VA	500 W	500 W	-	max. ≤ 2 A	
		100 V	1 000 W	1 500 VA	5 x (2 x 36 W)	500 VA	250 W	250 W	-	max. ≤ 2 A	
 0488 13	With neutral	240 V	2 000 W	1 000 VA	10 x (2 x 36 W)	1 000 VA	500 W	500 W	-	max. ≤ 2 A	
		100 V	1 000 W	1 500 VA	5 x (2 x 36 W)	500 VA	250 W	250 W	-	max. ≤ 2 A	
 5740 49/ 5740 99	With neutral	240 V	2 000 W	1 000 VA	10 x (2 x 36 W)	1 000 VA	500 W	500 VA	-	max. ≤ 2 A	
		100 V	1 000 W	500 VA	5 x (2 x 36 W)	500 VA	250 W	250 VA	-	max. ≤ 2 A	
 5740 31 5740 81	Without neutral	240 V	400 W max 40 W min	400 VA 40 VA	-	-	-	-	-	-	
		100 V	200 W max 20 W min	200 VA 20 VA	-	-	-	-	-	-	
2 OUTPUTS	 0488 50 <sup>(1)</sup>	With neutral	240 V	3 600 W	1 800 VA	1 800 VA	500 W	500 W	1 800 VA	-	max. ≤ 2 A
			100 V	1 800 W	900 VA	900 VA	250 W	250 W	900 VA	-	max. ≤ 2 A
	 0488 51	With neutral	240 V	-	-	-	-	-	-	2 x 16 ballasts	max. ≤ 2 A
			100 V	-	-	-	-	-	-	-	-
	 0488 52	With neutral	240 V	-	-	-	-	-	1 000 VA	-	-
100 V			-	-	-	-	-	500 VA	-	-	

# lighting management standalone sensors - 1 output

for areas used infrequently



0488 03



0488 11



0697 80



5740 47

Main characteristics and applications selection charts **p. 78-79**  
 Technical characteristics **p. 84-85**

Automatic lighting management in infrequently used areas : e.g. garages, storage spaces, corridors...

Mode : automatic on/off switching upon detection

Manual adjustment of light level threshold and time delay via thumbwheel/screwdriver

Pack	Cat. Nos.	<b>360° ceiling sensor (indoor) - Detection field 45 m<sup>2</sup></b>
1	0488 03	Fixed directly to a false ceiling with mounting claws (supplied) or installed in 50 mm deep flush mounting box or in surface mounting box Cat. Nos. 0488 74/75, see p. 83 PIR - Ø8 m - IP 20 Optimum distance between 2 sensors : 6 m Consumption 0.4 W on standby Automatic terminal connection All loads 8.5 A - 240 V

Pack	Cat. Nos.	<b>180° wall sensor (indoor) - Detection field 45 m<sup>2</sup></b>
1	0488 11	Supplied with fixing base PIR - Maximum range 8 m - IP 20 Optimum distance between 2 sensors : 6 m Consumption 0.4 W on standby Automatic terminal connection All loads 8.5 A - 240 V

Pack	Cat. Nos.	<b>360° wall sensors (outdoor) - Detection field 45 m<sup>2</sup></b>
1	0697 40	PIR - Maximum range 8 m - IP 55 Coverage pattern adjustable during installation process Screw terminal connection ● Grey ○ White
1	0697 80	

Pack	Cat. Nos.	<b>180° switch sensors (indoor) - Detection field 15 m<sup>2</sup></b>
<b>NEW</b>		Wall mounting PIR - Maximum range 8 m - IP 41 Screw terminal connection <b>Arteor</b> ○ White - With neutral ● Magnesium - With neutral ○ White - Without neutral ● Magnesium - Without neutral
1	5740 47	
1	5740 97	
1	5740 34	
1	5740 94	



# lighting management standalone sensors - 1 output

for areas benefitting from natural light



0488 07



0488 17



0488 13



5740 49

Main characteristics and applications selection charts **p. 78-79**  
 Technical characteristics **p. 84-85**

Automatic lighting management in areas that benefit from natural light : e.g. individual and open-plan offices, meeting rooms

Presence mode : automatic on/off switching upon detection

Absence mode : manual switching on with push button, automatic switching off

Factory pre-set : time delay 15 minutes, light level threshold 500 lux for false ceiling sensors, 300 lux for flush mounted sensors

Pack	Cat. Nos.	360° ceiling sensors (indoor)
1	0488 07	Fixed directly to a false ceiling with mounting claws (supplied) or installed in 50 mm deep flush mounting box or in surface mounting box Cat. Nos. 0488 74/75, see p. 83 <b>Detection field 45 m<sup>2</sup> - for private offices</b> PIR - Ø8 m - IP 20 Optimum distance between 2 sensors : 6 m Consumption 0.4 W on standby Absence and presence mode (push button override or mobile configurator) Automatic terminal connection All loads 8.5 A - 240 V
1	0488 08	Fast connection All loads 8.5 A - 240 V
1	0488 06	<b>Detection field 90 m<sup>2</sup> - for meeting rooms or large offices</b> Dual-tech - Ø11 m - IP 20 Optimum distance between 2 sensors : 10 m Consumption 0.8 W on standby Absence and presence mode (push button override or mobile configurator) Automatic terminal connection All loads 8.5 A - 240 V
1	0488 09	Fast connection All loads 8.5 A - 240 V
1	0488 05	<b>Detection field 45 m<sup>2</sup> - for enclosed spaces with obstacles</b> Ultrasonic - Ø8 m - IP 20 Optimum distance between 2 sensors : 6 m Consumption 0.8 W on standby Absence and presence mode (push button override or mobile configurator) Automatic terminal connection All loads 8.5 A - 240 V
1	0488 17	<b>Detection field 90 m<sup>2</sup> - for corridors or very long areas</b> PIR - 30 m <sup>2</sup> - IP 20 Optimum distance between 2 sensors : 20 m Consumption 0.4 W on standby Absence and presence mode (push button override or mobile configurator) Automatic terminal connection All loads 8.5 A - 240 V

Pack	Cat. Nos.	180° wall sensor (indoor)
1	0488 13	<b>For warehouses, corridors or very long areas</b> PIR - Maximum range 30 m - IP 42 Consumption 0.4 W on standby Detection specially adapted for long narrow areas (e.g. corridors) or very high areas (e.g. warehouses) Presence mode Automatic terminal connection All loads 2.5 A - 240 V
1	0488 10	<b>270° wall sensor (outdoor)</b> <b>Detection field 180 m<sup>2</sup> - for building entrances, car parks</b> PIR - Maximum range 15 m - IP 55 Front detection 10 m Lateral detection 30 m (2 x 15) IP 55 Consumption 0.4 W on standby Dual side detection specially adapted for wide areas (e.g. entrance hall) Absence and presence mode (push button override or mobile configurator) Automatic terminal connection All loads 8.5 A - 240 V
1	Arteor 5740 49	<b>180° switch sensors (indoor)</b> <b>Detection field 15 m<sup>2</sup> - for small conference rooms and private offices</b> Wall mounting <b>Absence mode with neutral</b> Dual-tech - Maximum range 8 m - IP 41 ○ White ● Magnesium
1	Arteor 5740 31	<b>Absence mode without neutral</b> PIR - Maximum range 8 m - IP 41 ○ White ● Magnesium

# lighting management standalone sensors - 2 outputs

for areas benefitting from natural light



Main characteristics and applications selection charts **p. 78-79**  
 Technical characteristics **p. 84-85**

Automatic lighting management in areas that benefit from natural light : e.g. individual and open-plan offices, meeting rooms + Management of an additional circuit - lighting/air conditioning/ventilation etc.

Presence mode : automatic on/off switching upon detection

Absence mode : manual switching on with push button, automatic switching off

Factory pre-set : time delay 15 minutes, light level threshold 500 lux for false ceiling sensors, 300 lux for flush mounted sensors

Precise adjustment through mobile configurators

Pack	Cat. Nos.	360° ceiling sensors (indoor)
1	0488 20	Fixed directly to a false ceiling with mounting claws (supplied) or installed in 50 mm deep flush mounting box or in surface mounting box Cat. Nos. 0488 74/75, see opposite Connect to 2 circuit controller Cat. No. 0488 50, see opposite, by cord or RJ 45 cable or BUS/SCS cable fitted with RJ 45 connector Cat. No. 0488 72, see opposite <b>Detection field 45 m<sup>2</sup> - for private offices</b> PIR - Ø8 m - IP 20 Optimum distance between 2 sensors : 6 m Consumption 0.2 W on standby RJ 45 connection All loads 10 A - 240 V
1	0488 22	<b>Detection field 90 m<sup>2</sup> - for meeting rooms or large offices</b> Dual-tech - Ø11 m - IP 20 Optimum distance between 2 sensors : 10 m Consumption 0.5 W on standby RJ 45 connection All loads 10 A - 240 V
1	0488 21	<b>Detection field 45 m<sup>2</sup> - for enclosed spaces with obstacles</b> Ultrasonic - Ø8 m - IP 20 Optimum distance between 2 sensors : 6 m Consumption 0.5 W on standby RJ 45 connection All loads 10 A - 240 V

Pack	Cat. Nos.	Wall sensors
1	0488 24	Supplied with fixing base Connect to 2 circuit controller Cat. No. 0488 50, see opposite, by cord or RJ 45 cable or BUS/SCS cable fitted with RJ 45 connector Cat. No. 0488 72, see opposite <b>180° corner sensor (indoor) - Detection field 45 m<sup>2</sup> - for small offices</b> PIR - Maximum range 8 m - IP 42 Optimum distance between 2 sensors : 6 m Consumption 0.2 W on standby RJ 45 connection All loads 10 A - 240 V
1	0488 23	<b>180° corner sensor (indoor) - Detection field 90 m<sup>2</sup> - for conference rooms and large offices</b> Dual-tech - Maximum range 11 m - IP 42 With directional head Optimum distance between 2 sensors : 10 m Consumption 0.2 W on standby RJ 45 connection All loads 10 A - 240 V
1	0488 30	<b>270° corner sensor (outdoor) - Detection field 180 m<sup>2</sup> - for building entrances, car parks</b> PIR - Maximum range 15 m - IP 55 Front detection 10 m Lateral detection 30 m (2 x 15) Consumption 0.5 W on standby RJ 45 connection All loads 10 A - 240 V

1	0488 25	<b>Special for corridors or very long areas - Detection field 30 m</b> PIR - Front range 30 m - IP 42 With directional head Specially adapted for long narrow areas Example : corridors, very high ceiling areas or warehouses
---	---------	--------------------------------------------------------------------------------------------------------------------------------------------------------------------------------------------------------------------------------------------

## lighting management standalone sensors - 2 outputs (continued)

for areas benefitting from natural light



0488 23 (see opposite)



0488 50



0488 72



0488 68



0882 35



0882 30

Main characteristics and applications selection charts **p. 78-79**  
 Technical characteristics **p. 84-85**

Automatic lighting management in areas that benefit from natural light : e.g. individual and open-plan offices, meeting rooms + Management of an additional circuit - lighting/air conditioning/ventilation etc.

Presence mode : automatic on/off switching upon detection

Absence mode : manual switching on with push button, automatic switching off

Factory pre-set : time delay 15 minutes, light level threshold 500 lux for false ceiling sensors, 300 lux for flush mounted sensors

Precise adjustment through mobile configurators

Pack	Cat. Nos.	Room controllers
1	0488 50	Ability to connect the sensor(s) and the push button(s) Fixed directly to the false ceiling via cable ducting Controller/sensor output connection (up to 10 sensors Cat. Nos. 0488 20/21/22/23/24/30, see opposite) by cord or RJ 45 cable or BUS/SCS cable to be fitted with RJ 45 connector Cat. No. 0488 72 Power supply 100/240 V <b>Room controller 2 outputs 16 A</b> Allows 2 lighting circuits to be controlled in 2 different phases or 1 lighting circuit and 1 A/C circuit
1	0488 51	<b>Room control 1 input, 2 outputs DALI/DSI</b> Controller for DALI and DSI dimming Enables the window side of a room (which benefits from natural light) and the corridor (which has less natural light) to be dimmed separately with a single sensor 1 sensor input, 2 inputs for auxiliaries, 2 DALI outputs and 1 fan output (voltage-free contact) For controlling light sources with sensors (with up to 5 sensors) : - 2 x 16 DALI/DSI ballasts Connected via screw terminals
1	0488 52	<b>Room control 1 input, 2 outputs 1-10 V</b> Dimming lighting controller 1-10 V Enables the window side of a room (which benefits from natural light) and the corridor (which has less natural light) to be dimmed separately with a single sensor 1 sensor input, 2 inputs for auxiliaries and 2 lighting outputs Connected via screw terminals

Pack	Cat. Nos.	RJ 45-BUS/SCS connector
1	0488 72	Allows controller(s) and sensor(s) to be connected directly using BUS/SCS wiring by branch connection Male connector
10	0488 68	<b>RJ 45 doubler</b> Allows the number of controller inputs to be doubled
1	0882 35	<b>Mobile configurators</b> All sensors are pre-set in the factory - lighting threshold : 500 lux in false ceiling, 300 lux surface mounted - time delay : 15 minutes and walkthrough function activated Mobile configurators allow the pre-adjusted settings and the detection sensitivity to be readjusted
1	0882 30	Step by step programming via pre-set buttons Digital programming to the nearest decimal place Instant programming control Allows the settings of each sensor to be displayed Option of putting adjustment settings in the memory and using them for other sensors
1	0882 31	<b>IR remote control - ON/OFF-dimming control</b> Allows to manage 2 directions and general switch off Powered by two 1.5 V LR 03 alkaline batteries (supplied) For remote control of sensors Cat. Nos. 0488 05/06/07/08/09/10/13/20/21/22/23/24/25 (see opposite)
5	0488 74	<b>Surface mounting boxes</b> Used for surface mounting ceiling sensors For false ceiling sensors Cat. Nos. 0488 03 (see p.80), 0488 07 (see p.81) and 0488 20 (see opposite)
5	0488 75	For false ceiling sensors Cat. Nos. 0488 05/06, 0488 17 (see p.81), 0488 21/22 (see opposite) and 0488 35 (see p.99)

## lighting management remote control dimmers



0036 59

0036 58

0036 60

Pack	Cat. Nos.	Remote control dimmers 100 - 240 V~ - 50/60 Hz	Number of modules
1	0036 59	<b>Controlled via non-illuminated push buttons</b> DIN rail mounting The last lighting level is stored into memory, in case of power cut or switch-off Direct or remote control (switching and dimming) with non-illuminated push buttons For incandescent and halogen lamps 230 V~ and ELV halogen lamps with ferromagnetic transformers Load : 60 to 600 W (for 230 V~ 50/60 Hz)	2
1	0036 58	For fluorescent lamps with 1-10 V dimmable ballast (fluorescent tubes and compact fluorescent lamps with separated dimmable ballast) Ballast power : maximum 800 VA (for 230 V~ 50/60 Hz) Control current : 50 mA	2
1	0036 71	<b>Controlled via BUS line</b> DIN rail mounting Direct or remote control (switching and dimming) with non-illuminated double push buttons or BUS peripherals (Arteor Programme) Equipped with illuminated scale indicating the light level of controlled lamps For incandescent and halogen lamps 230 V~, ELV halogen lamps with ferromagnetic or electronic transformers Load : 1000 W (for 230 V~ 50/60 Hz)	6
1	0036 60	For fluorescent lamps with 1-10 V ballast (fluorescent tubes and compact fluorescent lamps with separated ballast) Ballast power : maximum 1000 VA (for 230 V~ 50/60 Hz) Control current : 50 mA	4
1	0036 80	<b>Power supply for BUS line</b> BUS power supply for remote controlled dimmers Cat. Nos. 0036 60/71 For maximum 8 peripherals	2

## lighting management standalone sensors installation details

### ■ Ceiling mounting



All sensors have built-in bracket systems that enable ceiling mounting. Most sensors are suitable for standard EU boxes (Ø65). This is important for applications where the ceiling is unavailable for sensor installation  
Only one Cat. No. for two ways of mounting

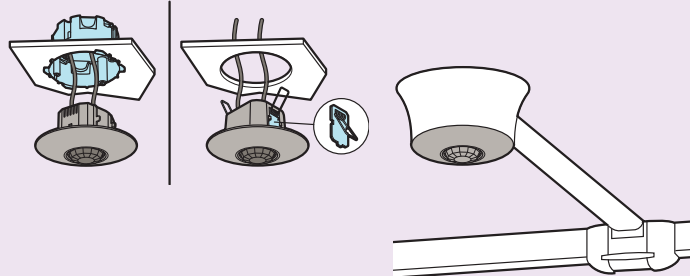

### ■ Wall mounting



Wall mounting sensors are supplied with mounting base  
Simply fix base to the wall, connect wires to the automatic wiring block and fix sensor to base

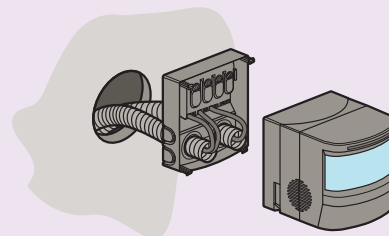

### ■ Settings

Most sensors feature Smart Factory Set technology  
Adjustments are typically not needed after installation  
If adjustments need to be made (due to last minute changes in furniture or fixture placement), sensitivity and time delays should match the activity levels of the monitored spaces

### Two commissioning tools can be used to adjust settings :

#### For standard configuration :

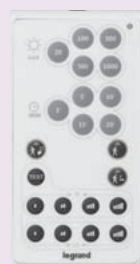

- Time level : 3, 5, 10, 15, 20 mn
- Lux level : 20, 100, 300, 500, 1000 lux
- Presence, presence walkthrough, absence modes
- PIR and US detection sensibility : low, medium, high, very high
- test mode



Presence mode



Walkthrough mode



Absence mode

Cat. No. 0882 35  
(see p. 83)

#### For advanced configuration :



This commissioning tool enables a very precise commissioning of your sensors :

- Time : from 0 seconds to 60 mn
- Lux : from 1 lux to 1275 lux
- Detection mode : presence, presence walkthrough, absence modes
- PIR and US detection sensibility : low, medium, high, very high
- Provides access to advanced functions such as calibration, alarms, choice of mode of detection (initial detection, maintain detection, retrigger), daylight function
- Allows downloading, saving and duplication of sensor parameters

Cat. No. 0882 30  
(see p. 83)

### Room controller (2 outputs)

The room controller is a key component of the lighting control system. It provides low voltage power to SCS sensors. Several sensors can be linked (up to 10). Only one Cat. No. for several applications

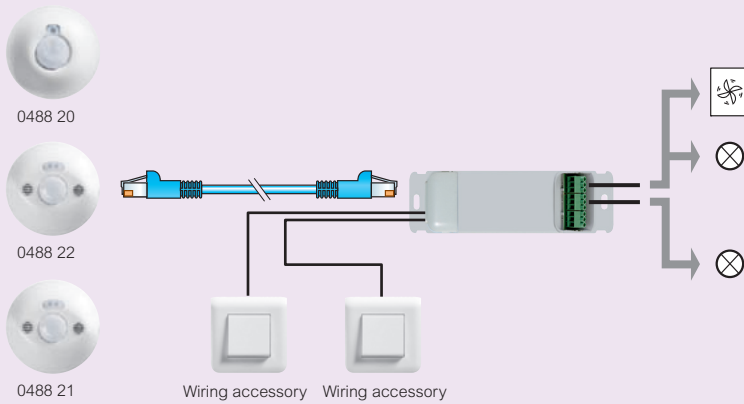

#### Product features

- > Screw terminal block
- > Auxiliary input for manual control by simple push
- > 1 RJ 45 input for SCS sensors
- > 16 A outputs for lighting and fan

### Example of installation - example of a 400 m<sup>2</sup> premises



- Bathrooms  
Archives  
Office  
**Infrared**  
45 m<sup>2</sup>
- Meeting room  
**Dual-tech**  
90 m<sup>2</sup>
- Hall  
Workshops  
Warehouses  
**Ultrasonic**  
45 m<sup>2</sup>
- Detector switches connected to push buttons  
Deliberate switch-on / automatic switch-off

Lighting accounts for up to 20% of a commercial building's electricity use

### Example of a 400 m<sup>2</sup> public building or work premises with self-contained detectors and controllers (public spaces with capacity for 50 or more people)

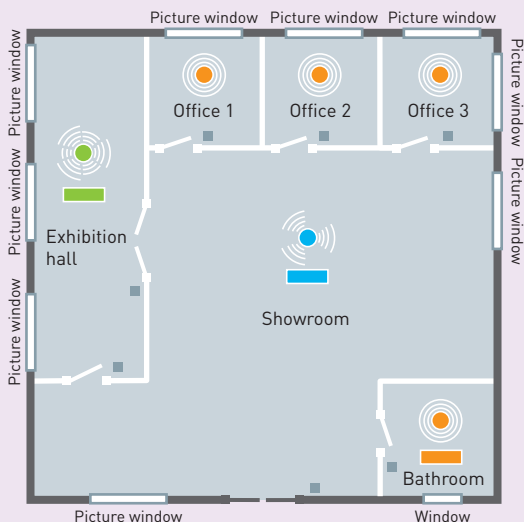

#### Work premises

3 offices regulated by self-contained ON-OFF detection - 1 output

- Infrared 360°
- Unit and detector linked to push buttons :  
Deliberate switch-on / automatic switch-off  
Possibility of illuminated push button with LED (accessibility regulations)







#### Public building

- DALI controller  
Cat. No. 0488 51
- DALI controller  
Cat. No. 0488 51
- ON-OFF controller  
Cat. No. 0488 50
- Dual-tech detector  
Cat. No. 0488 22
- Ultrasonic detector  
Cat. No. 0488 21
- Infrared detector (PIR)  
Cat. No. 0488 20

Lighting controls can provide energy savings of 30% to 55%

# lighting management BUS/SCS and BUS/KNX system sensors

## main characteristics and applications

Cat. Nos.	MAIN CHARACTERISTICS						Connection type	Recommended application
	Installation type	Sensor technology	Power supply	IP	Detection field	Diameter at 2-5 m		
 0488 20	ceiling	PIR	27 V powered by BUS/SCS or room controllers	IP 20	45 m <sup>2</sup>	Ø8 m	RJ 45	<ul style="list-style-type: none"> <li>• small offices</li> <li>• hallways</li> <li>• lobbies</li> </ul>
 0488 21	ceiling	US	27 V powered by BUS/SCS or room controllers	IP 20	45 m <sup>2</sup>	Ø8 m	RJ 45	<ul style="list-style-type: none"> <li>• restrooms</li> <li>• enclosed hallways</li> <li>• stairways</li> </ul>
 0488 22	ceiling	DUAL-TECH	27 V powered by BUS/SCS or room controllers	IP 20	90 m <sup>2</sup>	Ø11 m	RJ 45	<ul style="list-style-type: none"> <li>• offices</li> <li>• conference rooms</li> <li>• classrooms</li> </ul>
 0488 23	wall	DUAL-TECH	27 V powered by BUS/SCS or room controllers	IP 42	90 m <sup>2</sup>	range 11 m	RJ 45	<ul style="list-style-type: none"> <li>• offices</li> <li>• conference rooms</li> <li>• classrooms</li> </ul>
 0488 24	wall	PIR	27 V powered by BUS/SCS or room controllers	IP 42	45 m <sup>2</sup>	range 8 m	RJ 45	<ul style="list-style-type: none"> <li>• small offices</li> <li>• hallways</li> <li>• lobbies</li> </ul>
 0488 25	wall	PIR	27 V powered by BUS/SCS or room controllers	IP 42	30 m <sup>2</sup>	range 30 m	RJ 45	<ul style="list-style-type: none"> <li>• warehouse</li> <li>• high ceiling location</li> </ul>
 0488 30	wall	PIR	27 V powered by BUS/SCS or room controllers	IP 55	180 m <sup>2</sup>	Ø15 m	RJ 45	<ul style="list-style-type: none"> <li>• building entrance</li> <li>• warehouse</li> </ul>

PIR : Passive infrared technology, US : Ultrasonic technology, DUAL TECH : PIR and US technologies

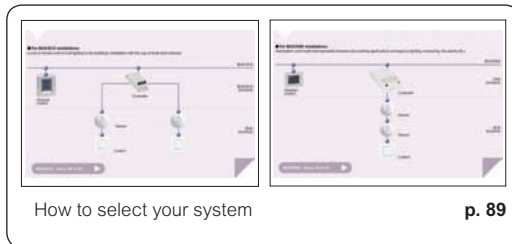

 Selection charts **p. 86 + 90-91**

BUS sensor for automatic lighting management in areas that benefit from natural light : (e.g. individual and open-plan offices, meeting rooms)  
 To combine with BUS/SCS system (p. 88 to 93) or BUS/KNX system (p. 94 to 97)  
 Presence mode : automatic on/off switching upon detection  
 Absence mode : manual switching on with push button, automatic switching off  
 Factory pre-set : time delay 15 minutes, light level threshold 500 lux for false ceiling sensors, 300 lux for flush mounted sensors  
 Precise adjustment through mobile configurators

Pack	Cat. Nos.	360° ceiling sensors (indoor)	Pack	Cat. Nos.	Special for corridors or very long areas
1	0488 20	Fixed directly to a false ceiling with mounting claws (supplied) or installed in 50 mm deep flush mounting box or in surface mounting box Cat. Nos. 0488 74/75 Connect to SCS or KNX controllers with connector Cat. No. 0488 72 - IP 20 <b>Detection field 45 m<sup>2</sup> - for private offices</b> PIR - Ø8 m - IP 20 Optimum distance between 2 sensors : 6 m Consumption 0.2 W on standby RJ 45 connection All loads 10 A - 240 V	1	0488 25	PIR front range 30 m - IP 42 With directional head Specially adapted for long narrow areas Example : corridors, very high ceiling areas or warehouses
1	0488 22	<b>Detection field 90 m<sup>2</sup> - for meeting rooms or large offices</b> Dual-tech - Ø11 m - IP 20 Optimum distance between 2 sensors : 10 m Consumption 0.5 W on standby RJ 45 connection All loads 10 A - 240 V	1	Arteor 5740 46	<b>180° switch sensors - Detection field 15 m<sup>2</sup></b> <b>Presence sensors</b> PIR - Maximum range 10 m - IP 41 ○ White ● Magnesium
1	0488 21	<b>Detection field 45 m<sup>2</sup> - for enclosed spaces with obstacles</b> Ultrasonic - Ø14 m IP 20 Optimum distance between 2 sensors : 12 m Consumption 0.5 W on standby RJ 45 connection All loads 10 A - 240 V	1	Arteor 5740 48	<b>Absence sensors</b> Dual-tech - Maximum range 10 m - IP 41 ○ White ● Magnesium
1	0488 24	<b>180° and 270° wall sensors</b> Supplied with fixing base Connect to 2 circuit controller Cat. No. 0488 50, see p. 83, by cord or RJ 45 cable or BUS/SCS cable fitted with RJ 45 connector Cat. No. 0488 72 <b>180° corner sensor (indoor) - Detection field 45 m<sup>2</sup> - for small offices</b> PIR - Maximum range 8 m - IP 42 Optimum distance between 2 sensors : 6 m Consumption 0.2 W on standby RJ 45 connection All loads 10 A - 240 V	1	0488 28	<b>Lighting measurement cell</b> Used in conjunction with detectors, it allows synchronisation of lighting measurement Mobile configurator must be used to configure the lighting cell Cat. No. 0882 30, see p. 93 Connects to BUS/SCS cable with connector Cat. No. 0488 72
1	0488 23	<b>180° corner sensor (indoor) - Detection field 90 m<sup>2</sup> - for conference rooms and large offices</b> Dual-tech - Maximum range 11 m - IP 42 With directional head Optimum distance between 2 sensors : 10 m Consumption 0.2 W on standby RJ 45 connection All loads 10 A - 240 V	1	0488 72	<b>RJ 45-BUS/SCS connectors</b> Allow controller(s) and detector(s) to be connected directly using BUS/SCS wiring by branch connection Male connector
1	0488 30	<b>270° corner sensor (outdoor) - Detection field 180 m<sup>2</sup> - for building entrances, car parks</b> PIR - Maximum range 15 m - IP 55 Front detection 10 m Lateral detection 30 m (2 x 15) Consumption 0.5 W on standby RJ 45 connection All loads 10 A - 240 V	1	0488 73	Female connector
5	0488 74		5	0488 74	<b>Surface mounting boxes</b> Used for surface mounting ceiling sensors For ceiling sensors Cat. Nos. 0488 03, 0488 07 and 0488 20
5	0488 75		5	0488 75	For ceiling sensors Cat. Nos. 0488 05/06, 0488 17, 0488 21/22 and 0488 35



5739 74



5739 02

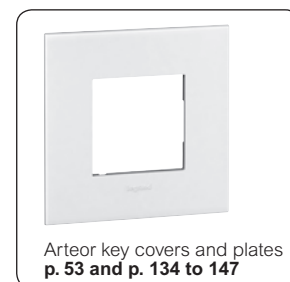

Arteor key covers and plates  
p. 53 and p. 134 to 147

Individual or centralised controls for lighting management

Supplied with BUS/SCS connector Cat. No. 0492 22 (p. 93) for connection with BUS/SCS and KNX controllers

Connection :

- to the fixed room controller via BUS/SCS cable fitted with connector Cat. No. 0488 72 (p. 87)

- directly to the BUS/SCS cable in the event of a modular control unit

Pack	Cat. Nos.	<b>Arteor "push button type" lighting control unit</b>
1	5739 87	Used to control 1 circuit <b>ON/OFF control units - 1 way</b> Used to control 2 lighting circuits ON/OFF control unit



Pack	Cat. Nos.	<b>Arteor scenario management</b>
1	5739 02	Allows several controllers to be operated 4 buttons allowing 1 scenario to be managed per button Example : lighting level adjustment, lighting control with openings ○ White ● Magnesium
1	5739 03	



Pack	Cat. Nos.	<b>Arteor "switch type" multifunctional control unit</b>
1	5739 74	For controlling a group of controllers : ON/OFF, dimming, ventilation, roller blinds "Switch type" multifunctional control unit



Pack	Cat. Nos.	<b>Remote control devices - 4 scenario controls</b>
1	0882 32	Allowing scenario to be managed Example : lighting level adjustment, lighting control with openings, in the same way as normal cut off <b>IR/RF control - 5 scenarios</b> Powered by two 1.5 V LR 03 alkaline batteries (supplied)
1	0882 33	<b>IR/RF control with screen - 16 scenarios</b> Powered by two 1.5 V LR 03 alkaline batteries (supplied)

# SELECT YOUR SYSTEM



## ■ For BUS/SCS installations

Local or remote control of all lighting in the building's installation with the use of dedicated software

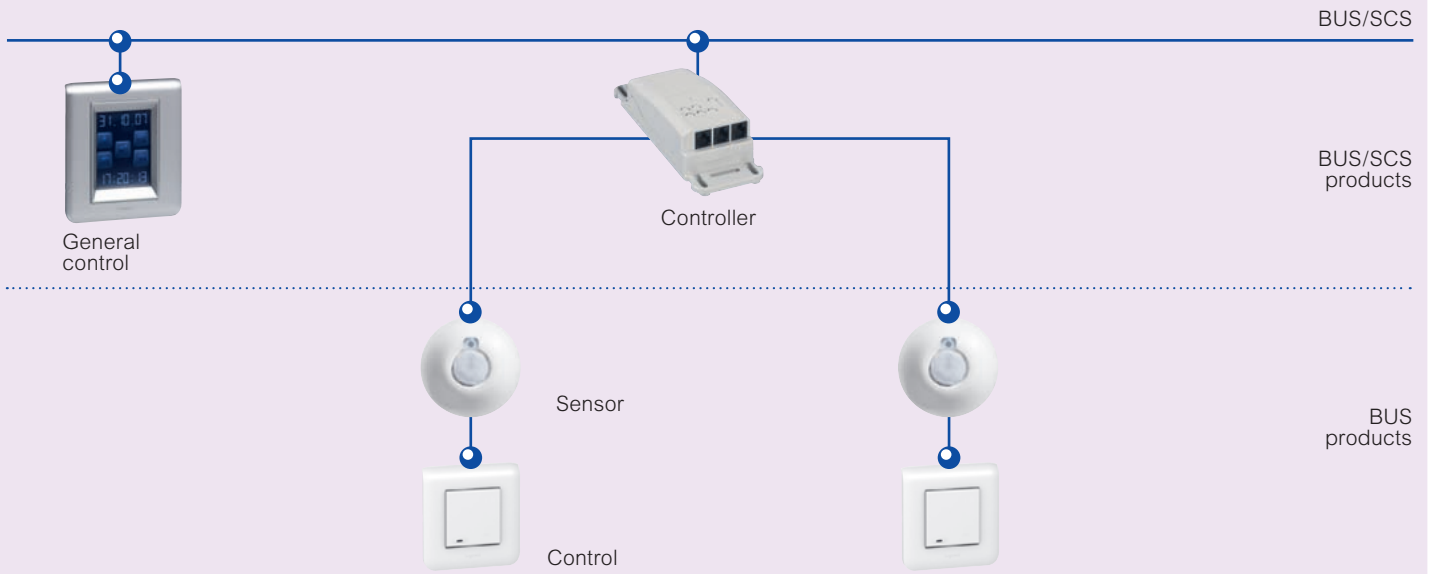

BUS/SCS : see p. 86 to 93



## ■ For BUS/KNX installations



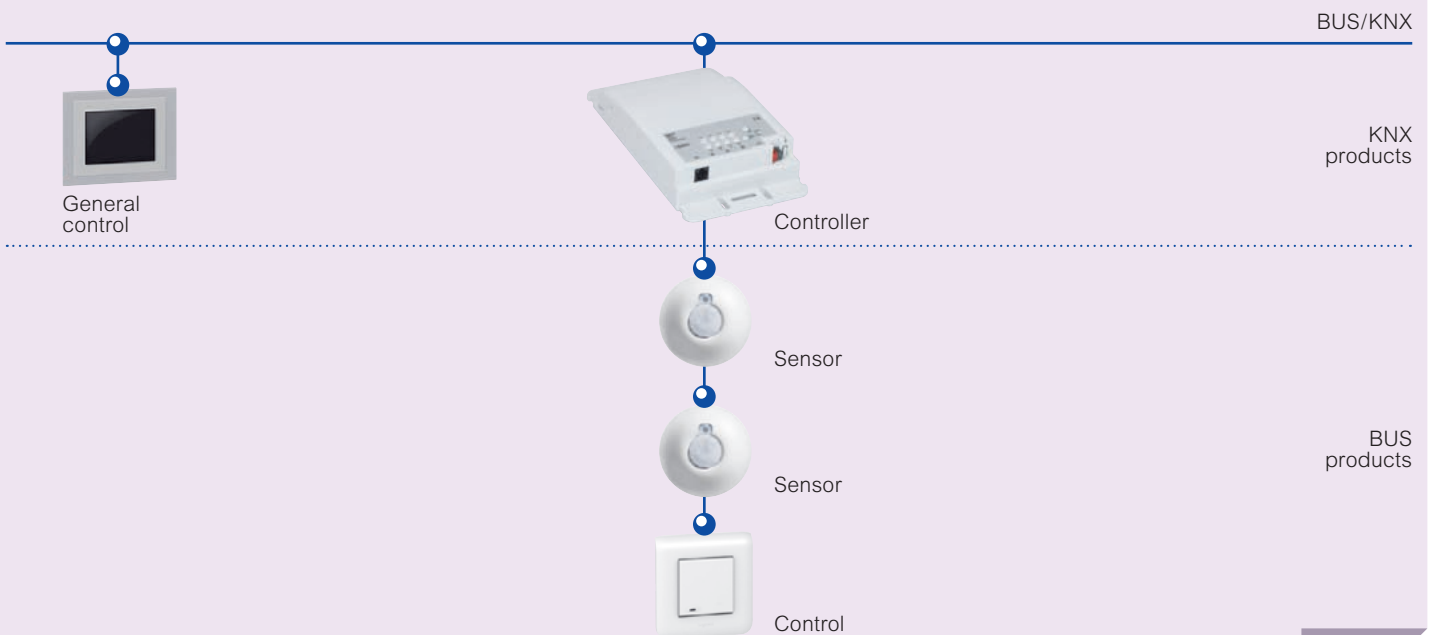



Automated control with interoperability between pre-existing applications (emergency lighting, measuring, fire alarms etc.)



BUS/KNX : see p. 94 to 97



# lighting management BUS/SCS system room controllers

Cat. Nos.	MAIN CHARACTERISTICS		TYPE OF LIGHT COMPATIBILITY							ON/OFF	Dimming	Automation
	Number of outputs	Power supply	Halogen light	ELV halogen with separate ferromagnetic or electromagnetic transformer	Fluorescent tube	Fluorescent light with separate ferromagnetic or electronic ballast	LED	Compact fluorescent light with 1-10 V ballasts	DALI Ballast	Motors		
 0488 40	1	240 V	3600 W	3600 W	1 x 1000 VA	1 x 1000 VA	1 x 500 W	1 x 1000 VA	-	-		
		100 V	1800 W	1800 VA	1 x 500 VA	1 x 500 VA	1 x 250 W	1 x 500 VA	-	-		
	 0488 41	2	240 V	3600 W	3600 W	2 x 1000 VA	2 x 1000 VA	2 x 500 W	2 x 1000 VA	-	-	
			100 V	1800 W	1800 VA	2 x 500 VA	2 x 500 VA	2 x 250 W	2 x 500 VA	-	-	
 0488 42   0488 43   0488 44   0488 45	2	240 V	3600 W	3600 W	2 x 1000 VA	2 x 1000 VA	2 x 500 W	2 x 1000 VA	-	-		
		100 V	1800 W	1800 VA	2 x 500 VA	2 x 500 VA	2 x 250 W	2 x 500 VA	-	-		
	4	240 V	3600 W	3600 W	4 x 1000 VA	4 x 1000 VA	4 x 500 W	4 x 1000 VA	-	-		
		100 V	1800 W	1800 VA	4 x 500 VA	4 x 500 VA	4 x 250 W	4 x 500 VA	-	-		
	4	240 V	-	-	-	-	-	-	4 x 32 ballasts	-		
		100 V	-	-	-	-	-	-	-	-		
	2	240 V	2000 W	2000 VA	-	-	2 x 500 W <sup>1</sup> with min. 40 W per output	-	-	-		
		100 V	1000 W	1000 VA	-	-	2 x 250 W <sup>1</sup> with min. 20 W per output	-	-	-		
 0488 47	2 lighting + 2 automation	240 V	3600 W	3600 VA	2 x 1000 W	2 x 1000 VA	2 x 500 W	2 x 1000 VA	-	500 VA		
		100 V	1800 W	1800 VA	2 x 500 W	2 x 500 VA	2 x 250 W	2 x 500 VA	-	500 VA		

1 : Compatible with most types of dimmable LED

**NEW**
**lighting management BUS/SCS system**  
**DIN controllers**

Cat. Nos.	CHARACTERISTICS			TYPE OF LIGHT COMPATIBILITY								
	Number of outputs	Number of modules	Power supply	Halogen light	ELV halogen with separate ferromagnetic or electromagnetic transformer	Fluorescent tube	Fluorescent light with separate ferromagnetic or electronic ballast	LED	Compact fluorescent light with 1-10 V ballasts	DALI Ballast	Motor	
ON/OFF	0026 00	1	4	240 V	1 x 3600 W	1 x 3600 W	1 x 1000 VA	1 x 1000 VA	1 x 500 W	-	-	
				100 V	1 x 1800 W	1 x 1800 W	1 x 500 VA	1 x 500 VA	1 x 250 W	-	-	
	0026 01	2	4	240 V	2 x 3600 W	2 x 3600 W	2 x 1000 VA	2 x 1000 VA	2 x 500 W	-	-	
				100 V	2 x 1800 W	2 x 1800 W	2 x 500 VA	2 x 500 VA	2 x 250 W	-	-	
	0026 02	4	6	240 V	4 x 3600 W	4 x 3600 W	4 x 1000 VA	4 x 1000 VA	4 x 500 W	-	-	
				100 V	4 x 1800 W	4 x 1800 W	4 x 500 VA	4 x 500 VA	4 x 250 W	-	-	
	0026 04	8	10	240 V	8 x 3600 W	8 x 3600 W	8 x 1000 VA	8 x 1000 VA	8 x 500 W	-	-	
				100 V	8 x 1800 W	8 x 1800 W	8 x 500 VA	8 x 500 VA	8 x 250 W	-	-	
	DIMMING	0026 12	4	10	240 V	-	-	-	-	-	4 x 1000 VA	-
					100 V	-	-	-	-	-	4 x 500 VA	-
		0026 21	1	6	240 V	1 x 1000 W	1 x 1000 VA	-	-	1 x 500 W <sup>1</sup>	-	-
					100 V	1 x 500 W	1 x 500 VA	-	-	1 x 250 W	-	-
0026 22		2	6	240 V	2 x 400 W	2 x 400 VA	-	-	1 x 200 W <sup>1</sup>	-	-	
				100 V	2 x 200 W	2 x 200 VA	-	-	1 x 100 W	-	-	
0026 33		8	10	240 V	-	-	-	-	-	-	8 x 16 ballasts	-
				100 V	-	-	-	-	-	-	-	-
MULTI-APPLICATION	0038 41	1	2	240 V	-	-	-	-	-	-	4 A x 1 output	
				100 V	-	-	-	-	-	-	-	
	0038 42	2	2	240 V	-	-	-	-	-	-	2 A x 2 outputs	
				100 V	-	-	-	-	-	-	-	
	0038 44	4	2	240 V	-	-	-	-	-	-	2 A x 4 outputs	
				100 V	-	-	-	-	-	-	-	

1 : Compatible with most types of dimmable LED

## lighting management BUS/SCS system room controllers

NEW



0488 42

0488 47



Selection charts p. 90-91

### Connection :

- to the sensor by cord or RJ 45 cable or BUS/SCS cable BUS/SCS to be fitted with RJ 45 connector Cat. No. 0488 72 (p. 87)
- to the BUS/SCS directly by cord or cable to be fitted with RJ 45 / BUS/SCS connector Cat. No. 0488 72 (p. 87)
- Can be controlled for each output by a sensor and/or an individual or centralised BUS/SCS control
- Configuration with controls and sensors :
  - intuitive by default - Plug and go mode
  - product customisation by touch support or by mobile configurator Cat. No. 0882 30 (p. 93) (via sensors) - Push and learn mode
  - via programming software Cat. No. 0488 80 (p. 93)
- Install on false ceiling via cable ducting

### Pack Cat. Nos. ON/OFF lighting controllers

1	0488 40	16 A on 1 output
1	0488 41	16 A on 2 outputs

### Dimming controllers

1	0488 44	<b>For DALI protocol</b> 4 outputs 16 ballasts maximum per output
1	0488 42	<b>For 1-10 V ballast</b> 2 outputs 1 000 VA maximum per output
1	0488 43	4 outputs 1 000 VA maximum per output
1	0488 45	<b>For LV and ELV halogen</b> 2 outputs 1000 W maximum per output

### Multi-application controller

1	0488 47	2 or 1-10 V dimming lighting outputs 1 blinds output 1 fan output
---	---------	-------------------------------------------------------------------------

### RJ 45 doubler

10	0488 68	Allows the number of controller inputs to be doubled
----	---------	------------------------------------------------------

## lighting management BUS/SCS system DIN controllers

NEW

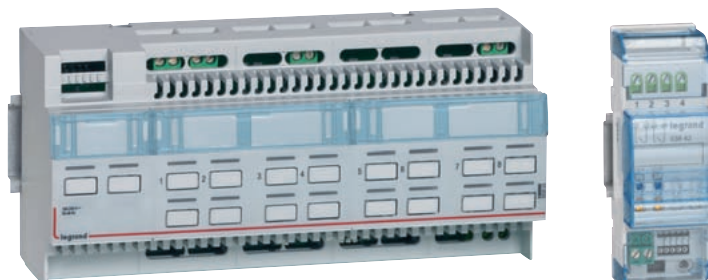

0026 33

0038 42

DIN controllers and interfaces connected to the BUS/SCS by BUS/SCS cable

Each output is independent and can be used in conjunction with a control

Configuration with controls and sensors :

- intuitive with Cat. No. 0035 70 (addressing module below)
- product customisation by touch support
- through programming software Cat. No. 0488 80 (p. 93)

### Pack Cat. Nos. ON/OFF lighting controllers

1	0026 00	1 x 16 A output 4 x 17.5 mm DIN modules
1	0026 01	2 x 16 A outputs 4 x 17.5 mm DIN modules
1	0026 02	4 x 16 A outputs 6 x 17.5 mm DIN modules
1	0026 04	8 x 16 A outputs 10 x 17.5 mm DIN modules

### Dimming controllers

1	0026 12	<b>For 1-10 V ballast</b> 4 outputs - 1 000 VA maximum per output 10 x 17.5 mm DIN modules
1	0026 21	<b>For LV and ELV halogen</b> 6 x 17.5 mm DIN modules
1	0026 22	1 output - 1 000 W maximum
1	0026 22	2 outputs - 500 W maximum per output
1	0026 33	<b>For DALI protocol</b> 10 x 17.5 mm DIN modules 8 outputs 16 ballasts maximum per output, frame steering

### Multi-application controllers

1	0038 41	N/O contact For roller blinds and motors 2 x 17.5 mm DIN modules
1	0038 42	1 x 16 A output
1	0038 44	2 x 6 A outputs 4 x 6 A outputs

### Addressing module

1	0035 70	To be used with DIN dimming controllers and ON/OFF lighting controllers for automatic or customised configuration 2 x 17.5 mm DIN modules
---	---------	----------------------------------------------------------------------------------------------------------------------------------------------

**lighting management**  
**BUS/SCS system touch screen**  
**control and DIN equipment**

**NEW**



5739 58



0035 62

**lighting management**  
**BUS/SCS system**  
**software and accessories**

**NEW**



0488 81



0882 35



0882 30

Pack	Cat. Nos.	Area manager
1	0026 45	Includes 2 functions : - manages scenario programming (for example : time management, lighting, presence) - IP interface links the BUS/SCS infrastructure and the IP network Requires power supply unit Cat. No. 0634 42 (below) For operation, requires software pack Cat. No. 0488 81 or for supervision requires Cat. No. 0488 82 (see opposite) 6 x 17.5 mm DIN modules

Pack	Cat. Nos.	Touch screen control - scenario management (Arteor)
1	5739 58	BUS/SCS multiple scenarios Allows manual or programmed control of lighting (lighting level), openings, fans and multimedia equipment. Option of timed management To be installed in flush mounting box Cat. Nos. 0892 79 or 0893 79 (p. 61) Equipped with White and Magnesium surround To be equipped with Arteor plates Cat. Nos. 5764 84 (Mirror White), 5764 83 (Mirror Black), 5764 86 (Stainless Steel), 5764 80 (Gold Brass) and 5764 87 (Woven Metal) (p. 137)

Pack	Cat. Nos.	Extension gateways
1	0035 51	Allow the BUS/SCS to communicate with other systems <b>Scenario module</b> Allows scenarios to be created through link with Arteor Cat. No. 5739 58 without a software tool
1	0035 53	<b>Wiring system - BUS/SCS</b> Used to connect traditional wiring accessories (for example : switch, timer, external sensor) 2 independent contacts 2 x 17.5 mm DIN modules
1	0035 62	<b>BUS - BUS/SCS extension</b> Used to extend a line beyond 175 products and 300 m and therefore allows product identification in the same line Requires power supply unit Cat. Nos. 0035 60/67 2 x 17.5 mm DIN modules

Pack	Cat. Nos.	Modular power supply units
1	0035 60	<b>For BUS/SCS</b> 230 V~ - 27 V= - 1.2 A 8 x 17.5 mm DIN modules
1	0035 67	230 V~ - 27 V= - 0.6 A 2 x 17.5 mm DIN modules
1	0634 42	<b>For area manager Cat. No. 0026 45</b> 220-240 V~ - 50/60 Hz - 12 V= - 1.2 A 2 x 17.5 mm DIN modules

Pack	Cat. Nos.	Software packs
1	0488 80	Pack 1 : - quoting software - product setup on AutoCad installation diagram - system configuration (addressing and product interlinking)
1	0488 81	Pack 2 : - quoting software - product setup on AutoCad installation diagram - system configuration (addressing and product interlinking) - use (installation monitoring and maintenance with optimised energy consumption in the building) Option of installing remote control on the PC desktop
1	0488 82	Pack 3 : - quoting software - product setup on AutoCad installation diagram - system configuration (addressing and product interlinking) - use (installation monitoring and maintenance with optimised energy consumption in the building) Option of installing remote control on the PC desktop - supervision (surveillance and remote control of the installation)





Pack	Cat. Nos.	BUS/SCS cables
1	0492 31	Supplied on a reel Length 100 m
1	0492 32	Length 500 m
1	0492 33	Length 200 m halogen free

Pack	Cat. Nos.	Mobile configurators
1	0882 35	All sensors are pre-set in the factory - lighting threshold : 500 lux false ceiling, 300 lux surface mounted - time delay : 15 minutes and walkthrough function activated The mobile configurators allow the pre-adjusted settings and the detection sensitivity to be readjusted
1	0882 30	Step by step programming via pre-set buttons Digital programming to the nearest decimal place using digital screen Instant programming control Allows the settings of each sensor to be displayed Option of putting adjustment settings in the memory and using them for other sensors

Pack	Cat. Nos.	BUS/SCS connector
10	0492 22	Enables the BUS/SCS to be connected to a BUS/SCS control unit Screw terminals









# lighting management BUS/KNX system room controllers

**NEW**

Cat. Nos.	MAIN CHARACTERISTICS		TYPE OF LIGHT COMPATIBILITY						
	Number of outputs	Power supply	Halogen light	ELV halogen with separate ferromagnetic or electromagnetic transformer	Fluorescent tube	Fluorescent light with separate ferromagnetic or electronic ballast	LED	Compact fluorescent light with 1-10 V ballasts	DALI Ballast
 0488 62	4	240 V	3600 W	3600 W	4 x 1000 VA	4 x 1000 VA	4 x 500 W	4 x 1000 VA	-
		100 V	1800 W	1800 VA	4 x 500 VA	4 x 500 VA	4 x 250 W	4 x 500 VA	
 0488 61	2	240 V	2000 W	2000 VA	-	-	-	-	-
		100 V	1000 W	1000 VA	-	-	-	-	
 0488 64	4	240 V	-	-	-	-	-	-	4 x 32 ballasts
		100 V	-	-	-	-	-	-	
 0488 66	8	240 V	-	-	-	-	-	-	8 x 16 ballasts
		100 V	-	-	-	-	-	-	



**NEW**
**lighting management BUS/KNX system  
DIN controllers**

Cat. Nos.	CHARACTERISTICS			TYPE OF LIGHT COMPATIBILITY									
	Outputs	Number of modules	Power supply	Halogen light	ELV halogen with separate ferromagnetic or electromagnetic transformer	Fluorescent tube	Fluorescent light with separate ferromagnetic or electronic ballast	LED	Compact fluorescent light with 1-10 V ballasts	DALI Ballast			
<b>ON/OFF</b>	 0026 00 + 0026 34	1	4	240 V	1 x 3600 W	1 x 3600 W	1 x 1000 VA	1 x 1000 VA	1 x 500 W	-	-		
				100 V	1 x 1800 W	1 x 1800 W	1 x 500 VA	1 x 500 VA	1 x 250 W	-			
	 0026 01 + 0026 34	2	4	240 V	2 x 3600 W	2 x 3600 W	2 x 1000 VA	2 x 1000 VA	2 x 500 W	-	-		
				100 V	2 x 1800 W	2 x 1800 W	2 x 500 VA	2 x 500 VA	2 x 250 W	-			
	 0026 02 + 0026 34	4	6	240 V	4 x 3600 W	4 x 3600 W	4 x 1000 VA	4 x 1000 VA	4 x 500 W	-	-		
				100 V	4 x 1800 W	4 x 1800 W	4 x 500 VA	4 x 500 VA	4 x 250 W	-			
	 0026 04 + 0026 34	8	10	240 V	8 x 3600 W	8 x 3600 W	8 x 1000 VA	8 x 1000 VA	8 x 500 W	-	-		
				100 V	8 x 1800 W	8 x 1800 W	8 x 500 VA	8 x 500 VA	8 x 250 W	-			
	<b>DIMMING</b>	 0026 35	-	-	-	-	-	-	-	-	-	64 ballasts	
		 0026 33 + 0026 34	8	10	240 V	-	-	-	-	-	-	-	8 x 16 ballasts
					100 V	-	-	-	-	-	-	-	
		 0026 12 + 0026 34	4	10	240 V	-	-	-	-	-	4 x 1000 VA	-	-
					100 V	-	-	-	-	-	4 x 500 VA	-	
		 0026 21 + 0026 34	1	6	240 V	1 x 1000 W	1 x 1000 VA	-	-	-	-	-	-
					100 V	1 x 500 W	1 x 500 VA	-	-	-	-	-	
		 0026 22 + 0026 34	2	6	240 V	2 x 400 W	2 x 400 VA	-	-	-	-	-	-
100 V	2 x 200 W				2 x 200 VA	-	-	-	-	-			

## lighting management BUS/KNX system room controllers

NEW



KNX  
KNX certified



0488 62



0488 64



Selection charts p. 90-91

Connection on BUS/KNX cable Cat. No. 0492 91 (p. 97) with connectors installed on the product  
Configuration by ETS programming tool

Pack	Cat. Nos.	BUS/KNX room controllers for dimming
1	0488 62	Can be controlled for each output by a sensor and/or an individual BUS control Connect to the sensor by cord or RJ 45 cable or BUS/SCS cable to be fitted with RJ 45 connector Cat. No. 0488 72 (p. 87) <b>For 1-10 V ballast</b> 4 outputs 1 000 VA maximum per output Can also provide "ON/OFF" control of 4 circuits
1	0488 61	<b>For LV and ELV</b> 2 outputs 1 000 W maximum per output
1	0488 64	<b>For DALI protocol</b> 4 outputs 32 ballasts maximum per output
1	0488 66	8 outputs 16 ballasts maximum per output

## lighting management BUS/KNX system DIN controllers

NEW



0026 35

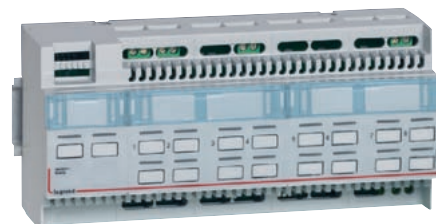

0026 33

Connection on BUS/KNX cable Cat. No. 0492 91 (p. 97) with connectors installed on the product  
Configuration by ETS programming tool

Pack	Cat. Nos.	BUS/KNX DIN controller for dimming
1	0026 35	<b>For DALI protocol</b> Used to control 64 ballasts individually Supplied with DALI addressing tool 6 x 17.5 mm DIN modules
1	0026 34	<b>KNX DIN controllers</b> <b>KNX multi-channel DIN controller</b> For use with BUS/SCS DIN controllers (p. 92), BUS controls and sensors (p. 87-88) For connecting these products to the BUS/KNX system Supplied with power supply unit Cat. No. 0035 67 (p. 62) 2 + 2 x 17.5 mm DIN modules
1	0026 00	<b>ON/OFF lighting controllers</b> 1 x 16 A 4 x 17.5 mm DIN modules
1	0026 01	2 x 16 A 4 x 17.5 mm DIN modules
1	0026 02	4 x 16 A 6 x 17.5 mm DIN modules
1	0026 04	8 x 16 A 10 x 17.5 mm DIN modules
1	0026 33	<b>Dimming controller for DALI protocol</b> 10 x 17.5 mm DIN modules 8 outputs 16 ballasts maximum per output, frame steering
1	0026 12	<b>Dimming controller for 1-10 V ballast</b> 4 outputs - 1 000 VA maximum per output 10 x 17.5 mm DIN modules
1	0026 21	<b>Dimming controllers for LV and ELV halogen</b> 6 x 17.5 mm DIN modules 1 output - 1 000 W maximum
1	0026 22	2 outputs - 500 W maximum per output

**lighting management**  
**BUS/KNX system**  
**touch screen control and interface**

**NEW**



0488 84



0035 43



0035 44

Pack	Cat. Nos.	
1	0488 84	<b>5-7" touch screen control - scenario management</b> BUS/KNX multiple scenarios For connection to BUS/KNX cable Cat. No. 0492 91 (below) with the connectors installed on the product Allows several BUS/KNX controllers to be operated Allows manual or programmed control of lighting (lighting level), openings, fans and multimedia equipment Manages scenario programming (for example : time management, lighting, presence) Supplied complete with aluminium finishing plate, support and flush mounting box
1	0035 47	<b>BUS/KNX - USB interface</b> Used to connect a PC to the BUS/KNX system via the USB port 1 x 17.5 mm DIN module
1	0035 16	<b>KNX/BUS coupling unit</b> For extending the installation beyond 64 KNX units To use with Cat. No. 0035 12 2 modules
1	0035 12	<b>Modular power supply unit</b> 230 V~ 29 V= - 320 mA 4 modules
1	0492 91	<b>BUS/KNX cable</b> Length 500 m
1	0035 43	<b>IP communication module</b> BUS/KNX - IP gateway 2 functions : - The IP interface provides the link between the BUS/KNX infrastructure and the IP network to set the parameters remotely with ETS tool - Web communication interface to activate scenarios remotely via a dedicated web page Enables off-site operation 4 x 17.5 mm DIN modules
1	0035 44	<b>Building manager</b> Used together with Legrand and third party systems, this building manager enables : - Processing and combination of the data from these systems (KNX, Modbus and Bacnet protocols) - Automatic control by time programming, load shedding, management of conditions, etc. - Alarm monitoring and surveillance - All these data to be available for an overall supervision system

**lighting management BUS/KNX system**  
**installation supervision**

■ **Operating principle of the IP communication module Cat. No. 0035 43**

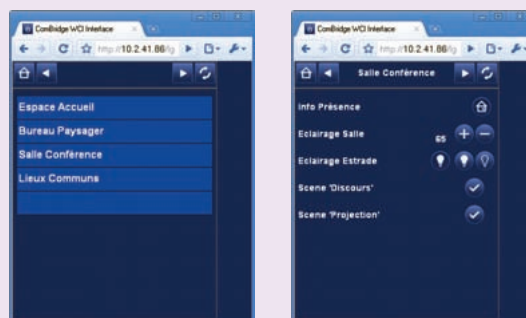

■ **Operating principle of the supervision gateway Cat. No. 0035 44**

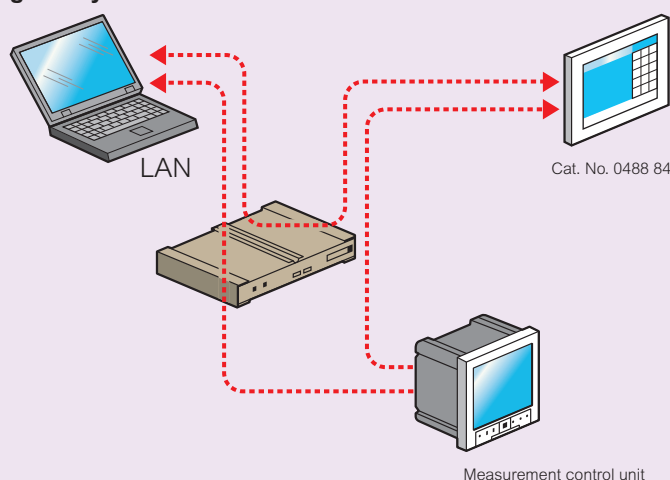



5738 36







5738 49





5738 62

Radio/ZigBee® 2-4 GHz, signal range 100 m

Operates in association with Radio/ZigBee® products - with BUS/SCS installation using BUS/SCS interface - Radio ZigBee® Cat. No. 0488 32 (see below)  
To be fitted with Arteor plates (p. 134-147)

Pack	Cat. Nos.	Lighting remote control transmitters (Arteor)
1	5738 34	<p>Powered by 3V CR 2032 lithium batteries (supplied) Supplied with support, directly mounted on the wall without flush mounting box, 2 modules</p> <p><b>For 1 circuit switch controllers</b> Allows 1 Radio/ZigBee® product to be controlled (for example : 1 controller)</p> <p>○ White ● Black</p> 
1	5738 35	
1	5738 36	<p><b>For 2 circuit switch controllers</b> Allows 2 Radio/ZigBee® products to be controlled (for example : 1 controller and a 240 V~ control unit)</p> <p>○ White ● Black</p> 
1	5738 37	
1	5738 38	<p><b>For dimmer controllers</b> Allows 1 Radio/ZigBee® DALI, 1-10 V, LV and ELV halogen control unit to be controlled</p> <p>○ White ● Black</p> 
1	5738 39	
1	5738 42	<p><b>For roller blind controllers</b></p> <p>○ White ● Black</p> 
1	5738 43	
1	5738 48	<p><b>4-scenario controls</b> Allow 4 scenarios to be managed using 4 buttons For example : lighting level adjustment, lighting control with openings...as well as normal cut off</p> <p>○ White ● Black</p> 
1	5738 49	

Pack	Cat. Nos.	Lighting controllers/receivers (switches) 100/240 VA (Arteor)
1	5738 22	<p>Transmitter/receiver switches Installation in flush mounting box, depth 50 mm recommended 2 modules</p> <p><b>ON/OFF switches - 1 way</b> Switch without neutral - 2500 W - 1 circuit With LED to see output control status Max. load : 1 x 2500 W</p> <p>○ White ● Black</p> 
1	5738 23	
1	5738 24	<p><b>ON/OFF switches - 2 ways</b> Switch with neutral - 2 x 1000 W - 2 circuits With LED to see output control status Max. load : 2 x 1000 W</p> <p>○ White ● Black</p> 
1	5738 25	
1	5738 40	<p><b>Roller blind controllers/receivers 100/240 VA (Arteor)</b></p> <p>○ White ● Black</p> 
1	5738 41	
1	5738 62	<p><b>ON/OFF lighting room controller</b></p> <p>1 output - 2 500 W</p>
1	5738 66	<p><b>Dimming room controllers</b></p> <p><b>For 1-10 V ballast</b> 1 output - 500 VA</p>
1	5738 64	<p><b>For LV and ELV halogen</b> 1 output - 600 W</p>
1	0488 32	<p><b>BUS/SCS interface - Radio/ZigBee®</b></p> <p>Used to link a BUS/SCS installation and an additional Radio/ZigBee® installation BUS/SCS interface - Radio/ZigBee® Install in false ceiling</p>
1	0488 37	<p><b>Repeater</b></p> <p>Used to increase the receiving distance from the radio signal Power supply 240 V~</p>



# lighting management Radio/ZigBee® sensors and remote control devices

# lighting management Radio/ZigBee® sensors and remote control devices



0488 14



0882 32



0882 33

Pack	Cat. Nos.	230 V ~ sensors
1	0488 35	<p>Recommended fixing height : 2-50 m</p> <p><b>360° detection field 90 m<sup>2</sup>- for working areas</b>                      Fixed directly to a false ceiling with mounting claws (supplied) or installed in 50 mm deep flush mounting box or in surface mounting box Cat. No. 0488 75 (p. 83)</p> <p>☀️ Dual-tech - Ø11 m</p> <p>Optimum distance between 2 sensors : 10 m</p> <p>Allows accurate presence detection as soon as the signal given by the sensor is interrupted (for example : hands movement)</p>
1	0488 14	<p><b>270° detection field 180 m<sup>2</sup>- for passage areas</b>                      Surface mounting sensor</p> <p>☀️ PIR IP 55</p> <p>Front detection 10 m                      Lateral detection 30 m (2 x 15)</p> <p>Detection specially adapted for building entrance, warehouses, car parks</p>
1	0488 31	<p><b>Battery-powered sensor</b></p> <p>Powered by two 1-5 V LR 03 alkaline batteries (supplied)</p> <p>Recommended fixing height : 2-50 m</p> <p><b>270° detection field 180 m<sup>2</sup>- for passage areas</b>                      Surface mounting sensor</p> <p>☀️ PIR IP 55</p> <p>Front detection 10 m                      Lateral detection 30 m (2 x 15)</p> <p>Detection specially adapted for building entrance, warehouses, car parks</p>
1	0882 32	<p><b>Remote control devices - 4 scenario controls</b></p> <p>Allowing scenario to be managed                      Example : lighting level adjustment, lighting control with openings... in the same way as normal cut off</p> <p><b>IR/RF control - 5 scenarios</b>                      Powered by two 1-5 V LR 03 alkaline batteries (supplied)</p>
1	0882 33	<p><b>IR/RF control with screen - 16 scenarios</b>                      Powered by two 1-5 V LR 03 alkaline batteries (supplied)</p>

## ■ No 1 : also using a BUS/SCS infrastructure

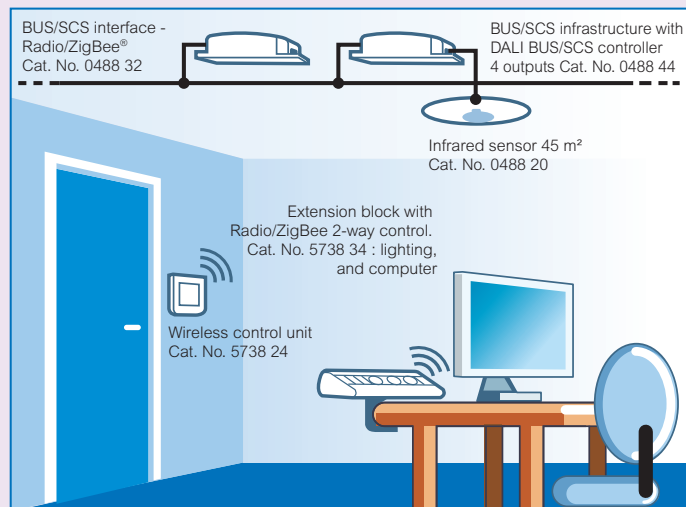

Where an office is fitted out completely in glass and the BUS/SCS cannot drop vertically, a wireless Radio/ZigBee® control unit can be installed at the door. At the same time in the extension block, a 230 V Radio/ZigBee® control unit will allow office lighting to be controlled and will allow this to be switched on and off from the PC

## ■ No 2 : using only Radio/ZigBee®

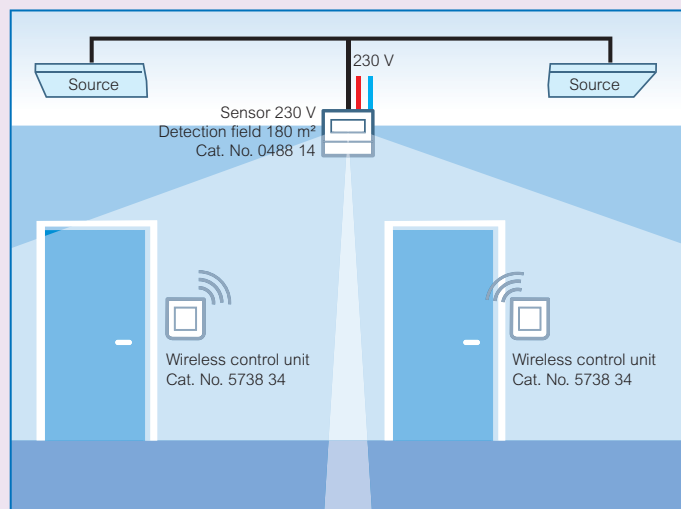

The new thermal regulation recommendations are that a manual on-switch and an automatic cut-off will provide an even bigger saving (55%)  
 In a building renovation for example, if a large area is fitted with self-contained presence sensors but the vertical connection cannot be made with its control points, Radio/ZigBee® wireless control units will be installed



Legrand's building manager viewer provides real time status and management information for lighting control and other building systems putting the user in control of their energy use.



- Multi-system: automated control
- Simple scenario control of the systems
- Display of alarms
- Time programming

**building management**  
active building management

**NEW**



0490 04



0035 44

Pack	Cat. Nos.	Building manager viewer
		<p>Software providing display, analysis and alarms for small service sector projects :</p> <ul style="list-style-type: none"> <li>- Display of the status of the connected systems</li> <li>- Simple scenario control of the systems</li> <li>- Display of alarms</li> <li>- Time programming</li> </ul> <p>For permanent installation on a dedicated PC Integrated configuration wizard for easy creation of the project and the display screens : Legrand solutions pre-programmed (lighting management, emergency lighting, power measurement, fire alarms) When used with the building manager controller Cat. No. 0035 44, provides total building management</p>
1	0490 00	Up to 100 points
1	0490 04	Up to 2000 points
1	0035 44	<p><b>Building manager controller</b></p> <p>Automatic control system dedicated to automated control in service sector buildings requiring interoperability between the various connected systems :</p> <ul style="list-style-type: none"> <li>- Legrand solutions : lighting management, emergency lighting, power measurement, fire alarms</li> <li>- Other solutions : HVAC, etc.</li> <li>• Performs the following : <ul style="list-style-type: none"> <li>- Collection of data from the various systems : KNX IP, MODBUS IP, BACNET IP, SCS IP</li> <li>- Programming of scripts (with algorithm), alarms and data logging</li> <li>- Exchanges of collected data between systems (example : display of the measured power circuit consumption values on digital screen)</li> <li>- Inclusion of HVAC systems (air conditioning, heating)</li> <li>- Sending emails for alarms</li> </ul> </li> <li>• For installation in the VDI cabinet with dedicated patching of the various application systems</li> <li>• Can be used with the building manager viewer Cat. No. 0490 00 or 0490 04 to display the installation</li> <li>• Operates with : <ul style="list-style-type: none"> <li>- The BUS/KNX lighting offer, with the KNX/IP converter Cat. No. 0035 43 (p. 97)</li> <li>- The BUS/SCS lighting offer with the zone controller Cat. No. 0026 45 (p. 93)</li> <li>- The BUS/SCS actimetry offer with the zone controller Cat. No. 0026 45 (p. 93)</li> </ul> </li> </ul>

# building management

## active building management

### ■ BUS/KNX active building management with several Legrand or other systems



**1st example :** Active building management with the building manager viewer Cat. No. 0490 00 or 0490 04 for display, analysis and alarms



**2nd example :** Active building management with the building manager viewer Cat. No. 0490 00 or 0490 04 + building manager controller Cat. No. 0035 44 for interoperability between the various connected systems :

- Legrand solutions : lighting management, emergency lighting, power measurement, fire alarms
- Other solutions : HVAC, etc.

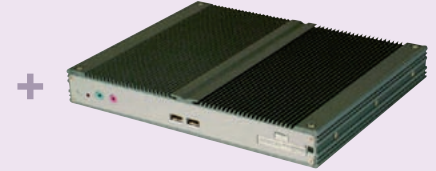

### ■ Example : Lighting management + emergency lighting + power measurement + fire alarm

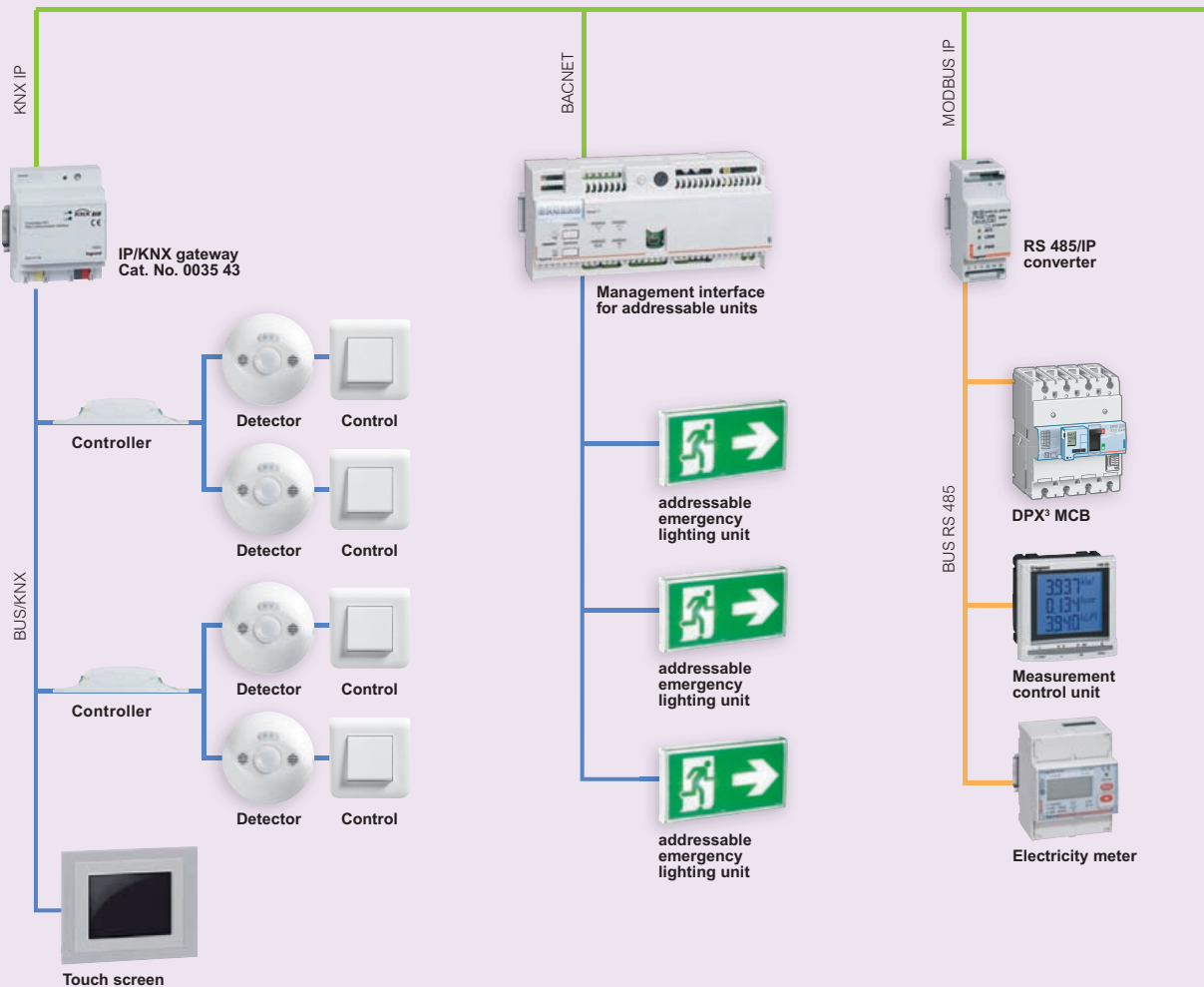

# Wiring accessories

## Arteor™



**P. 104**  
Introduction to Arteor™ wiring accessories

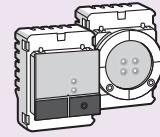

**P. 114**  
Electronic switches

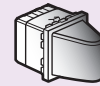

**P. 119**  
Lighting control and visual indication

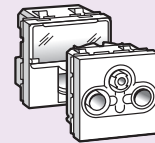

**P. 128**  
Television, telephone, data sockets and adaptors

## Synergy®

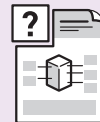

**P. 148**  
Introduction to Synergy® wiring accessories



**P. 176**  
Traditional wiring accessories

## Clipper and Electrak®



**P. 196**  
Introduction to Clipper wiring accessories

## Plexo weatherproof



**P. 201**  
IP 66 surface mounting weatherproof switches

## Lighting



**P. 204**  
Ceiling switches

## NEW IN 2012



**Arteor™**  
Key card switches  
RFID (radio frequency identification)  
**(p. 122)**



**Arteor™**  
USB chargers  
**(p. 124)**



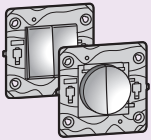

**P. 108**  
Monobloc  
mechanical  
switches and  
triple pole switch

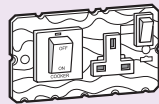

**P. 109**  
Modular DP  
switches, cooker  
control unit and  
shaver sockets

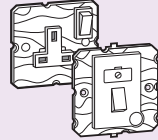

**P. 110**  
Modular socket  
outlets and  
fused connection  
units

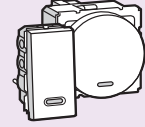

**P. 111**  
Mechanical  
switches and  
push buttons

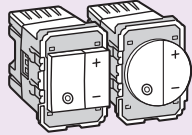

**P. 115**  
Dimmers

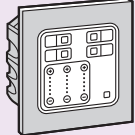

**P. 116**  
Lighting  
environment  
controller



**P. 117**  
Loads  
selection chart

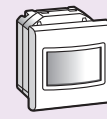

**P. 118**  
Automatic  
switches

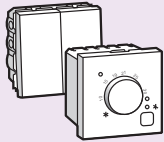

**P. 120**  
Ventilation,  
heating and roller  
blind control and  
curtain control

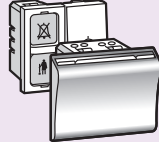

**P. 121**  
Hotel  
equipment

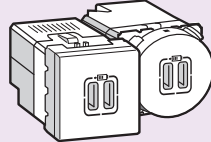

**P. 124** NEW  
USB  
chargers

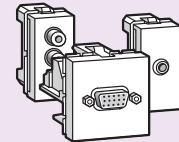

**P. 126**  
Data, audio  
and video  
sockets

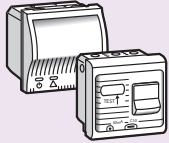

**P. 130**  
Detectors,  
RCBO and  
fuse carriers

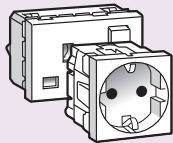

**P. 131**  
British and  
International  
standard  
socket outlets

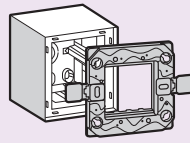

**P. 133**  
Support  
frames and  
back boxes

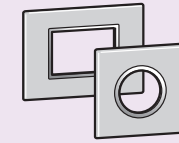

**P. 134**  
Plates



**P. 152**  
Function  
and finish  
selection  
charts

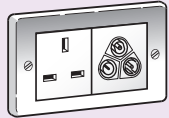

**P. 158**  
Synergy®  
carrier plates  
for Arteor™  
modules

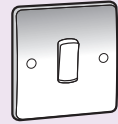

**P. 159**  
White  
wiring  
accessories



**P. 170**  
Modern  
wiring  
accessories



**P. 182**  
MEIGaN  
sockets

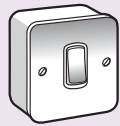

**P. 183**  
Metalclad  
wiring  
accessories

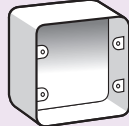

**P. 187**  
Flush and  
surface  
mounting  
back boxes

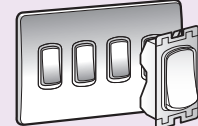

**P. 190**  
Grid system -  
modules and  
front plates



**P. 197**  
Clipper  
large rocker  
switches

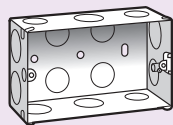

**P. 197**  
Flush mounting  
steel back boxes

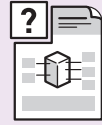

**P. 198** NEW  
Introduction  
to Electrak®  
wiring  
accessories

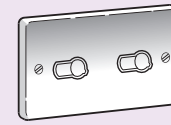

**P. 199** NEW  
Electrak®  
wiring  
accessories

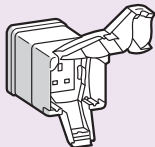

**P. 201**  
IP 66  
surface mounting  
weatherproof  
sockets

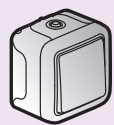

**P. 202**  
IP 55  
surface mounting  
weatherproof  
switches

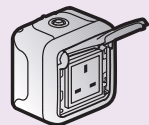

**P. 202**  
IP 55  
surface mounting  
weatherproof  
sockets

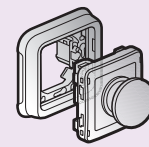

**P. 202**  
IP 55  
surface and flush  
mounting modular  
mechanisms



**P. 205**  
Safety  
lampholders  
and pendant  
sets

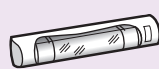

**P. 206**  
Bathroom  
lighting

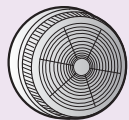

**P. 207**  
Utility weatherproof  
bulkhead lighting



**Synergy®**  
Plates for standard  
euro modules  
(available May 2013)  
**(p. 166)**



**Electrak®**  
Non standard  
unswitched socket  
outlets  
**(p. 199)**

# Complete solutions from the world specialist

With 19% of the global market, Legrand is the clear leader in wiring accessories. From simple switches and sockets, to flexible grid systems and building automation, Legrand offers a full range of standard and bespoke solutions to cater for any installation.



## ARTEOR™

Arteor marries supreme style (in a wide choice of finishes and materials), with a vast selection of functions - from a single switch to fully integrated building automation systems.



## SYNERGY®

Synergy offers modern and traditional variations with high quality components... together with countless features to make the installer's life easier.



## GRID AND MODULAR OPTIONS

Synergy grid allows you to create multi-function solutions in a single plate. Integrating Arteor function modules with Synergy plates extends your options even further.



## EVEN GREATER CHOICE

Whatever the weather Plexo IP 55 and IP 66 ranges are ideal for both residential and commercial installations while our Clipper, MEIGaN and bespoke solutions meet the needs of specialist applications.

# ARTEOR™

the ultimate  
choice

Versatility, style and functionality make Arteor the innovative answer to the increasingly complex demands of modern buildings.

Much more than just a wiring accessory, Arteor is the ideal choice for any residential or commercial project.

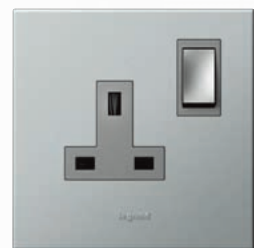

legrand

legrand  
www.legrand.com

## FROM A SINGLE SWITCH TO FULL BUILDING AUTOMATION

Arteor extends from wiring accessories, through innovative radio automation options, up to fully networked building automation systems based on BUS/SCS technology, which can also be integrated into third party solutions.

While similar in design to the standalone accessories, Arteor automation devices provide a greater range of technological features, from lighting, heating and blind automation to full scenario control (see p. 50 - 67).

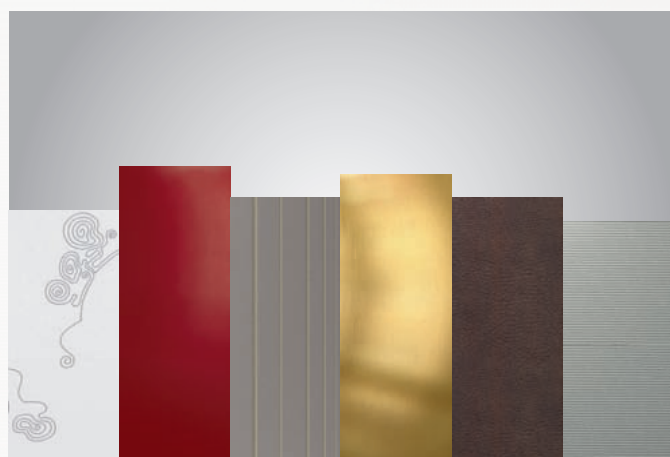

A selection of finishes available in the Arteor range

## PERFECTLY FINISHED INSTALLATIONS... EVERY TIME

From the simplicity of white moulded to the sophisticated style of woven steel, Arteor offers an array of stylish finishes that flow from its wiring accessories range through to automation devices.

With a complete range of functions and the choice of round or square rockers and modules in white or magnesium, Arteor offers designers and end users endless options in terms of style and functionality.



ARTEOR™... FLOW OF ENERGIES

# Arteor™ monobloc

mechanical switches, triple pole switch



5720 39



5725 45



5720 61



5731 74

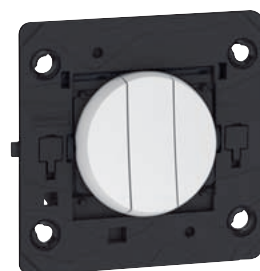

5730 93

Plates selection charts **p. 134-137**

Mechanisms supplied complete with incorporated support frames and rocker plates  
 Rocker plates in white or magnesium, square or round versions  
 Suitable for 25 mm 1 gang boxes  
 To be equipped with plates (p. 134-147)

### Pack Cat. Nos. Switches - square version

Pack	Cat. Nos.		Description
	White	Magnesium	
10	5720 39	5725 39	<b>10 AX - 250 V~</b> 1 gang intermediate switch 
10	5720 12	5725 12	<b>20 AX - 250 V~</b> 2 way - 1 gang 
10	5720 45	5725 45	2 way - 2 gang 
10	5720 61	5725 61	2 way - 3 gang 

### Pack Cat. Nos. Switches - round version

Pack	Cat. Nos.		Description
	White	Magnesium	
10	5730 64	5731 64	<b>10 AX - 250 V~</b> 1 gang intermediate switch 
10	5730 29	5731 29	<b>20 AX - 250 V~</b> 2 way - 1 gang 
10	5730 74	5731 74	2 way - 2 gang 
10	5730 93	5731 93	2 way - 3 gang 

### Triple pole switch

Pack	Cat. Nos.		Description
	White	Magnesium	
5	5720 58	5725 58	Monobloc mechanism supplied with incorporated support frame To be equipped with 2 module plate (p. 134-147) Suitable for 25 mm 1 gang box 

## Arteor™ monobloc

### double pole switches, cooker control unit



5725 80

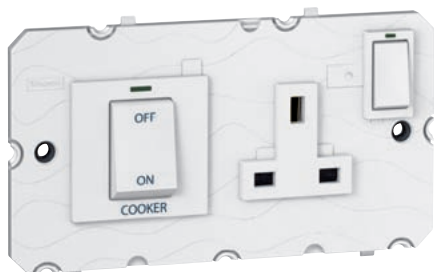

5720 88

## Arteor™ monobloc

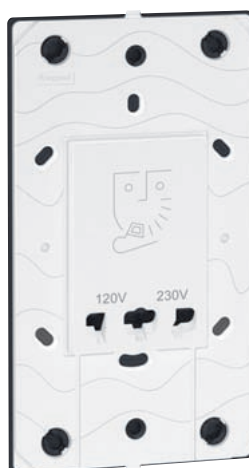

### shaver sockets



5721 53

Plates selection charts **p. 134-137**

Mechanisms supplied with white or magnesium interiors  
To be equipped with plates (p. 134-147)

Pack	Cat. Nos.		<b>Double pole switches - 250 V~</b>
5	White 5720 80	Magnesium 5725 80	<p>Conform to EN 60669-1 : 2000 Captive terminal screws Installation in flush mounting box min. depth 48 mm</p> <p><b>45 A - 250 V~</b></p> <p>Double pole switch with red indicator, indicator supplied 2 gang Use BS plate 2 gang - 3 modules</p> 
5	5720 87	5725 87	<p>Double pole switch with red indicator, indicator supplied 1 gang Use BS plate 1 gang - 2 modules</p> 

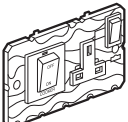
Pack	Cat. Nos.	<b>Cooker control unit - 250 V~</b>
5	White 5720 88	<p>Conform to BS 4177 : 1992 Use special plate (p. 138)</p> <p>45 A double pole switch with indicator + 13 A double pole switched socket outlet with indicator</p> 

Plates selection charts **p. 134-137**

Mechanisms supplied with white or magnesium interiors  
To be equipped with plates (p. 134-147)

Pack	Cat. Nos.		<b>Shaver sockets</b>
1	White 5721 53	Magnesium 5726 53	<p>Conform to BS EN 61558-2-5. IP 24 For use with European, British, American, Australian 2-pin plugs Screwless live and neutral terminals Double wound isolating transformer Automatic self-resetting overload feature Plug insertion operates micro-switch which energises transformer To be equipped with BS 2 gang - 3 module plates (p. 134-147) For flush mounting boxes, use BS 2 gang box depth 48 mm Power supply : 230 V - 50/60 Hz 3 modules 22.5 x 45 mm</p> <p>230 V / 120-230 V With earth connector</p> 

# Arteor™ monobloc

socket outlets, cable outlets and blanking cover plates



5726 43

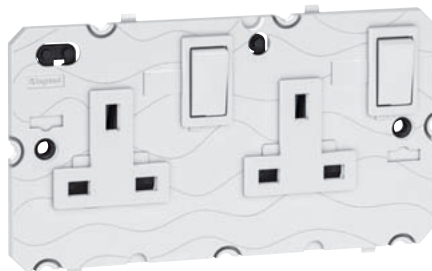

5721 49



5726 50



5751 31

Plates selection charts **p. 134-137**

Mechanisms supplied with white or magnesium interiors  
To be equipped with plates (p. 134-147)

Pack	Cat. Nos.		<b>Single pole socket outlets 13 A - 250 V~</b> Shuttered for child safety ASTA licence Use special plates (p. 134-147) <b>13 A - 1 gang</b> Conform to BS 1363 : Part 2 2P + E - switched 2P + E - switched + LED <b>13 A - 2 gang</b> Conform to BS 1363 : Part 2 2P + E - switched 2P + E - switched + LED
	White	Magnesium	
10	5721 43	5726 43	
10	5721 44	5726 44	
5	5721 45	5726 45	
5	5721 46	5726 46	

Pack	Cat. Nos.		<b>Fused connection units</b> Double pole fused 13 A (fuse supplied) Flex outlet knockout and cord grip Captive fuse carrier (padlockable) Captive terminal screws Use special plates (p. 134-147) Conform to BS 1363 : Part 4
	White	Magnesium	
5	5721 50	5726 50	 Switched
5	5721 51	5726 51	 Switched + LED
10	5721 57	5726 57	 Unswitched

Pack	Cat. Nos.		<b>Double pole socket outlets - 250 V~</b> Shuttered for child safety Use special plates (p. 134-147) <b>5 A - 1 gang</b> Conform to BS 546 2P + E - switched <b>13 A - 1 gang</b> Conform to BS 1363 : Part 2 ASTA licence 2P + E - switched <b>13 A - 2 gang</b> Conform to BS 1363 : Part 2 ASTA licence 2P + E - switched twin earth
	White	Magnesium	
10	5721 40	5726 40	
5	5721 47	5726 47	
5	5721 49	5726 49	
5	5721 41		

Pack	Cat. Nos.	<b>Cable outlet</b> Square version mechanisms 45 A cable outlet - BS 1 gang Supplied with white cover plate For flush mounting back box min. depth 45 mm
	White	
5	5723 21	

<b>Blanking cover plates</b>		
<b>For 1 gang box</b>		
5	5751 30	○ White
5	5751 31	● Pearl Alu
5	5751 32	● Graphite
<b>For 2 gang box</b>		
5	5751 40	○ White
5	5751 41	● Pearl Alu
5	5751 42	● Graphite



# Arteor™ mechanical switches

## square version



5724 50

5724 50  
back view

5725 36



5725 11



5720 43

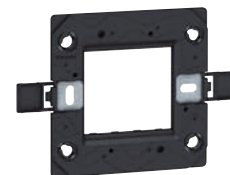

Support frames and plates



p. 133-147



Support frames and plates selection charts p. 134-137

Mechanisms supplied with white, magnesium or red square rocker plates  
To be equipped with support frames (p. 133) and plates (p. 134-147)

Pack	Cat. Nos.		Switches 10 AX - 250 V~
			<b>Single module mechanisms</b> 1 module 22.5 x 45 mm
10	White 5720 05	Magnesium 5725 05	2 way switch
5	5720 08	5725 08	Intermediate switch
10	5720 06	5725 06	2 way switch with indicator To be equipped with LED (p. 119)
10	Red 5724 50		1 way switch red rocker plate
			<b>Two module mechanisms</b> 2 modules 22.5 x 45 mm
10	White 5720 35	Magnesium 5725 35	2 way switch
10	5720 38	5725 38	Intermediate switch
5	5720 36	5725 36	2 way switch with indicator To be equipped with LED (p. 119)
5	5720 37	5725 37	2 way switch with indicator and label holder To be equipped with LED (p. 119)
1015	5720 40	5725 40	Double pole switch

Pack	Cat. Nos.		Switches 20 AX - 250 V~
			<b>Single module mechanisms</b> 1 module 22.5 x 45 mm
10	White 5720 10	Magnesium 5725 10	2 way switch
1015	5720 11	5725 11	2 way switch with indicator To be equipped with LED (p. 119)
5	5720 13	5725 13	1 way double pole switch
5	5720 14	5725 14	1 way double pole switch with indicator - Red LED supplied
5	Red 5724 51		Double pole switch red rocker plate
			<b>Two module mechanisms</b> 2 modules 22.5 x 45 mm
1015	White 5720 42	Magnesium 5725 42	2 way switch with indicator To be equipped with LED (p. 119)
10	5720 43	5725 43	1 way switch - 3 gang
10	5720 44	5725 44	2 x 2 way switch + 1 way switch 3 gang
10	5720 46	5725 46	1 way - double pole switch
10	5720 48	5725 48	2 way - double pole switch
10	5720 47	5725 47	1 way - double pole switch with indicator - Red LED supplied
10	5720 49	5725 49	1 way - double pole switch with indicator and "WATER HEATER" marking - Red LED supplied

**45 A double pole switches, cooker units** (p. 109)

# Arteor™ mechanical switches

## round version



5730 61



5731 23



5731 24



5731 25



5731 26



5731 27



5731 28



5730 72



Support frames and plates selection charts **p. 134-137**

Mechanisms supplied with white or magnesium round rocker plates  
To be equipped with support frames (p. 133) and plates (p. 134-147)

Pack	Cat. Nos.		Switches 10 AX - 250 V~
			<b>Two module mechanisms</b>
10	White 5730 61	Magnesium 5731 61	2 modules 22.5 x 45 mm 2 way switch 
10 15	5730 63	5731 63	Intermediate switch 

Pack	Cat. Nos.		Switches 20 AX - 250 V~
			<b>Single module mechanisms</b>
10	White 5730 23	Magnesium 5731 23	1 module 22.5 x 45 mm 2 way switch - left module 
10	5730 24	5731 24	2 way switch - middle module 
10	5730 25	5731 25	2 way switch - right module 
5	5730 26	5731 26	2 way switch with indicator left module To be equipped with LED (p. 119) 
5	5730 27	5731 27	2 way switch with indicator middle module To be equipped with LED (p. 119) 
5	5730 28	5731 28	2 way switch with indicator right module To be equipped with LED (p. 119) 
5	5730 30	5731 30	Double pole switch - left module 
5	5730 31	5731 31	Double pole switch - right module 

Pack	Cat. Nos.		Switches 20 AX - 250 V~ (continued)
			<b>Two module mechanisms</b>
5	White 5730 71	Magnesium 5731 71	2 modules 22.5 x 45 mm 2 way switch with indicator To be equipped with LED (p. 119) 
10 15	5730 72	5731 72	1 way switch - 3 gang 
10 15	5730 73	5731 73	2 x 2 way switch + 1 way switch - 3 gang 
10	5730 75	5731 75	1 way - double pole switch 
10	5730 76	5731 76	1 way - double pole switch with indicator - Red LED supplied 
10	5730 78	5731 78	1 way - double pole switch with indicator and "WATER HEATER" marking - Red LED supplied 

## Arteor™ push buttons square version



## Arteor™ push buttons round version

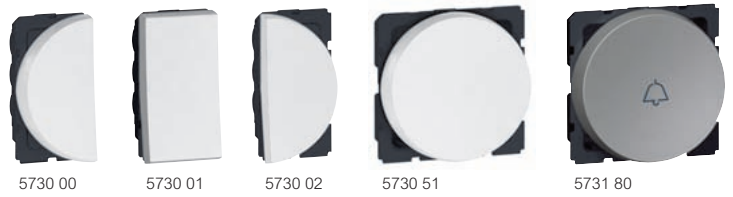

Support frames and plates selection charts **p. 134-137**

Mechanisms supplied with white or magnesium square rocker plates  
To be equipped with support frames (p. 133) and plates (p. 134-147)

Pack	Cat. Nos.		<b>Push buttons 6 A - 250 V~</b>
	White	Magnesium	
10   15	5720 01	5725 01	<b>Single module mechanisms</b> 1 module 22.5 x 45 mm 2 way push button
10	5720 02	5725 02	2 way push button with locator Equipped with blue LED
10   15	5720 31	5725 31	<b>Two module mechanisms</b> 2 modules 22.5 x 45 mm 2 way push button
5	5720 56	5725 56	1 way push button with bell symbol

Support frames and plates selection charts **p. 134-137**

Mechanisms supplied with white or magnesium round rocker plates  
To be equipped with support frames (p. 133) and plates (p. 134-147)

Pack	Cat. Nos.		<b>Push buttons 6 A - 250 V~</b>
	White	Magnesium	
10	5730 00	5731 00	<b>Single module mechanisms</b> 1 module 22.5 x 45 mm 1 way push button - left module
10	5730 01	5731 01	1 way push button - middle module
10	5730 02	5731 02	1 way push button - right module
5	5730 51	5731 51	<b>Two module mechanisms</b> 2 modules 22.5 x 45 mm 2 way push button
5	5730 80	5731 80	1 way push button with bell symbol

## Arteor™ electronic switches

square version



5740 03

5740 01

5734 55



Support frames and plates selection charts **p. 134-137**  
Loads selection chart **p. 117**

Mechanisms supplied with white or magnesium square rocker plates  
To be equipped with support frames (p. 133) and plates (p. 134-147)

Pack	Cat. Nos.		Micropush switches - 100/240 V~
1	White 5740 04	Magnesium 5740 54	2 modules 22.5 x 45 mm <b>Without neutral</b> 2 way switch 400 W
1	White 5740 02	Black 5740 52	2 way switch 2 x 400 W with LED locator With magnesium push control Supplied with support frame
1	5740 03	5740 53	<b>With neutral</b> With magnesium push control 2 way switch 1 000 W with LED locator To be mounted on 2 module support frame
1	5740 00	5740 50	2 way switch 2 x 1 000 W with LED locator To be mounted on 2 module support frame
1	5740 01	5740 51	2 way switch 3 x 1 000 W with LED locator To be mounted on 2 module support frame

Pack	Cat. Nos.		Sensitive switches - 100/240 V~
1	White 5720 51	Magnesium 5734 55	For controlling light sources by simply passing the hand in front of the switch Up to 5 sensitive switches can be combined to control the same lighting circuit Supplied with LED indicator light 2 modules 22.5 x 45 mm

## Arteor™ electronic switches

round version



5743 00

5743 51

5736 55



Support frames and plates selection charts **p. 134-137**  
Loads selection chart **p. 117**

Mechanisms supplied with white or magnesium round rocker plates  
To be equipped with support frames (p. 133) and plates (p. 134-147)

Pack	Cat. Nos.		Micropush switches - 100/240 V~
1	White 5743 04	Magnesium 5743 54	2 modules 22.5 x 45 mm <b>Without neutral</b> 2 way switch 400 W
1	White 5743 02	Black 5743 52	2 way switch 2 x 400 W with LED locator With magnesium circular push control Supplied with support frame
1	5743 03	5743 53	<b>With neutral</b> With magnesium circular push control 2 way switch 1 000 W with LED locator To be mounted on 2 module support frame
1	5743 00	5743 50	2 way switch 2 x 1 000 W with LED locator To be mounted on 2 module support frame
1	5743 01	5743 51	2 way switch 3 x 1 000 W with LED locator To be mounted on 2 module support frame

Pack	Cat. Nos.		Sensitive switches - 100/240 V~
1	White 5725 51	Magnesium 5736 55	For controlling light sources by simply passing the hand in front of the switch Up to 5 sensitive switches can be combined to control the same lighting circuit Supplied with LED indicator light 2 modules 22.5 x 45 mm

## Arteor™ dimmers square version



5722 11

5740 08



Support frames and plates selection charts **p. 134-137**  
Loads selection chart **p. 117**

Mechanisms supplied with white or magnesium square cover plates  
To be equipped with support frames (p. 133) and plates (p. 134-147)

## Arteor™ dimmers round version



5743 55

5743 08

5743 59



Support frames and plates selection charts **p. 134-137**  
Loads selection chart **p. 117**

Mechanisms supplied with white or magnesium round rocker plates  
To be equipped with support frames (p. 133) and plates (p. 134-147)

Pack	Cat. Nos.		Dimmers 100/240 V~ - 50/60 Hz
1	White 5722 11 <sup>1</sup>	Magnesium 5727 11 <sup>1</sup>	<b>Resistive/inductive loads touch dimmers</b> Without neutral, 2 wire - 600 W Push button dimmer 2 modules 22.5 x 45 mm To be mounted on 3 module support frame
1	White 5740 07 <sup>1</sup>	Black 5740 57 <sup>1</sup>	<b>Leading/trailing edge dimmers</b> 2 x 400 W Push button dimmer With magnesium push control 2 modules 22.5 x 45 mm Supplied with support frame
1	White 5740 06 <sup>1</sup>	Magnesium 5740 56 <sup>1</sup>	600 W Push button dimmer 2 modules 22.5 x 45 mm To be mounted on 3 module support frame
1	White 5740 08	Black 5740 58	<b>Universal dimmers</b> With neutral, 3 wire - 300 W Can be used with compact fluorescent lamps Push button dimmer With magnesium push control 2 modules 22.5 x 45 mm To be mounted on 2 module support frame
1	5722 10 <sup>1</sup>	5727 10 <sup>1</sup>	<b>Dimmers 0-10 V</b> For ballasts 0-10 V Push button dimmer With magnesium push control 2 modules 22.5 x 45 mm To be mounted on 2 module support frame

Pack	Cat. Nos.		Dimmers 100/240 V~ - 50/60 Hz
1	White 5743 05 <sup>1</sup>	Magnesium 5743 55 <sup>1</sup>	<b>Resistive/inductive loads touch dimmers</b> Without neutral, 2 wire - 600 W Push button dimmer 2 modules 22.5 x 45 mm To be mounted on 3 module support frame
1	White 5743 07 <sup>1</sup>	Black 5743 57 <sup>1</sup>	<b>Leading/trailing edge dimmers</b> 2 x 400 W Push button dimmer With magnesium circular push control 2 modules 22.5 x 45 mm Supplied with support frame
1	White 5743 06 <sup>1</sup>	Magnesium 5743 56 <sup>1</sup>	600 W Push button dimmer 2 modules 22.5 x 45 mm To be mounted on 3 module support frame
1	White 5743 08	Black 5743 58	<b>Universal dimmers</b> With neutral, 3 wire - 300 W Can be used with compact fluorescent lamps Push button dimmer With magnesium circular push control 2 modules 22.5 x 45 mm To be mounted on 2 module support frame
1	5743 09 <sup>1</sup>	5743 59 <sup>1</sup>	<b>Dimmers 0-10 V</b> For ballasts 0-10 V Push button dimmer With magnesium circular push control 2 modules 22.5 x 45 mm To be mounted on 2 module support frame

1 : 2 way dimmer option available using additional push button (see p. 113)

1 : 2 way dimmer option available using additional push button (see p. 113)

**Arteor™ dimmers**  
lighting environment controller



5740 60

 Loads selection chart **p. 117**

Mechanism supplied complete with white or magnesium square cover plate, flush mounting box, support frame and plate

Pack	Cat. Nos.	Lighting environment controller				
1	<table border="1"> <tr> <td></td> <td></td> </tr> <tr> <td>White 5740 10<sup>1</sup></td> <td>Magnesium 5740 60<sup>2</sup></td> </tr> </table>			White 5740 10 <sup>1</sup>	Magnesium 5740 60 <sup>2</sup>	 <p>Main controller 3 x 1 000 W Particularly suitable for controlling lighting environments in conference rooms, meeting rooms, restaurants, showrooms, etc.</p> <p>Possible applications :</p> <ul style="list-style-type: none"> <li>- control of 3 lighting circuits in one room</li> <li>- control of lighting environments by dimming polychromatic lamps (red / green / blue or warm white / cold white)</li> </ul> <p>Sources supported per circuit :</p> <ul style="list-style-type: none"> <li>- 1 000 W for incandescent and halogen 230 V<math>\sim</math>,</li> <li>- 1 000 VA for fluorescent tubes with 0-10 V ballast,</li> <li>- 1 000 VA for ELV halogen lamps with ferromagnetic or electronic transformer</li> </ul> <p>The cumulative load of the 3 circuits must not exceed 2 200 W</p> <p>DALI input ballast and 0-10 V ballasts can be controlled</p> <p>Controls on front face :</p> <ul style="list-style-type: none"> <li>- 6 push buttons for on/off / dimming control of each of the 3 lighting circuits</li> <li>- 3 sets of 5 LEDs displaying the current level of each circuit</li> <li>- 4 push buttons for memorising and controlling lighting environments</li> </ul>
						
White 5740 10 <sup>1</sup>	Magnesium 5740 60 <sup>2</sup>					

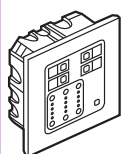

Main controller  
3 x 1 000 W  
Particularly suitable for controlling lighting environments in conference rooms, meeting rooms, restaurants, showrooms, etc.

Possible applications :

- control of 3 lighting circuits in one room
- control of lighting environments by dimming polychromatic lamps (red / green / blue or warm white / cold white)

Sources supported per circuit :

- 1 000 W for incandescent and halogen 230 V $\sim$ ,
- 1 000 VA for fluorescent tubes with 0-10 V ballast,
- 1 000 VA for ELV halogen lamps with ferromagnetic or electronic transformer

The cumulative load of the 3 circuits must not exceed 2 200 W

DALI input ballast and 0-10 V ballasts can be controlled

Controls on front face :

- 6 push buttons for on/off / dimming control of each of the 3 lighting circuits
- 3 sets of 5 LEDs displaying the current level of each circuit
- 4 push buttons for memorising and controlling lighting environments

1 : Supplied with white plate  
2 : Supplied with mirror black plate

**Arteor™ dimmers**  
lighting environment controller

■ Lighting environment controller

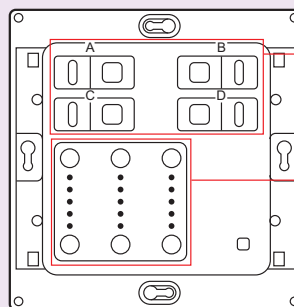

Choice of scenes :  
(factory configuration)  
A : 100 % C : OFF  
B : 66 % D : 33 %

Manual setting on each of 3 channels :  
light dimming / switching ON/OFF

**Wiring principle**

With 0-10 V ballasts

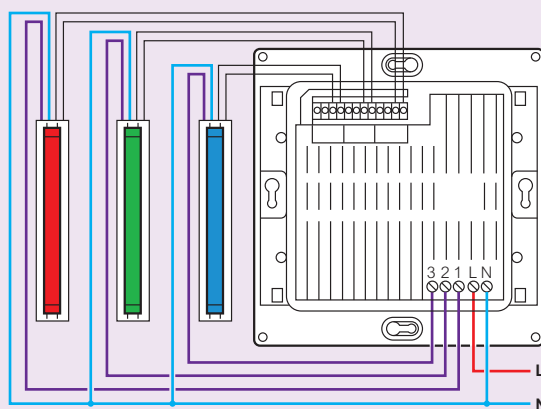

By controlling the RGB proportions, you can create scenes favouring warm or cold colours or scenes with dominant colours

The possibilities and results are identical using LED (lights) piloted by 0-10 V ballast

Possibility to mix channels with different types of lamps  
(example : 1 channel for 0-10 V ballast, 2 channels with incandescent lamp dimmer)

# Arteor™ loads selection chart

## ■ Electronic switches, dimmers, lighting environment controller max. loads

		Universal								
		Leading edge				Trailing edge				
Cat. Nos.										
		Incandescent lamp		Halogen lamp		ELV halogen with ferromagnetic transformer		ELV halogen with electronic transformer		
		110 V	230 V	110 V	230 V	110 V	230 V	110 V	230 V	
Micropush switches	5740 04/54 5743 04/54	200 W	400 W	200 W	400 W	200 VA	400 VA	200 VA	400 VA	
	5740 03/53 5743 03/53	500 W	1 000 W	500 W	1 000 W	250 VA	500 VA	250 VA	500 VA	
	5740 00/50 5743 00/50	2 x 500 W	2 x 1 000 W	2 x 500 W	2 x 1 000 W	2 x 250 VA	2 x 500 VA	2 x 250 VA	2 x 500 VA	
	5740 01/51 5743 01/51	3 x 500 W	3 x 1 000 W	3 x 500 W	3 x 1 000 W	3 x 250 VA	3 x 500 VA	3 x 250 VA	3 x 500 VA	
	5740 02/52 5743 02/52	2 x 200 W	2 x 400 W	2 x 200 W	2 x 400 W	2 x 200 VA	2 x 400 VA	2 x 200 VA	2 x 400 VA	
Sensitive switches	5720 51 5734 55 5725 51 5736 55	500 W	1 000 W	500 W	1 000 W	250 VA	500 VA	250 VA	500 VA	
	Dimmers	5740 06/56 5743 06/56	300 W	600 W	300 W	600 W	225 VA	450 VA	300 VA	600 VA
		5722 11 5727 11 5743 05/55	300 W	600 W	300 W	600 W	300 VA	600 VA	-	-
5740 08/58 5743 08/58		150 W	300 W	150 W	300 W	150 VA	300 VA	150 VA	300 VA	
5740 07/57 5743 07/57		2 x 200 W	2 x 400 W	2 x 200 W	2 x 400 W	2 x 200 VA	2 x 400 VA	2 x 200 VA	2 x 400 VA	
5740 10/60		1 100 W	2 200 W	1 100 W	2 200 W	1 100 VA	2 200 VA	1 100 VA	2 200 VA	

		Universal					
Cat. Nos.						LED	
		Fluorescent tube		Compact fluorescent lamp		LED	
		110 V	230 V	110 V	230 V	110 V	230 V
Micropush switches	5740 03/53 5743 03/53	250 VA	500 VA	250 VA	500 VA	250 VA	500 VA
	5740 00/50 5743 00/50	2 x 250 VA	2 x 500 VA	2 x 250 VA	2 x 500 VA	2 x 250 VA	2 x 500 VA
	5740 01/51 5743 01/51	3 x 250 VA	3 x 500 VA	3 x 250 VA	3 x 500 VA	3 x 250 VA	3 x 500 VA
Sensitive switches	5720 51 5734 55 5725 51 5736 55	250 VA	500 VA	250 VA	500 VA	250 VA	500 VA
Dimmers	5740 08/58 5743 08/58	-	-	80 VA	160 VA	80 VA	160 VA

Cat. Nos.							
		Ballasts 0-10 V		Ballasts DALI		Reducer motor for shutters	
		110 V	230 V	110 V	230 V	110 V	230 V
Micropush switches	5740 03/53 5743 03/53	-	-	-	-	50 VA	100 VA
	5740 00/50 5743 00/50	-	-	-	-	2 x 50 VA	2 x 100 VA
	5740 01/51 5743 01/51	-	-	-	-	3 x 50 VA	3 x 100 VA
Sensitive switches	5720 51 5734 55 5725 51 5736 55	-	-	-	-	50 VA	100 VA
Dimmers	5722 10 5727 10 5743 09/59	300 VA 40 mA	600 VA 40 mA	-	-	-	-
	5740 10/60	1 100 VA 50 mA	2 200 VA 50 mA	60 ballast	60 ballast	-	-

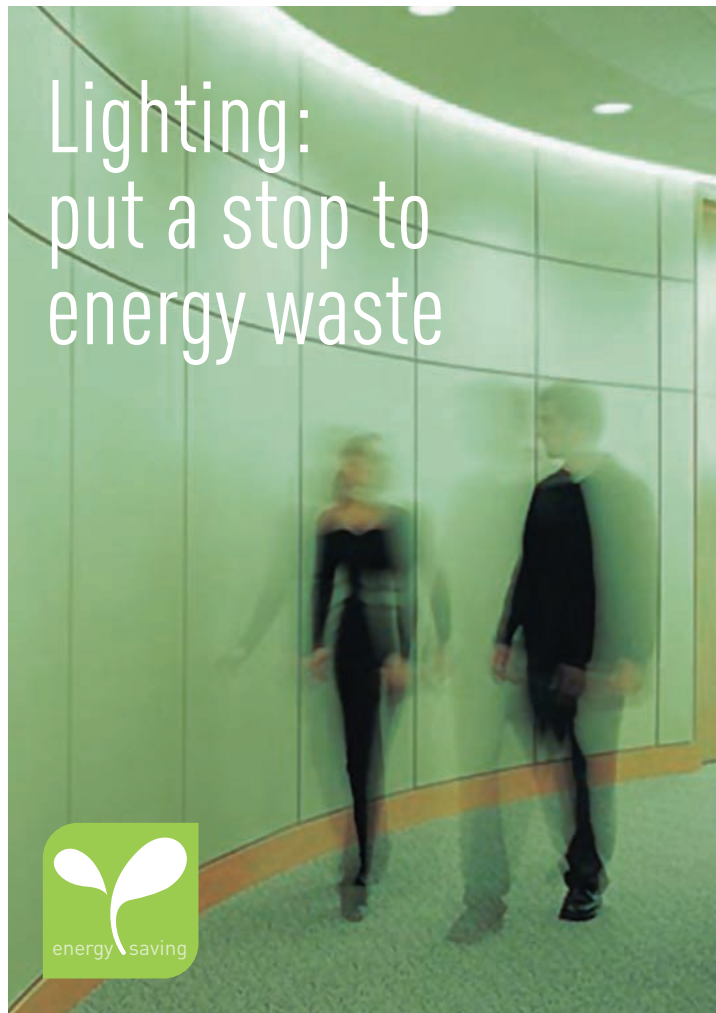

**Up to 20% of a building's electricity bill can be attributed to lighting. Legrand's occupancy sensors can help cut this cost.**

With a positive effect on the environment... and on the wallet... occupancy sensors automatically switch off lighting when it's not needed.

**PIR • ULTRASONIC • DUAL TECHNOLOGY**

Three different technologies are available, each offering simple installation and maintenance.



**Arteor™ automatic switches**



5720 53



5740 62



Lighting management p. 78-101



Support frames and plates selection charts p. 134-137

Mechanisms supplied with white or magnesium square cover plates  
To be equipped with support frames (p. 133) and plates (p. 134-147)

Pack	Cat. Nos.	Automatic switches - 100/240 V~
1	<div style="display: flex; justify-content: space-around;"> <div style="text-align: center;">                       White                      5720 53  </div> <div style="text-align: center;">                       Magnesium                      5740 61  </div> </div>	<p><b>With neutral, 3 wire - 1000 W</b></p> <p>Operates :                      - up to 1000 W incandescent and halogen lamps                      - up to 500 VA ELV halogen lamps with ferromagnetic or electronic transformer, fluorescent tubes and compact fluorescent lamps</p>
	<div style="display: flex; justify-content: space-around;"> <div style="text-align: center;">                       White                      5720 52  </div> <div style="text-align: center;">                       Magnesium                      5740 62  </div> </div>	<p><b>Without neutral, 2 wire - 400 W</b></p> <p>Operates :                      - up to 400 W incandescent and halogen lamps                      - up to 400 VA ELV halogen lamps with ferromagnetic or electronic transformer</p>



## Arteor™ lighting control



5720 55



Lighting management



p. 78-101



Support frames and plates selection charts p. 134-137

Mechanisms supplied with white or magnesium square cover plates  
To be equipped with support frames (p. 133) and plates (p. 134-147)

Pack	Cat. Nos.	Time delay switches				
1	<table border="1"> <tr> <td></td> <td></td> </tr> <tr> <td>White 5720 55</td> <td>Magnesium 5740 84</td> </tr> </table>			White 5720 55	Magnesium 5740 84	<p>Interference suppression conforming to standard EN 55022</p> <p>For timer control of a circuit with the following loads :</p> <ul style="list-style-type: none"> <li>- 1 000 W incandescent and halogen 230 V~</li> <li>- 2 300 W resistive (heating)</li> <li>- 400 VA fluorescent and ELV halogen</li> </ul> <p>Adjustable from 25 secs. to 15 mins.</p> <p>It is possible to install a number of timer switches in parallel on the same circuit</p> <p>2 wire installation in box min. depth 40 mm</p> <p>With integrated LED</p> <p>2 modules 22.5 x 45 mm</p>
White 5720 55	Magnesium 5740 84					
1	<table border="1"> <tr> <td></td> <td></td> </tr> <tr> <td>White 5722 27</td> <td>Magnesium 5727 27</td> </tr> </table>			White 5722 27	Magnesium 5727 27	<p><b>Single pole latching relays</b></p> <p>10 A - 250 V~ - 50/60 Hz</p> <p>With integrated push button</p> <p>Intensity 0.04 A</p> <p>2 modules 22.5 x 45 mm</p>
White 5722 27	Magnesium 5727 27					
10	<table border="1"> <tr> <td></td> <td></td> </tr> <tr> <td>White 5722 32</td> <td>Magnesium 5727 32</td> </tr> </table>			White 5722 32	Magnesium 5727 32	<p><b>Key switches</b></p> <p>Supplied with key</p> <p>1 module 22.5 x 45 mm</p> <p>2 way</p>
White 5722 32	Magnesium 5727 32					
10	<table border="1"> <tr> <td></td> <td></td> </tr> <tr> <td>White 5722 33</td> <td>Magnesium 5727 33</td> </tr> </table>			White 5722 33	Magnesium 5727 33	<p>Double pole</p>
White 5722 33	Magnesium 5727 33					

## Arteor™ visual indication



5727 26



5724 52



5724 23



Support frames and plates selection charts p. 134-137

Mechanisms supplied with white or magnesium square cover plates  
To be equipped with support frames (p. 133) and plates (p. 134-147)

Pack	Cat. Nos.	Miniature emergency lighting unit				
1	<table border="1"> <tr> <td></td> </tr> <tr> <td>White 5722 22</td> </tr> </table>		White 5722 22	<p>Illustrates automatically upon power failure</p> <p>Unclips from frame to become portable</p> <p>Can be permanently attached to frame</p> <p>LEDs indicating mains and charging status</p>		
White 5722 22						
1	<table border="1"> <tr> <td></td> <td></td> </tr> <tr> <td>White 5722 21</td> <td>Magnesium 5740 82</td> </tr> </table>			White 5722 21	Magnesium 5740 82	<p><b>Skirting lights</b></p> <p>2 modules 22.5 x 45 mm</p> <p>For installation close to obstacles</p> <p><b>Standard</b></p> <p>With LED 230 V - 0.2 or 1 W</p> <p>Square version</p> <p><b>With motion detector 100-240 V</b></p> <p>With IR detection cell and LED</p> <p>When a person passes, the mechanism detects the presence and lights the obstacle</p> <p>The function is equipped with an audible signal that can be disengaged</p> <p>Square version</p>
White 5722 21	Magnesium 5740 82					
10	<table border="1"> <tr> <td></td> </tr> <tr> <td>White 5724 52</td> </tr> </table>		White 5724 52	<p><b>Illuminated lighting unit</b></p> <p>230 V - 1 W</p> <p>Supplied with 4 coloured labels</p> <p>1 module 22.5 x 45 mm</p>		
White 5724 52						
10	<table border="1"> <tr> <td></td> </tr> <tr> <td>White 5724 53</td> </tr> </table>		White 5724 53	<p><b>Overdoor lighting units</b></p> <p>Supplied with diffusers and LED</p> <p>2 modules : 22.5 x 45 mm</p> <p>Red diffuser</p> <p>White diffuser</p>		
White 5724 53						
10	<table border="1"> <tr> <td></td> </tr> <tr> <td>White 5722 23</td> </tr> </table>		White 5722 23			
White 5722 23						
10	<table border="1"> <tr> <td></td> </tr> <tr> <td>White 5724 56</td> </tr> </table>		White 5724 56	<p><b>Lamps</b></p> <p>LED 230 V for locator switch - blue</p> <p>LED 230 V for indicator switch - red</p> <p>LED 12 V for indicator switch - red</p>		
White 5724 56						
10	<table border="1"> <tr> <td></td> </tr> <tr> <td>White 5724 55</td> </tr> </table>		White 5724 55			
White 5724 55						
10	<table border="1"> <tr> <td></td> </tr> <tr> <td>White 5724 54</td> </tr> </table>		White 5724 54			
White 5724 54						

## Arteor™ ventilation and heating control



5722 18



5722 03



Support frames and plates selection charts p. 134-137

Mechanisms supplied with white or magnesium square cover plates  
To be equipped with support frames (p. 133) and plates (p. 134-147)

Pack	Cat. Nos.		Fan controller
1	White 5722 18	Magnesium 5727 18	2 modules 22.5 x 45 mm Rotary speed controller for fan Operates 40 to 400 VA limit switch For progressive speed control of ceiling fan
1	White 5722 03	Magnesium 5727 03	<b>Thermostats</b> 2 modules 22.5 x 45 mm <b>Electronic room thermostat</b> Control dial with index and adjustable segments for min. and max. settings Adjustable range from 5 °C to 30 °C (+/- 0.5 °C) Power supply : 230 V~ - 50/60 Hz One potential free changeover contact output Suitable for controlling heated ceilings and underfloor heating - LV use breaking capacity : 8 A - 250 V~ - resistive inductive circuit 2 A - 250 V~ - inductive circuit - ELV use breaking capacity : 12 to 48 V~ - 12 to 24 V=, from 1 mA min. to 500 mA max.
1	White 5722 63	Magnesium 5727 63	<b>Thermostat for electric floor heating</b> With one potential free N/O contact and LED 16 A - 230 V~ Adjustable range from 10 °C to 60 °C With probe

## Arteor™ electric roller blind and curtain control



5722 19



5737 19



5727 20



5722 02



Support frames and plates selection charts p. 134-137

Mechanisms supplied with white or magnesium square rocker plates  
To be equipped with support frames (p. 133) and plates (p. 134-147)

Pack	Cat. Nos.		Electric roller blind control - 250 V~
10	White 5722 19	Magnesium 5727 19	<b>Push buttons</b> Double push button - 6 A For control via automatic box (N/O mechanism) 2 modules 22.5 x 45 mm Square version
10	White 5732 19	Magnesium 5737 19	Round version
10	White 5722 20	Magnesium 5727 20	<b>Switches</b> Double switch - 10 A For direct control of a motor (mechanism with fixed positions) 2 modules 22.5 x 45 mm Square version
10	White 5732 20	Magnesium 5737 20	Round version
5	White 5722 02	Magnesium 5727 02	<b>Curtain control</b> 1 module 22.5 x 45 mm Curtain switch centre off
5	White 5722 01	Magnesium 5727 01	Curtain switch centre retract

## Arteor™ hotel equipment

square version – lighting, electric roller blind and curtain control



## Arteor™ hotel equipment

round version – lighting, electric roller blind and curtain control



Support frames and plates selection charts p. 134-137

Mechanisms supplied with white or magnesium square rocker plates  
To be equipped with support frames (p. 133) and plates (p. 134-147)



Support frames and plates selection charts p. 134-137

Mechanisms supplied with white or magnesium round rocker plates  
To be equipped with support frames (p. 133) and plates (p. 134-147)

Pack	Cat. Nos.		Lighting control with specific marking
	White	Magnesium	
10	5732 84	5737 84	<b>Master controls</b> Master switch 2 way double pole 20 AX - 250 V~ for general control : all ON / all OFF 2 modules 22.5 x 45 mm
10	5732 86	5737 86	Master push button 2 way - 6 A - 250 V~ for general control : all ON / all OFF 2 modules 22.5 x 45 mm
10	5732 94	5737 94	<b>Controls for bed lights</b> 2 x 2 way switch 10 AX - 250 V~ 2 x 1 module 22.5 x 45 mm
10	5732 96	5737 96	2 x 2 way push button 6 A - 250 V~ 2 x 1 module 22.5 x 45 mm
10	5733 82	5738 82	<b>Controls for desk and entrance lights</b> 2 x 2 way switch 10 AX - 250 V~ 2 x 1 module 22.5 x 45 mm
10	5733 84	5738 84	2 x 2 way push button 6 A - 250 V~ 2 x 1 module 22.5 x 45 mm

Pack	Cat. Nos.		Lighting control with specific marking
	White	Magnesium	
10	5732 85	5737 85	<b>Master controls</b> Master switch 2 way double pole 20 AX - 250 V~ for general control : all ON / all OFF 2 modules 22.5 x 45 mm
10	5732 87	5737 87	Master push button 2 way - 6 A - 250 V~ for general control : all ON / all OFF 2 modules 22.5 x 45 mm
10	5732 95	5737 95	<b>Controls for bed lights</b> 2 x 2 way switch 10 AX - 250 V~ 2 x 1 module 22.5 x 45 mm
10	5732 97	5737 97	2 x 2 way push button 6 A - 250 V~ 2 x 1 module 22.5 x 45 mm
10	5733 83	5738 83	<b>Controls for desk and entrance lights</b> 2 x 2 way switch 10 AX - 250 V~ 2 x 1 module 22.5 x 45 mm
10	5733 85	5738 85	2 x 2 way push button 6 A - 250 V~ 2 x 1 module 22.5 x 45 mm

Pack	Cat. Nos.		Electric roller blind control with specific marking - 250 V~
	White	Magnesium	
10	5732 22	5737 22	Double switch - 10 A For direct control of a motor (mechanism with fixed positions) Roller blinds marking 2 modules 22.5 x 45 mm
10	5732 24	5737 24	Double push button - 6 A For control via automatic box (N/O mechanism) Roller blinds marking 2 modules 22.5 x 45 mm

Pack	Cat. Nos.		Electric roller blind control with specific marking - 250 V~
	White	Magnesium	
10	5732 23	5737 23	Double switch - 10 A For direct control of a motor (mechanism with fixed positions) Roller blinds marking 2 modules 22.5 x 45 mm
10	5732 25	5737 25	Double push button - 6 A For control via automatic box (N/O mechanism) Roller blinds marking 2 modules 22.5 x 45 mm

Pack	Cat. Nos.		Curtain control with specific marking - 250 V~
	White	Magnesium	
10	5732 34	5737 34	Double switch - 10 A For direct control of a motor (mechanism with fixed positions) Curtain marking 2 modules 22.5 x 45 mm
10	5732 36	5737 36	Double push button - 6 A For control via automatic box (N/O mechanism) Curtain marking 2 modules 22.5 x 45mm

Pack	Cat. Nos.		Curtain control with specific marking - 250 V~
	White	Magnesium	
10	5732 35	5737 35	Double switch - 10 A For direct control of a motor (mechanism with fixed positions) Curtain marking 2 modules 22.5 x 45 mm
10	5732 37	5737 37	Double push button - 6 A For control via automatic box (N/O mechanism) Curtain marking 2 modules 22.5 x 45mm

**Arteor™ hotel equipment**  
BUS and Radio scenario controllers



5745 87



5745 91

**Arteor™ hotel equipment**  
key fob switches, shaver sockets



5727 30



5721 53

Plates selection charts p. 134-137

Support frames and plates selection charts p. 134-137

Mechanisms supplied with white or magnesium square cover plates  
To be equipped with support frames (p. 133) and plates (p. 134-147)

Pack	Cat. Nos.	Scenario controllers with specific marking
		<p><b>Radio controls</b> 4-scenes micropush control Surface mounting, no wiring needed For BUS or radio installations Mechanisms equipped with white or black round cover plate and magnesium circular push control for 4 scenarios Supplied with support frames and batteries To be equipped with plates (p. 134-147) 2 modules 22.5 x 45 mm</p>
1	5740 87   5745 87	<p>White   Black "wake up / sleep / TV / relax" marking</p>
1	5740 88   5745 88	<p>"wake up / sleep / open curtains / close curtains" marking</p>
		<p><b>Touch plates for radio controls</b> 4-scenes touch plate British Standard fixing centres</p>
1	5740 90   5745 90	<p>"wake up / sleep / TV / relax" marking Can replace standard rocker plates and plates on 4-scenes radio controllers Cat. Nos. 5740 87, 5745 87</p>
1	5740 93   5745 93	<p>"wake up / sleep / open curtains / close curtains" marking Can replace standard rocker plate and plates on 4-scenes radio controllers Cat. Nos. 5740 88, 5745 88</p>
		<p><b>BUS controls</b> 4-scenes touch control for the activation of 4 scenarios : "wake up / sleep / TV / relax" 2 module mechanisms For British Standard flush mounting boxes</p>
1	5740 89   5745 89	
1	5740 91   5745 91	<p>6-scenes touch control for the activation of 6 scenarios : "wake up / sleep / TV / relax / open curtains / close curtains" 3 module mechanisms For British, Italian and American Standard flush mounting boxes</p>

Pack	Cat. Nos.	Accessories
10	5740 92	Sheet of stickers with symbols for different scenarios for hotel rooms
10	5745 92	Dark colour White colour

**Complete home automation solutions** (see p. 44-73)

Pack	Cat. Nos.	Key card switches
1	5722 30   5727 30	<p>Energise a circuit by inserting a key card or fob (e.g. hotel room, meeting room) Time-delay of approx. 30 secs. after card removal 2 modules 22.5 x 45 mm</p>
1	5722 31   5734 93	<p><b>Mechanical key card switches</b> Key fob switches 230 V Use with key fob Cat. Nos. 5722 59 and 5727 59 or a smart card (access card for a hotel room) Key card switches 12-24 V To be equipped with single pole latching relay Cat. Nos. 5722 27 and 5727 27 (p. 119)</p>
1	5722 53   5727 53	<p><b>Key card switches RFID</b> Works only with ISO type contactless key card Cat. Nos. 0767 11 or other ISO type 13.56 MHz key card Key card switches RFID Low capacity contact 230 V - 30 VA Lighting of the slot by LED</p>
		<p><b>Key fobs and key card</b> <b>For mechanical key card switches</b> Key fob Enables use of key fob switches in hotels with key locks Supplied complete with a label holder for individual hotel identification</p>
10	5722 59   5727 59	
10	0767 11	<p><b>For RFID key card switches</b> MIFARE contactless badge card ISO format (50 x 80 mm) Chip: 13.56 MHz Standard 1 KB memory</p>
		<p><b>Shaver sockets</b> Conform to BS EN 61558-2-5. IP 24 For use with European, British, American, Australian 2-pin plugs Screwless live and neutral terminals Double wound isolating transformer Automatic self-resetting overload feature Plug insertion operates micro-switch which energises transformer To be equipped with BS 2 gang - 3 module plates (p. 134-147) For flush mounting boxes, use BS 2 gang box depth 48 mm, US type, Italian type boxes depth 48 mm Power supply : 230 V - 50/60 Hz 3 modules 22.5 x 45 mm 230 V / 120-230 V With earth connector</p>
1	5721 53   5726 53	

## Arteor™ hotel equipment

square version – call indicators, illuminated signs, buzzers



5720 57

5725 54

5722 24



Support frames and plates selection charts p. 134-137

Mechanisms supplied with white or magnesium square rocker plates  
To be equipped with support frames (p. 133) and plates (p. 134-147)

Pack	Cat. Nos.	Hotel bedroom call indicators				
5	<table border="1"> <tr> <td>White</td> <td>Magnesium</td> </tr> <tr> <td>5720 57</td> <td>5725 57</td> </tr> </table>	White	Magnesium	5720 57	5725 57	<p>Enables the resident to inform hotel staff of the room status Two settings are possible :</p> <ul style="list-style-type: none"> <li>- Do not disturb</li> <li>- Please clean the room</li> </ul> <p>1 + 1 modules 22.5 x 45 mm</p> <p><b>Indicator</b> Indicator lamp and bell push Installed in the corridor, display calls Supplied with LEDs</p>
White	Magnesium					
5720 57	5725 57					
5	5720 54   5725 54	<p><b>Internal control unit</b> Allows the user to select the desired setting Supplied with LEDs</p>				

Pack	Cat. Nos.	Illuminated signs				
5	<table border="1"> <tr> <td>White</td> <td>Magnesium</td> </tr> <tr> <td>5722 24</td> <td>5727 24</td> </tr> </table>	White	Magnesium	5722 24	5727 24	<p>Mechanisms integrating LEDs and a pivoting window that can take customised labels (printed using a simple text editor on transparent printing paper) 2 modules 22.5 x 45 mm</p> <p><b>Green or Red</b> Sign with 2-state LEDs with choice of green or red configurable on the mechanism 1 W</p>
White	Magnesium					
5722 24	5727 24					
5	5722 25   5727 22	<p><b>Blue</b> Sign with blue LED A choice of 2 power levels : 0.2 or 1 W</p>				

Pack	Cat. Nos.	Buzzers				
10	<table border="1"> <tr> <td>White</td> <td>Magnesium</td> </tr> <tr> <td>5722 07</td> <td>5722 47</td> </tr> </table>	White	Magnesium	5722 07	5722 47	<p>230 V 2 modules 22.5 x 45 mm</p>
White	Magnesium					
5722 07	5722 47					

## Arteor™ hotel equipment

round version – call indicators, illuminated signs, buzzers



5725 67

5725 74



Support frames and plates selection charts p. 134-137

Mechanisms supplied with white or magnesium round rocker plates  
To be equipped with support frames (p. 133) and plates (p. 134-147)

Pack	Cat. Nos.	Hotel bedroom call indicators				
5	<table border="1"> <tr> <td>White</td> <td>Magnesium</td> </tr> <tr> <td>5720 67</td> <td>5725 67</td> </tr> </table>	White	Magnesium	5720 67	5725 67	<p>Enables the resident to inform hotel staff of the room status Two settings are possible :</p> <ul style="list-style-type: none"> <li>- Do not disturb</li> <li>- Please clean the room</li> </ul> <p>1 + 1 modules 22.5 x 45 mm</p> <p><b>Indicator</b> Indicator lamp and bell push Installed in the corridor, display calls Supplied with LEDs</p>
White	Magnesium					
5720 67	5725 67					
5	5720 74   5725 74	<p><b>Internal control unit</b> Allows the user to select the desired setting Supplied with LEDs</p>				

Pack	Cat. Nos.	Illuminated signs		
5	<table border="1"> <tr> <td>Magnesium</td> </tr> <tr> <td>5727 25</td> </tr> </table>	Magnesium	5727 25	<p>Mechanisms integrating LEDs and a pivoting window that can take customised labels (printed using a simple text editor on transparent printing paper) 2 modules 22.5 x 45 mm</p> <p><b>Green or Red</b> Sign with 2-state LEDs with choice of green or red configurable on the mechanism 1 W</p>
Magnesium				
5727 25				
5	5727 23	<p><b>Blue</b> Sign with blue LED A choice of 2 power levels : 0.2 or 1 W</p>		

Pack	Cat. Nos.	Buzzers				
10	<table border="1"> <tr> <td>White</td> <td>Magnesium</td> </tr> <tr> <td>5722 08</td> <td>5722 48</td> </tr> </table>	White	Magnesium	5722 08	5722 48	<p>230 V 2 modules 22.5 x 45 mm</p>
White	Magnesium					
5722 08	5722 48					

**NEW**

## Arteor™ USB chargers square version



5720 78



5720 71





Technical information **p. 125**  
Support frames and plates selection charts **p. 134-137**

Mechanisms supplied with rocker plates, to be equipped with support frames (p. 133) and plates (p. 134-147)

Average charging time for devices equipped with lithium-ion polymer batteries :

- 80 % charged < 2 h
- 100 % charged < 4 h

No specific constraint : no need to wait for the battery to be flat before charging, or to have it fully charged before use

Pack	Cat. Nos.	USB power supplies		
5/1	<table border="1"> <tr> <td>White 5720 78</td> <td>Magnesium 5725 78</td> </tr> </table>	White 5720 78	Magnesium 5725 78	<p>For recharging portable devices Conform to IEC 62684-2011-01 Consumption in passive mode &lt; 0.3 W 2P + E tap-off connection via 2.5 mm<sup>2</sup> screw terminals Supplied cordless</p> <p><b>Double USB sockets - 5 V - 1500 mA</b> For fast-charging telephones, smartphones, MP3/MP4 players and tablet PC</p>  2 modules
White 5720 78	Magnesium 5725 78			
10	5720 71   5725 71	<p><b>Single USB sockets - 5 V - 750 mA</b> For Smartphone</p>  1 module		

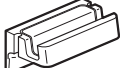
1	0803 99	<p><b>Support for portable device on charge</b></p> <p>Prevents device from any fall risk and allows secure use of device while charging Wall mounting Fixing tools supplied</p>  For 1 portable device
---	---------	----------------------------------------------------------------------------------------------------------------------------------------------------------------------------------------------------------------------------------------------------------------------------------------------------

**NEW**

## Arteor™ USB chargers round version



5724 88





Technical information **p. 125**  
Support frames and plates selection charts **p. 134-137**

Mechanisms supplied with rocker plates, to be equipped with support frames (p. 133) and plates (p. 134-147)

Average charging time for devices equipped with lithium-ion polymer batteries :

- 80 % charged < 2 h
- 100 % charged < 4 h

No specific constraint : no need to wait for the battery to be flat before charging, or to have it fully charged before use

Pack	Cat. Nos.	USB power supplies		
1	<table border="1"> <tr> <td>White 5724 88</td> <td>Magnesium 5733 98</td> </tr> </table>	White 5724 88	Magnesium 5733 98	<p>For recharging portable devices Conform to IEC 62684-2011-01 Consumption in passive mode &lt; 0.3 W 2P + E tap-off connection via 2.5 mm<sup>2</sup> screw terminals Supplied cordless</p> <p><b>Double USB sockets - 5 V - 1500 mA</b> For fast-charging telephones, smartphones, MP3/MP4 players and tablet PC</p>  2 modules
White 5724 88	Magnesium 5733 98			
1	0803 99	<p><b>Support for portable device on charge</b></p> <p>Prevents device from any fall risk and allows secure use of device while charging Wall mounting Fixing tools supplied</p>  For 1 portable device		

# Arteor™ USB chargers

## ■ Installation

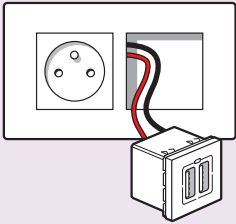

By simple tap-off on 2P + E socket  
 Wiring 1.5 or 2.5 mm<sup>2</sup>  
 Class II product which does not require earthing  
 Releases a 2P + E socket recess

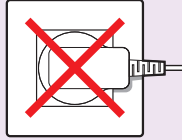

**Environment :**  
 Helps to reduce waste associated with the discarding of mobile chargers that have become unusable (50 000 tonnes/year) and thus the associated greenhouse gas emissions (13.5 million tonnes equivalent)  
 Reduces standby consumption by more than 50% in comparison with a mobile charger  
 Performance required by standard EN 62684 : 0.5 W  
 Legrand performance : < 0.3 W

## ■ Universal power supplies

The flush mounting charger is always available for use, providing freedom from the restrictions of a mobile charger and extending battery life for users on the move

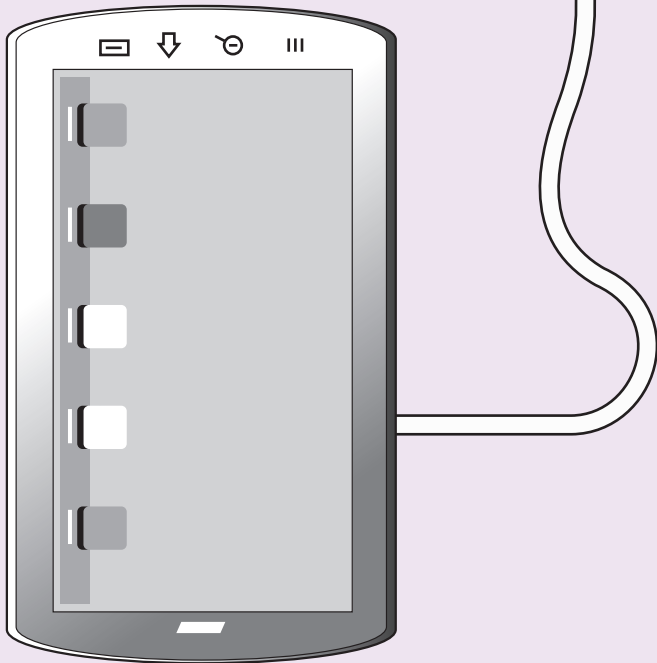
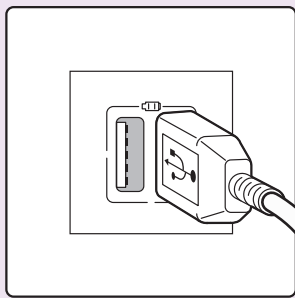

1500 mA version : can simultaneously charge two mobile terminals conforming to EN 62684 or PC tablet (fast charging)

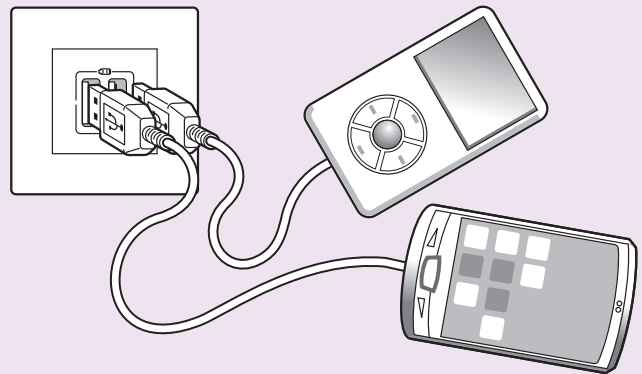

750/1500 mA version : ideal for everyday needs

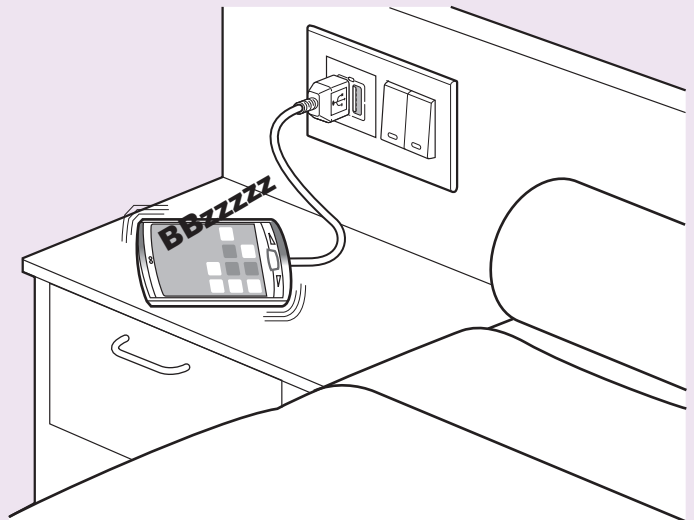

# Arteor™ data, audio and video sockets

square version



Support frames and plates selection charts **p. 134-137**

Mechanisms supplied with white or magnesium square cover plates  
To be equipped with support frames (p. 133) and plates (p. 134-147)

Pack	Cat. Nos.		Data sockets
10			<b>RJ 45 tool-less system - CAT 6</b> Rapid connection socket. No tool required UTP - 8 contacts 2 modules 22.5 x 45 mm  <b>USB female data sockets</b> Used to bring connections closer to the user For connecting USB devices (scanner-printer, external hard disk) Recommended cable : USB A max. cable length 5 m Cross-section 1 mm <sup>2</sup> Connection via screw terminals 1 module 22.5 x 45 mm  Preconnected Equipped with a 15 cm cord 1 module 22.5 x 45 mm
	White 5723 14	Magnesium 5728 14	
1	5722 75	5727 75	<b>NEW</b>
1	5720 94	5727 94	

Pack	Cat. Nos.		Audio and video sockets
1			<b>2 x female RCA</b> For the stereo audio connection of any DVD drive, camera, video recorder, etc. type peripheral Recommended cable : 1 shielded audio pair 1 module 22.5 x 45 mm  <b>3 x female RCA</b> For the composite video and stereo audio connection of a DVD drive, camera, video recorder, video conference equipment etc. Recommended cable : 1 shielded audio pair + 1 x 3 mm mini-coaxial 1 module 22.5 x 45 mm  <b>YUV</b> For analogue high definition connection of a DVD, PC monitor, plasma screen, video projector, graphic paintbox, etc. Recommended cable : 3 x 3 mm mini-coaxial (max. cable length 25 m) or 3 x RG59 coaxial (max. cable length 50 m) 1 module 22.5 x 45 mm  <b>Female 3.5 mm jack</b> For stereo audio connection from a portable source Recommended cable : 1 x 0.22 mm <sup>2</sup> shielded audio pair Connection on screw terminals 1 module 22.5 x 45 mm
	White 5722 72	Magnesium 5727 72	
1	5722 73	5727 73	
1	5722 71	5727 71	

Pack	Cat. Nos.		Audio and video sockets (continued)
1			<b>Female HD 15</b> For VGA, XGA or VESA connection of a PC monitor, plasma screen, video projector, graphic paintbox, etc. Recommended cable Cat. No. 0327 81 Max. cable length 25 m (beyond this a VGA amplifier is recommended) Connection on screw terminals 2 modules 22.5 x 45 mm  Solder connection 1 module 22.5 x 45 mm  <b>HDMI</b> For digital high definition audio and video connection of a PC monitor, plasma screen, video projector, graphic paintbox, etc. Recommended cable Cat. No. 0327 80 2 modules 22.5 x 45 mm  <b>NEW</b>
	White 5722 82	Magnesium 5727 82	
1	5722 79	5727 79	
1	5722 81	5727 81	
1	5720 96	5725 96	Preconnected Equipped with a 15 cm cord 1 module 22.5 x 45 mm
1	5744 01	5744 51	<b>S-Video socket (4-pin mini-DIN)</b> 1 gang Provides the YC video link for any peripheral device such as a DVD drive, camera, video recorder, videoconferencing, etc 1 module 22.5 x 45 mm
1	5722 76	5727 76	<b>Female BNC 75</b> For the composite video connection of any DVD drive, camera, video recorder, etc. Recommended cable : RG59 coaxial Max. cable length : 10 m 1 module 22.5 x 45 mm
1	0327 80		<b>Cables for connecting 2 sockets</b>  <b>HDMI cable</b> Length 20 m For connecting HDMI sockets at a distance of up to 10 m  <b>VGA cable</b> Length 20 m For connecting full pin HD 15 sockets at a distance of up to 20 m
1	0327 81		



# Arteor™ data, audio and video sockets

## round version



5728 24



5732 74



5737 73



5727 85



5745 01



More television, telephone, data, audio and video sockets  
p. 128



Support frames and plates selection charts p. 134-137

Mechanisms supplied with white or magnesium round cover plates  
To be equipped with support frames (p. 133) and plates (p. 134-147)

Pack	Cat. Nos.		Data sockets
10	White	Magnesium	<b>RJ 45 tool-less system - CAT 6</b> Rapid connection socket. No tool required UTP - 8 contacts 2 modules 22.5 x 45 mm
	5723 24	5728 24	
1	White	Magnesium	<b>USB sockets</b> Used to bring connections closer to the user For connecting USB devices (scanner-printer, external hard disk) Recommended cable : USB A max. cable length 5 m
	5732 74	5737 74	
1	White	Magnesium	Connection via screw terminals Cross-section 1 mm <sup>2</sup> 2 modules 22.5 x 45 mm
1	White	Magnesium	Preconnected Equipped with a 15 cm cord 2 modules 22.5 x 45 mm

Pack	Cat. Nos.		Audio and video sockets (continued)
1	White	Magnesium	<b>HDMI</b> For digital high definition audio and video connection of a PC monitor, plasma screen, video projector, graphic paintbox, etc. Recommended cable Cat. No. 0327 80 2 modules 22.5 x 45 mm
	5722 85	5727 85	
1	White	Magnesium	Preconnected Equipped with a 15 cm cord 1 module 22.5 x 45 mm
1	White	Magnesium	<b>S-Video socket (4-pin mini-DIN)</b> 1 gang Provides the YC video link for any peripheral device such as a DVD drive, camera, video recorder, videoconferencing, etc. 2 modules 22.5 x 45 mm

Pack	Cat. Nos.		Audio and video sockets
1	White	Magnesium	<b>2 x female RCA</b> For the stereo audio connection of any DVD drive, camera, video recorder, etc. type peripheral Recommended cable : 1 shielded audio pair 2 modules 22.5 x 45 mm
	5732 72	5737 72	
1	White	Magnesium	<b>3 x female RCA</b> For the composite video and stereo audio connection of a DVD drive, camera, video recorder, video conference equipment etc. Recommended cable : 1 shielded audio pair + 1 x 3 mm mini-coaxial 2 modules 22.5 x 45 mm
1	White	Magnesium	5732 73   5737 73

Pack	Cat. Nos.	Cable for connecting 2 sockets
1	0327 80	<b>HDMI cable</b> Length 20 m For connecting HDMI sockets at a distance of up to 10 m

## Arteor™ television and telephone sockets



5721 72



5726 72



5723 00



Support frames and plates selection charts p. 134-137

Mechanisms supplied with white or magnesium square cover plates  
To be equipped with support frames (p. 133) and plates (p. 134-147)

Pack	Cat. Nos.		Television sockets
			For aerial and satellite installation (with individual demodulator) DTT and HDTV compatible TV : male connector (Ø9.5 mm) attenuation ≤ 1.5 db R : female connector (Ø9.5 mm) attenuation ≤ 1.5 db SAT : "F" type connector attenuation ≤ 2 db Recommended coaxial cable : 17/19 VATC
10	5721 63	5726 63	<b>TV sockets</b> TV single shielded "F" type with screws 0-2400 MHz 1 module 22.5 x 45 mm
10	5721 71	5726 71	TV single shielded male Ø9.5 mm 0-2400 MHz 1 module 22.5 x 45 mm
10	5721 70	5726 70	<b>TV-R socket</b> TV-R shielded socket female-male Ø9.5 mm 2 modules 22.5 x 45 mm
10	5721 72	5726 72	<b>TV-R-SAT socket</b> TV-R-SAT shielded socket 0-2400 MHz 2 modules 22.5 x 45 mm

Pack	Cat. Nos.		Television socket (Ø 9/9.5 female)
			TV 0-860 MHz
20	5721 73	5726 73	TV single Non-isolated

Pack	Cat. Nos.		Telephone sockets
			With IDC connection
10	5723 10 <sup>1</sup>	5728 10 <sup>1</sup>	Single master 2 modules 22.5 x 45 mm
5	5723 01 <sup>1</sup>	5728 01 <sup>1</sup>	Single secondary 1 module 22.5 x 45 mm

Pack	Cat. Nos.		RJ 11 sockets
			Equipped with modular jack connector with 1/4 turn terminal for fast connection (possible looping)
10	5723 00	5728 00	4 contacts 1 module 22.5 x 45 mm

## Arteor™ data sockets and wiring splitter



5723 06



5728 02



5723 31



5728 35



Support frames and plates selection charts p. 134-137

Mechanisms supplied with white or magnesium square cover plates  
To be equipped with support frames (p. 133) and plates (p. 134-147)  
Certified as conforming to standards ISO 11801 ed. 2.0, EN 50173-1 and EIA/TIA 568  
Contacts marked with 568 A and B dual colour code and numbers  
Connectors with self-stripping terminals  
Possibility of re-wiring in the event of error  
Multidirectional cable entry

Pack	Cat. Nos.		RJ 45 - tool-less system
			Rapid connection sockets. No tool required
			<b>10 Giga</b> Supports 10 G base-T applications up to 100 m in a channel conforming to ISO/IEC TIA TSB 155 and IEEE 802.3an
10	5723 06	5728 06	STP/FTP - 9 contacts, shielded folded metal 1 module 22.5 x 45 mm
			<b>CAT 6</b>
10	5723 23	5728 23	STP - 9 contacts, shielded folded metal 1 module 22.5 x 45 mm
10	5723 22	5728 22	FTP - 9 contacts 1 module 22.5 x 45 mm
10	5723 02	5728 02	UTP - 8 contacts 1 module 22.5 x 45 mm
10	5723 24	5728 24	UTP - 8 contacts 2 modules 22.5 x 45 mm Round version
			<b>CAT 5e</b>
10	5723 04	5728 04	FTP - 9 contacts 1 module 22.5 x 45 mm
10	5723 03	5728 03	UTP - 8 contacts 1 module 22.5 x 45 mm

Pack	Cat. Nos.		Rear pluggable RJ 45 sockets
			Connection to boxes via RJ 45-RJ 45 dedicated cords Used to create CAT 6 and CAT 5e links in accordance with standards 2 modules 22.5 x 45 mm
			<b>CAT 6</b>
10	5723 31	5728 31	UTP
10	5723 33	5728 33	FTP

Pack	Cat. Nos.		Telephone/Ethernet wiring splitters
			Provide increased security against theft and damage to double connectors Provide a rate of 10/100 Mbps Multidirectional cable entry Can be installed in all supports min. depth 35 mm Telephone and Ethernet applications marked on the protective cap
10	5723 35	5728 35	1 module 22.5 x 45 mm UTP double connector 8 contacts

1 : Not suitable for use in the ROI

## Arteor™ adaptors for data sockets and USB sockets



Support frames and plates selection charts p. 134-137

Adaptors and mechanisms supplied with white or magnesium cover plate  
To be equipped with support frames (p. 133) and plates (p. 134-147) and connector (for adaptors)

Pack	Cat. Nos.		Adaptors for data sockets
			Equipped with transparent label holder
10	White 5723 05	Magnesium 5728 05	<b>Ortronics</b> Adaptor for single Clarity TRACKJACK connector Straight plug 1 module 22.5 x 45 mm
10	5723 34	5728 34	Adaptor for single Clarity TRACKJACK connector Inclined plug 2 modules 22.5 x 45 mm
10	5723 18	5728 18	Adaptor for single Clarity Rear load connector Straight plug 1 module 22.5 x 45 mm
10	5723 37	5728 37	<b>Keystone</b> Adaptor for single connector 2 modules 22.5 x 45 mm
10	5723 38	5728 38	<b>Systemax</b> Adaptor for single connector 2 modules 22.5 x 45 mm

Pack	Cat. Nos.		USB female sockets
			Used to bring connections closer to the user For connecting USB devices (scanner-printer, external hard disk) Connection via screw terminals cross-section 1 mm <sup>2</sup> Recommended cable : USB A
1	White 5722 75	Magnesium 5727 75	Square version 1 module 22.5 x 45 mm
1	5732 74	5737 74	Round version 2 modules 22.5 x 45 mm

## Arteor™ attenuator and loudspeaker sockets



Support frames and plates selection charts p. 134-137

Mechanisms supplied with white or magnesium square cover plate  
To be equipped with support frames (p. 133) and plates (p. 134-147)

Pack	Cat. Nos.		Attenuator
1	White 5722 84	Magnesium 5727 84	100 V - 25 W Allow to adjust power to 25 W from a balanced 100 V loudspeaker line 2 modules 22.5 x 45 mm
			<b>3-pole XLR sockets</b> For the stereo connection of any peripheral, microphone, mixing console Recommended microphone cable : 1 x 0.22 mm <sup>2</sup> shielded audio pair Recommended speaker cable : 1 x 1.5 mm <sup>2</sup> audio pair (will take 2.5 mm <sup>2</sup> ) Max. cable length : 50 m (beyond this an audio amplifier is recommended) 2 modules 22.5 x 45 mm
1	White 5722 83	Magnesium 5727 83	Neutrik female
1	5722 77	5727 77	Neutrik male
			<b>Loudspeaker sockets</b>
10	White 5722 70	Magnesium 5727 70	4 mm <sup>2</sup> terminals 1 module 22.5 x 45 mm
10	5722 80	5727 80	4 mm <sup>2</sup> terminals 2 modules 22.5 x 45 mm
			<b>Home cinema loudspeaker sockets</b>
10	White 5722 90	Magnesium 5727 90	2 connectors 2 modules 22.5 x 45 mm
5	5722 91	5727 91	4 connectors 3 modules 22.5 x 45 mm

## Arteor™ detectors



Support frames and plates selection charts **p. 134-137**

Mechanisms supplied with white or magnesium square cover plates  
To be equipped with support frames (p. 133) and plates (p. 134-147)

Pack	Cat. Nos.		<b>Water leak detectors</b>
1	White 5740 15	Magnesium 5740 65	Indicates with a LED the presence of a conducting liquid. The point at which flooding is alerted is determined by the installation height of the sensor. Consumption : - 0.1 mA in stand-by mode - 25 mA in alarm mode 2 modules 22.5 x 45 mm

Pack	Cat. Nos.		<b>Gas detectors</b>
1	White 5740 14	Magnesium 5740 64	Indicates the presence of gas via a LED and audible alarm signal 85 dB at 1 m. 2 modules 22.5 x 45 mm <b>LPG/Propane/Butane gas detectors</b> Consumption max. 2 W in alarm mode
1	5740 13	5740 63	<b>Methane gas detectors</b> Consumption max. 2 W in alarm mode

Pack	Cat. Nos.		<b>Accessories</b>
1	White 5740 35	Magnesium 5740 85	To be used with detectors 2 wire connection 2 modules 22.5 x 45 mm <b>Transformers</b> 230 V - 12 V
1	5740 36	5740 86	<b>Actuators</b> For technical alarms

## Arteor™ RCBO and fuse carrier units



Support frames and plates selection charts **p. 134-137**

Mechanisms supplied with square cover plates  
To be equipped with support frames (p. 133) and plates (p. 134-147)

Pack	Cat. Nos.	<b>RCBO</b>
1	White 5723 60	Single pole + neutral - 30 mA 16 A - 230 V~ The RCBO is used to protect people (premises with a conductive floor, presence of water, etc...) against direct contact with live parts or leakages to earth. With test button 2 modules 22.5 x 45 mm

Pack	Cat. Nos.		<b>Fuse carrier units</b>
10	White 5721 58	Magnesium 5726 58	For 13 A fuses

# Arteor™ British and International standard socket outlets



Support frames and plates selection charts **p. 134-137**

Mechanisms supplied with white, magnesium or red square cover plates  
To be equipped with support frames (p. 133) and plates (p. 134-147)

Pack	Cat. Nos.		British standard socket outlets
10	White 5721 10	Magnesium 5726 10	Shuttered for child safety Use 2 or 3 module plates and support frames (p. 133-147) <b>5 A</b> Conform to BS 546 2P + E 2 modules 22.5 x 45 mm 
	5721 11 <sup>1</sup>	5726 11 <sup>1</sup>	<b>13 A</b> Conform to BS 1363 : Part 2 2P + E ASTA licence 2 modules 22.5 x 45 mm 
5	5721 30	5726 30	2P + E switched ASTA licence 3 modules 22.5 x 45 mm 
5	Red 5724 67		2P + E switched - dedicated non-standard pin 3 modules 22.5 x 45 mm 
5	White 5721 32	Magnesium 5726 32	<b>15 A</b> Conform to BS 546 2P + E switched 3 modules 22.5 x 45 mm 

Pack	Cat. Nos.		International standards socket outlets
10	White 5721 18	Magnesium 5726 18	Not suitable for domestic installations in the UK and Ireland <b>German</b> 16 A 2P + E Shuttered for child safety 2 modules 22.5 x 45 mm 
	5721 19	5726 19	2P + E with cover 2 modules 22.5 x 45 mm 
10	5720 21	5725 21	<b>French</b> 10/16 A 2P + E shuttered for child safety 2 modules 22.5 x 45 mm 

Pack	Cat. Nos.		International standards socket outlets (continued)
Not suitable for domestic installations in the UK and Ireland			
<b>Euro-US type socket outlets</b> 15 A-127 V / 10 A-250 V With shutters Special care should be taken when specifying and installing these sockets			
10	White 5721 04	Magnesium 5726 04	2P 1 module 22.5 x 45 mm 
	5721 16	5726 16	2P + E 2 modules 22.5 x 45 mm 
5	5721 33	5726 33	2 x 2P + E 3 modules 22.5 x 45 mm 
<b>American</b> 15 A - 127 V			
10	5721 17	5726 17	2P + E 2 modules 22.5 x 45 mm 
<b>South African</b> 16 A Conform to SANS 164 Shuttered for child safety			
5	5721 32	5726 32	2P + E switched 3 modules 22.5 x 45 mm 
<b>ELV socket outlets</b> 10/16 A			
10	5721 03	5726 03	2P + E shuttered for child safety 
<b>Switzerland</b> 10 A Shuttered for child safety			
10	White 5721 15		2P + E Type 13 - 2 modules 22.5 x 45 mm 
<b>China</b> 10 A Shuttered for child safety			
10	White 5721 13	Magnesium 5726 13	2P + E 2 modules 22.5 x 45 mm 

<sup>1</sup> : when using two or more Arteor unswitched 13 A sockets (5721 11/5726 11) next to each other, it is necessary to separate the sockets with a 1 module spacer (572341/572841). (p. 132)

## Arteor™ ancillary mechanisms

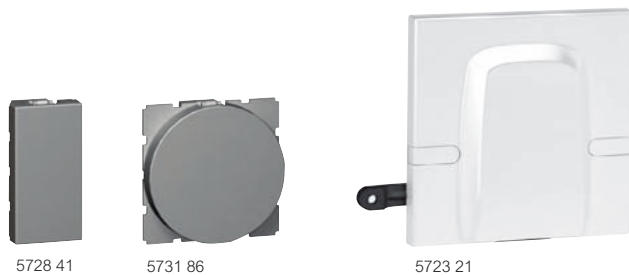

5728 41      5731 86      5723 21

Support frames and plates selection charts **p. 134-137**

Mechanisms supplied with white or magnesium cover plates  
To be equipped with support frames (p. 133) and plates (p. 134-147)

Pack	Cat. Nos.	Blank modules
10	White 5723 41	<b>Square version</b> 1 module 22.5 x 45 mm
	Magnesium 5728 41	
10	5723 42    5728 42	2 modules 22.5 x 45 mm
10	5730 86    5731 86	<b>Round version</b> 2 modules 22.5 x 45 mm

Pack	Cat. Nos.	Cable outlets
10	White 5723 20	Square version mechanisms 20 A cable outlet for junction 2 modules 22.5 x 45 mm
5	5723 21	45 A cable outlet - BS 1 gang Supplied with white cover plate For flush mounting back box min. depth 45 mm

Pack	Cat. Nos.	Cord outlets
10	White 5723 07	Square version mechanisms Cord outlet with Ø8 mm entry 1 module 22.5 x 45 mm
10	5723 19	Cord outlet 2 modules 22.5 x 45 mm

## Arteor™ blanking cover plates



5751 31

Support frames and plates selection charts **p. 134-137**

Square version plates  
3 finishes : White, Pearl Alu and Graphite

Pack	Cat. Nos.	Blanking cover plates
<b>For 1 gang box</b>		
5	5751 30	<ul style="list-style-type: none"> <li>○ White</li> <li>● Pearl Alu</li> <li>● Graphite</li> </ul>
5	5751 31	
5	5751 32	
<b>For 2 gang box</b>		
5	5751 40	<ul style="list-style-type: none"> <li>○ White</li> <li>● Pearl Alu</li> <li>● Graphite</li> </ul>
5	5751 41	
5	5751 42	

## Arteor™ support frames

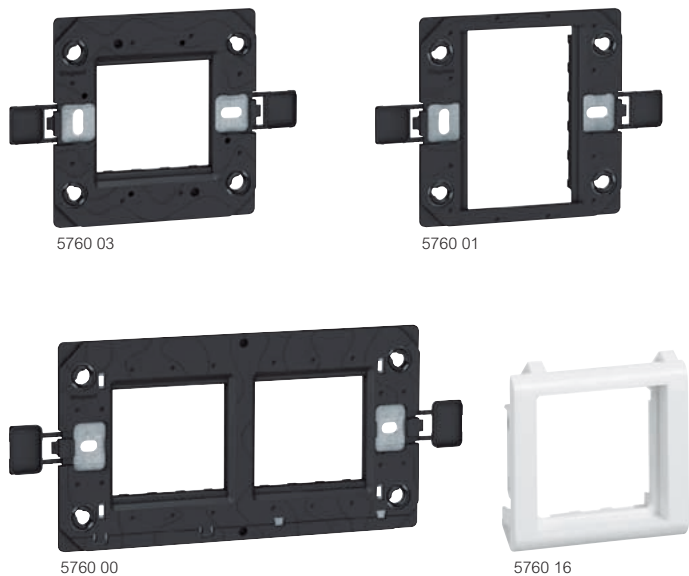

Support frames and plates selection charts p. 134-137

Pack	Cat. Nos.	Support frames for BS type boxes 60-3 mm fixing centres
10	5760 03	Screw mounting (screws supplied) Accept mechanisms horizontally or vertically <b>For 1 gang box</b> Square - for 1 or 2 modules
5	5760 01	Square - for 3 modules
10	5760 02	<b>For 2 gang box</b> Rectangular - for 3 modules
10	5760 00	Rectangular - for 2 x 2 modules

Pack	Cat. Nos.	Panel mounting supports
10	5760 15	For 1 to 3 mm thick panels For 1 module 22.5 x 45 mm Clips into a 28 x 53.5 mm aperture
10	5760 16	For 2 modules 22.5 x 45 mm Clips into a 58 x 53.5 mm aperture

Pack	Cat. Nos.	Modular support
10	5760 13	For mounting 2 module mechanisms on symmetrical rail

## Arteor™ back boxes and IP 44 plate



Support frames and plates selection charts p. 134-137

Pack	Cat. Nos.	Surface mounting boxes
10	5723 90	<b>For British, German and French standards</b> For 2 modules - 1 gang 38 mm depth
5	5723 92	For 4 horizontal modules 2 x 2 modules - 2 gang 48 mm depth (suitable for shaver socket)
1	5723 96	For 2 x 6 modules 38 mm depth

Pack	Cat. Nos.	Flush mounting galvanised steel back boxes
1	6890 27	<b>Depth 42 mm</b> For 6 module plate assemblies Dimensions : 72 x 212 mm
1	6890 28	For 12 module plate assemblies Dimensions : 143 x 212 mm
1	0818 56	For 18 module plate assemblies (fitted with voltage separation barrier) Dimensions : 212 x 212 mm
1	6890 38	For 8 module plate assemblies Dimensions : 72 x 227 mm

Pack	Cat. Nos.	IP 44 plate
5	5751 90	<b>For British and German standards</b> For mounting in 1 gang box Support frame supplied 96 x 94 mm

# Arteor™ back boxes, support frames and plates

square version

Number of modules per mechanism	Back boxes	Support frames	Plates	PLATES						
				Neutral			Tattoo	Graphic		
				White	Pearl Alu	Graphite	Edition 1	Casual	Formal	
<b>SQUARE VERSION</b>										
1 module	1 gang <sup>1</sup>	5760 03		5752 00	5752 01	5752 02	5761 08	5761 01	5761 02	
2 modules and 1-2" touch screen	1 gang <sup>1</sup>	5760 03 5760 01 <sup>3</sup>		5752 10	5752 11	5752 12	5761 28	5761 21	5761 22	
3 modules - 1 gang	1 gang <sup>1</sup>	5760 01		5751 60	5751 61	5751 62	5761 88	5761 81	5761 82	
3 modules and shaver sockets	2 gang <sup>2</sup>	5760 02		5750 70	5750 71	5750 72	5761 68	5761 61	5761 62	
4 modules	2 gang <sup>2</sup>	5760 00		5750 80	5750 81	5750 82	5761 48	5761 41	5761 42	
6 modules	5723 93 (surface mounting) 6890 27 (flush mounting)	Supplied with plate		5753 70	5753 71	5753 72	5763 78	5763 71	5763 72	
2 x 6 modules	5723 96 (surface mounting) 6890 28 (flush mounting)	Supplied with plate		5753 90	5753 91	5753 92	-	-	-	
3 x 6 modules	0818 56 (flush mounting)	Supplied with plate		5754 00	5754 01	5754 02	-	-	-	
8 modules	8218 59 (flush mounting)	Supplied with plate		5767 00	5767 01	5767 02	5767 18	5767 11	5767 12	
For 5 A/13 A switched socket outlet - 1 gang	1 gang <sup>1</sup>	Not required		5750 90	5750 91	5750 92	5762 18	5762 11	5762 12	
For 13 A twin switched socket outlet - 2 gang	2 gang <sup>2</sup>	Not required		5751 00	5751 01	5751 02	5762 08	5762 01	5762 02	
For 13 A fused connection unit - switched	1 gang <sup>1</sup>	Not required		5751 20	5751 21	5751 22	5761 98	5761 91	5761 92	
For cooker unit Cat. No. 5720 88	2 gang <sup>2</sup>	Not required		5751 50	-	-	-	-	-	
Blanking cover plate British standard	1 gang <sup>1</sup>	5760 03 or 5760 01		5751 30	5751 31	5751 32	-	-	-	
Blanking cover plate British standard	2 gang <sup>2</sup>	5760 02		5751 40	5751 41	5751 42	-	-	-	

**British standard 60-3 mm fixing centres**

- 1 : Suitable for use with 1 gang back boxes. For Legrand options, see p. 133
- 2 : Suitable for use with 2 gang back boxes. For Legrand options, see p. 133
- 3 : Use 5760 01 support frame for 2 module mechanisms to be mounted on 3 module support frame, see p. 133



PLATES

PLATES											
	Mirror				Brushed metal		Wood		Leather		Signature
	Mirror white	Mirror black	Mirror red	Mirror taupe	Stainless steel	Gold brass	Wenge style	Light oak	Club	Galuchat	Woven metal
5752 04	5752 03	5761 06	5761 05	5752 06	5761 00	5752 05	5761 09	5761 03	5761 04	5761 07	
5752 14	5752 13	5761 26	5761 25	5752 16	5761 20	5752 15	5761 29	5761 23	5761 24	5761 27	
5751 64	5751 63	5761 86	5761 85	5751 66	5761 80	5751 65	5761 89	5761 83	5761 84	5761 87	
5750 74	5750 73	5761 66	5761 65	5750 76	5761 60	5750 75	5761 69	5761 63	5761 64	5761 67	
5750 84	5750 83	5761 46	5761 45	5750 86	5761 40	5750 85	5761 49	5761 43	5761 44	5761 47	
5753 74	5753 73	5763 76	5763 75	5753 76	5763 70	5753 75	5763 79	5763 73	5763 74	5763 77	
-	-	-	-	-	-	-	-	-	-	-	
-	-	-	-	-	-	-	-	-	-	-	
5767 04	5767 03	5767 16	5767 15	5767 06	5767 10	5767 05	5767 19	5767 13	5767 14	5767 17	
5750 94	5750 93	5762 16	5762 15	5750 96	5762 10	5750 95	5762 19	5762 13	5762 14	5762 17	
5751 04	5751 03	5762 06	5762 05	5751 06	5762 00	5751 05	5762 09	5762 03	5762 04	5762 07	
5751 24	5751 23	5761 96	5761 95	5751 26	5761 90	5751 25	5761 99	5761 93	5761 94	5761 97	
-	-	-	-	-	-	-	-	-	-	-	
-	-	-	-	-	-	-	-	-	-	-	
-	-	-	-	-	-	-	-	-	-	-	

## Arteor™ back boxes, support frames and plates

round version

Number of modules per mechanism	Back boxes	Support frames	Plates	PLATES					
				Neutral			Tattoo	Graphic	
				White	Pearl Alu	Graphite	Edition 1	Casual	Formal
ROUND VERSION									
2 modules	1 gang <sup>1</sup>	5760 03		5756 10	5756 11	5756 12	5761 18	5761 11	5761 12
3 modules	2 gang <sup>2</sup>	5760 02		5755 40	5755 41	5755 42	5761 58	5761 51	5761 52
3 modules - 1 gang	1 gang <sup>1</sup>	5760 01		5755 60	5755 61	5755 62	5761 78	5761 71	5761 72
4 modules	2 gang <sup>2</sup>	5760 00		5755 50	5755 51	5755 52	5761 38	5761 31	5761 32
6 modules	6890 27 (flush mounting)	Supplied with plate		5767 40	5767 41	5767 42	5767 58	5767 51	5767 52
2 x 6 modules	6890 28 (flush mounting)	Supplied with plate		5756 90	5756 91	5756 92	-	-	-
8 modules	8218 59 (flush mounting)	Supplied with plate		5766 80	5766 81	5766 82	5766 98	5766 91	5766 92

### British standard 60·3 mm fixing centres

1 : Suitable for use with 1 gang back boxes. For Legrand options, see p. 133  
 2 : Suitable for use with 2 gang back boxes. For Legrand options, see p. 133

## Arteor™ back boxes and plates

special items

Mechanisms	Flush mounting boxes for dry partitions	Plates	PLATES						
			Neutral			Tattoo	Graphic		
			White	Pearl Alu	Graphite	Edition 1	Casual	Formal	
Video internal display unit 2·5" BUS alarm module 3·5" touch screen	0893 79 (concrete walls) 0892 79 (dry partition walls)		-	-	-	-	-	-	-
10" multimedia touch screen	Not required		-	-	-	-	-	-	-
Central unit for temperature control	Supplied with box		-	-	-	-	-	-	-

PLATES

	Mirror				Brushed metal		Wood		Leather		Signature
	Mirror white	Mirror black	Mirror red	Mirror taupe	Stainless steel	Gold brass	Wenge style	Light oak	Club	Galuchat	Woven metal
5756 14	5756 13	5761 16	5761 15	5756 16	5761 10	5756 15	5761 19	5761 13	5761 14	5761 17	
5755 44	5755 43	5761 56	5761 55	5755 46	5761 50	5755 45	5761 59	5761 53	5761 54	5761 57	
5755 64	5755 63	5761 76	5761 75	5755 66	5761 70	5755 65	5761 79	5761 73	5761 74	5761 77	
5755 54	5755 53	5761 36	5761 35	5755 56	5761 30	5755 55	5761 39	5761 33	5761 34	5761 37	
5767 44	5767 43	5767 56	5767 55	5767 46	5767 50	5767 45	5767 59	5767 53	5767 54	5767 57	
-	-	-	-	-	-	-	-	-	-	-	
5766 84	5766 83	5766 96	5766 95	5766 86	5766 90	5766 85	5766 99	5766 93	5766 94	5766 97	

PLATES

	Mirror				Brushed metal		Wood		Leather		Signature
	Mirror white	Mirror black	Mirror red	Mirror taupe	Stainless steel	Gold brass	Wenge style	Light oak	Club	Galuchat	Woven metal
5764 84	5764 83	-	-	5764 86	5764 80	-	-	-	-	5764 87	
5765 14	5765 13	-	-	5765 16	5765 10	-	-	-	-	5765 17	
5765 24	5765 23	-	-	5765 26	5765 20	-	-	-	-	5765 37	

## Arteor™ plates square version

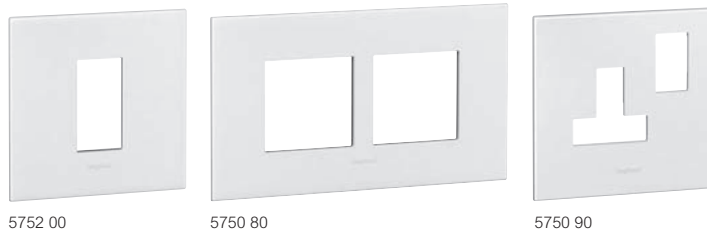

Support frames and plates selection charts p. 134-137

## Arteor™ plates round version



Support frames and plates selection charts p. 134-137

Pack	Cat. Nos.	Neutral	Dimensions in mm
10	White 5752 00	<b>British standard</b> 1 module	92 x 92
10	5752 10	2 modules	92 x 92
5	5750 70	3 modules	157 x 92
5	5751 60	3 modules 1 gang horizontal and vertical mounting	92 x 92
5	5750 80	4 modules	157 x 92
5	5753 70	6 modules Supplied with support frame	237.5 x 92
2	5753 90	2 x 6 modules Supplied with support frame	237.5 x 178
2	5754 00	3 x 6 modules Supplied with support frame	237.5 x 246
2	5767 00	8 modules Supplied with support frame	252.5 x 92
10	5750 90	For 5 A/13 A switched socket outlet - 1 gang	92 x 92
10	5751 00	For 13 A twin switched socket outlet - 2 gang	157 x 92
5	5751 20	For 13 A fused connection unit switched	92 x 92
5	5751 50	Plate for cooker unit Cat. No. 5720 88 (p. 109)	157 x 92

**For blanking plates** (see p. 132)

Pack	Cat. Nos.	Neutral	Dimensions in mm
10	White 5756 10	<b>British standard</b> 2 modules	92 x 92
5	5755 40	3 modules	157 x 92
5	5755 60	3 modules 1 gang horizontal and vertical mounting	92 x 92
5	5755 50	4 modules	157 x 92
2	5767 40	6 modules Supplied with support frame	237.5 x 92
2	5756 90	2 x 6 modules Supplied with support frame	237.5 x 178
2	5766 80	8 modules Supplied with support frame	252.5 x 92

**For blanking plates** (see p. 132)

## Arteor™ plates square version



5752 11

5752 12

5751 62

Support frames and plates selection charts p. 134-137

## Arteor™ plates round version



5756 11

5755 61

5755 62

Support frames and plates selection charts p. 134-137

Pack	Cat. Nos.		Neutral	Dimensions in mm
10	Pearl Alu 5752 01	Graphite 5752 02	<b>British standard</b> 1 module	92 x 92
10	5752 11	5752 12	2 modules	92 x 92
5	5750 71	5750 72	3 modules	157 x 92
5	5751 61	5751 62	3 modules 1 gang horizontal and vertical mounting	92 x 92
5	5750 81	5750 82	4 modules	157 x 92
5	5753 71	5753 72	6 modules Supplied with support frame	237.5 x 92
2	5753 91	5753 92	2 x 6 modules Supplied with support frame	237.5 x 178
2	5754 01	5754 02	3 x 6 modules Supplied with support frame	237.5 x 246
2	5767 01	5767 02	8 modules Supplied with support frame	252.5 x 92
10	5750 91	5750 92	For 5 A/13 A switched socket outlet 1 gang	92 x 92
10	5751 01	5751 02	For 13 A twin switched socket outlet 2 gang	157 x 92
5	5751 21	5751 22	For 13 A fused connection unit switched	92 x 92

**For blanking plates** (see p. 132)

Pack	Cat. Nos.		Neutral	Dimensions in mm
10	Pearl Alu 5756 11	Graphite 5756 12	<b>British standard</b> 2 modules	92 x 92
5	5755 41	5755 42	3 modules	157 x 92
5	5755 61	5755 62	3 modules 1 gang horizontal and vertical mounting	92 x 92
5	5755 51	5755 52	4 modules	157 x 92
2	5767 41	5767 42	6 modules Supplied with support frame	237.5 x 92
2	5756 91	5756 92	2 x 6 modules Supplied with support frame	237.5 x 178
2	5766 81	5766 82	8 modules Supplied with support frame	252.5 x 92

**For blanking plates** (see p. 132)

## Arteor™ plates square version



5761 28

5761 48

5762 18

## Arteor™ plates round version



5761 18

5761 58



Support frames and plates selection charts p. 134-137



Support frames and plates selection charts p. 134-137

Pack	Cat. Nos.	Tattoo	Dimensions in mm
5	Edition 1 5761 08	<b>British standard</b> 1 module	92 x 92
5	5761 28	2 modules	92 x 92
5	5761 68	3 modules	157 x 92
5	5761 88	3 modules 1 gang horizontal and vertical mounting	92 x 92
5	5761 48	4 modules	157 x 92
5	5763 78	6 modules Supplied with support frame	237.5 x 92
2	5767 18	8 modules Supplied with support frame	252.5 x 92
1	5762 18	For 5 A/13 A switched socket outlet - 1 gang	92 x 92
1	5762 08	For 13 A twin switched socket outlet - 2 gang	157 x 92
1	5761 98	For 13 A fused connection unit switched	92 x 92

Pack	Cat. Nos.	Tattoo	Dimensions in mm
5	Edition 1 5761 18	<b>British standard</b> 2 modules	92 x 92
5	5761 58	3 modules	157 x 92
5	5761 78	3 modules 1 gang horizontal and vertical mounting	92 x 92
5	5761 38	4 modules	157 x 92
2	5767 58	6 modules Supplied with support frame	237.5 x 92
2	5766 98	8 modules Supplied with support frame	252.5 x 92

## Arteor™ plates square version



5761 21

5761 22

5761 81

Support frames and plates selection charts p. 134-137

## Arteor™ plates round version

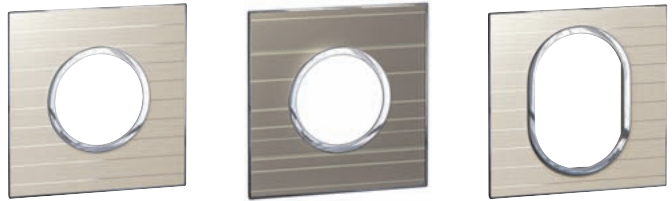

5761 11

5761 12

5761 71

Support frames and plates selection charts p. 134-137

Pack	Cat. Nos.		Graphic	Dimensions in mm
1	Casual 5761 01	Formal 5761 02	<b>British standard</b> 1 module 	92 x 92
1	5761 21	5761 22	2 modules 	92 x 92
1	5761 61	5761 62	3 modules 	157 x 92
1	5761 81	5761 82	3 modules 1 gang horizontal and vertical mounting 	92 x 92
1	5761 41	5761 42	4 modules 	157 x 92
1	5763 71	5763 72	6 modules Supplied with support frame 	237.5 x 92
1	5767 11	5767 12	8 modules Supplied with support frame 	252.5 x 92
1	5762 11	5762 12	For 5 A/13 A switched socket outlet 1 gang 	92 x 92
1	5762 01	5762 02	For 13 A twin switched socket outlet - 2 gang 	157 x 92
1	5761 91	5761 92	For 13 A fused connection unit switched 	92 x 92

Pack	Cat. Nos.		Graphic	Dimensions in mm
1	Casual 5761 11	Formal 5761 12	<b>British standard</b> 2 modules 	92 x 92
1	5761 51	5761 52	3 modules 	157 x 92
1	5761 71	5761 72	3 modules 1 gang horizontal and vertical mounting 	92 x 92
1	5761 31	5761 32	4 modules 	157 x 92
1	5767 51	5767 52	6 modules Supplied with support frame 	237.5 x 92
1	5766 91	5766 92	8 modules Supplied with support frame 	252.5 x 92

## Arteor™ plates square version



5752 03

5752 14

5750 93

Support frames and plates selection charts p. 134-137

## Arteor™ plates round version



5756 14

5755 43

5755 63

Support frames and plates selection charts p. 134-137

Pack	Cat. Nos.		Mirror		Dimensions in mm
1	5752 04	5752 03	<b>British standard</b>	1 module	92 x 92
1	5752 14	5752 13		2 modules	92 x 92
1	5750 74	5750 73		3 modules	157 x 92
1	5751 64	5751 63		3 modules 1 gang horizontal and vertical mounting	92 x 92
1	5750 84	5750 83		4 modules	157 x 92
1	5753 74	5753 73		6 modules Supplied with support frame	237.5 x 92
1	5767 04	5767 03		8 modules Supplied with support frame	252.5 x 92
1	5750 94	5750 93		For 5 A/13 A switched socket outlet 1 gang	92 x 92
1	5751 04	5751 03		For 13 A twin switched socket outlet 2 gang	157 x 92
1	5751 24	5751 23		For 13 A fused connection unit switched	92 x 92
1	5764 84	5764 83	<b>Special plates</b>	For video internal display unit 2.5", BUS alarm module and 3.5" touch screen	127 x 127
1	5765 14	5765 13		For 10" multimedia touch screen	309 x 233
1	5765 24	5765 23		For central unit for temperature control	165 x 176

Pack	Cat. Nos.		Mirror		Dimensions in mm
1	5756 14	5756 13	<b>British standard</b>	2 modules	92 x 92
1	5755 44	5755 43		3 modules	157 x 92
1	5755 64	5755 63		3 modules 1 gang horizontal and vertical mounting	92 x 92
1	5755 54	5755 53		4 modules	157 x 92
1	5767 44	5767 43		6 modules Supplied with support frame	237.5 x 92
1	5766 84	5766 83		8 modules Supplied with support frame	252.5 x 92



## Arteor™ plates square version



5761 26



5761 25

Support frames and plates selection charts p. 134-137

## Arteor™ plates round version



5761 16



5761 15



5761 75

Support frames and plates selection charts p. 134-137

Pack	Cat. Nos.		Mirror	British standard	Dimensions in mm
1	5761 06	5761 05	Mirror red / Mirror taupe	1 module	92 x 92
1	5761 26	5761 25		2 modules	92 x 92
1	5761 66	5761 65		3 modules	157 x 92
1	5761 86	5761 85		3 modules 1 gang horizontal and vertical mounting	92 x 92
1	5761 46	5761 45		4 modules	157 x 92
1	5763 76	5763 75		6 modules Supplied with support frame	237.5 x 92
1	5767 16	5767 15		8 modules Supplied with support frame	252.5 x 92
1	5762 16	5762 15		For 5 A/13 A switched socket outlet 1 gang	92 x 92
1	5762 06	5762 05		For 13 A twin switched socket outlet 2 gang	157 x 92
1	5761 96	5761 95		For 13 A fused connection unit switched	92 x 92

Pack	Cat. Nos.		Mirror	British standard	Dimensions in mm
1	5761 16	5761 15	Mirror red / Mirror taupe	2 modules	92 x 92
1	5761 56	5761 55		3 modules	157 x 92
1	5761 76	5761 75		3 modules 1 gang horizontal and vertical mounting	92 x 92
1	5761 36	5761 35		4 modules	157 x 92
1	5767 56	5767 55		6 modules Supplied with support frame	237.5 x 92
1	5766 96	5766 95		8 modules Supplied with support frame	252.5 x 92

## Arteor™ plates square version

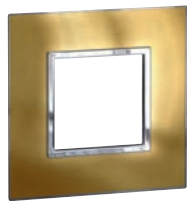

5761 20



5752 16

Support frames and plates selection charts **p. 134-137**

## Arteor™ plates round version



5761 10



5761 70



5755 46

Support frames and plates selection charts **p. 134-137**

Pack	Cat. Nos.		Brushed metal	Dimensions in mm
	Gold brass	Stainless steel		
1	5761 00	5752 06	<b>British standard</b> 1 module	92 x 92
1	5761 20	5752 16	2 modules	92 x 92
1	5761 60	5750 76	3 modules	157 x 92
1	5761 80	5751 66	3 modules 1 gang horizontal and vertical mounting	92 x 92
1	5761 40	5750 86	4 modules	157 x 92
1	5763 70	5753 76	6 modules Supplied with support frame	237.5 x 92
1	5767 10	5767 06	8 modules Supplied with support frame	252.5 x 92
1	5762 10	5750 96	For 5 A and 13 A switched socket outlet 1 gang	92 x 92
1	5762 00	5751 06	For 13 A twin switched socket outlet 2 gang	157 x 92
1	5761 90	5751 26	For 13 A fused connection unit 1 gang	92 x 92
1	5764 80	5764 86	<b>Special plates</b> For video internal display unit 2.5", BUS alarm module and 3.5" touch screen	127 x 127
1	5765 10	5765 16	For 10" multimedia touch screen	309 x 233
1	5765 20	5765 26	For central unit for temperature control	165 x 176

Pack	Cat. Nos.		Brushed metal	Dimensions in mm
	Gold brass	Stainless steel		
1	5761 10	5756 16	<b>British standard</b> 2 modules	92 x 92
1	5761 50	5755 46	3 modules	157 x 92
1	5761 70	5755 66	3 modules 1 gang horizontal and vertical mounting	92 x 92
1	5761 30	5755 56	4 modules	157 x 92
1	5767 50	5767 46	6 modules Supplied with support frame	237.5 x 92
1	5766 90	5766 86	8 modules Supplied with support frame	252.5 x 92

## Arteor™ plates square version



5752 15



5761 29

Support frames and plates selection charts p. 134-137

## Arteor™ plates round version



5756 15



5761 19

Support frames and plates selection charts p. 134-137

Pack	Cat. Nos.		Wood	British standard	Dimensions in mm
1	5752 05	5761 09	Wenge style Light oak	1 module	92 x 92
1	5752 15	5761 29		2 modules	92 x 92
1	5750 75	5761 69		3 modules	157 x 92
1	5751 65	5761 89		3 modules 1 gang horizontal and vertical mounting	92 x 92
1	5750 85	5761 49		4 modules	157 x 92
1	5753 75	5763 79		6 modules Supplied with support frame	237.5 x 92
1	5767 05	5767 19		8 modules Supplied with support frame	252.5 x 92
1	5750 95	5762 19		For 5 A/13 A switched socket outlet 1 gang	92 x 92
1	5751 05	5762 09		For 13 A twin switched socket outlet 2 gang	157 x 92
1	5751 25	5761 99		For 13 A fused connection unit switched	92 x 92

Pack	Cat. Nos.		Wood	British standard	Dimensions in mm
1	5756 15	5761 19	Wenge style Light oak	2 modules	92 x 92
1	5755 45	5761 59		3 modules	157 x 92
1	5755 65	5761 79		3 modules 1 gang horizontal and vertical mounting	92 x 92
1	5755 55	5761 39		4 modules	157 x 92
1	5767 45	5767 59		6 modules Supplied with support frame	237.5 x 92
1	5766 85	5766 99		8 modules Supplied with support frame	252.5 x 92

**Arteor™ plates**  
square version



5761 23

5761 24

5761 84

 Support frames and plates selection charts **p. 134-137**

**Arteor™ plates**  
round version

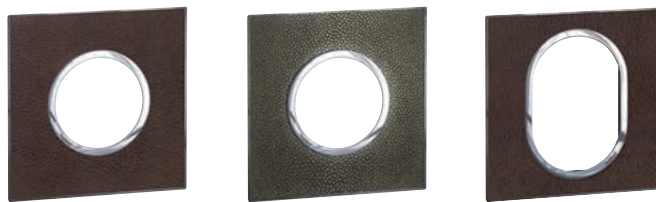

5761 13

5761 14

5761 73

 Support frames and plates selection charts **p. 134-137**

Pack	Cat. Nos.		Leather		Dimensions in mm
1	Club 5761 03	Galuchat 5761 04	<b>British standard</b>	1 module	92 x 92
1	5761 23	5761 24		2 modules	92 x 92
1	5761 63	5761 64		3 modules	127 x 92
1	5761 83	5761 84		3 modules 1 gang horizontal and vertical mounting	92 x 92
1	5761 43	5761 44		4 modules	157 x 92
1	5763 73	5763 74		6 modules Supplied with support frame	237.5 x 92
1	5767 13	5767 14		8 modules Supplied with support frame	252.5 x 92
1	5762 13	5762 14		For 5 A and 13 A switched socket outlet 1 gang	92 x 92
1	5762 03	5762 04		For 13 A twin switched socket outlet 2 gang	157 x 92
1	5761 93	5761 94		For 13 A fused connection unit 1 gang	92 x 92

Pack	Cat. Nos.		Leather		Dimensions in mm
1	Club 5761 13	Galuchat 5761 14	<b>British standard</b>	2 modules	92 x 92
1	5761 53	5761 54		3 modules	127 x 92
1	5761 73	5761 74		3 modules 1 gang horizontal and vertical mounting	92 x 92
1	5761 33	5761 34		4 modules	157 x 92
1	5767 53	5767 54		6 modules Supplied with support frame	237.5 x 92
1	5766 93	5766 94		8 modules Supplied with support frame	252.5 x 92

## Arteor™ plates square version



5761 27



5761 87

Support frames and plates selection charts p. 134-137

## Arteor™ plates round version



5761 17



5761 77

Support frames and plates selection charts p. 134-137

Pack	Cat. Nos.	Signature	Dimensions in mm
1	Woven metal 5761 07	<b>British standard</b> 1 module	92 x 92
1	5761 27	2 modules	92 x 92
1	5761 67	3 modules	157 x 92
1	5761 87	3 modules 1 gang horizontal and vertical mounting	92 x 92
1	5761 47	4 modules	157 x 92
1	5763 77	6 modules Supplied with support frame	237.5 x 92
1	5767 17	8 modules Supplied with support frame	252.5 x 92
1	5762 17	For 5 A/13 A switched socket outlet - 1 gang	92 x 92
1	5762 07	For 13 A twin switched socket outlet - 2 gang	157 x 92
1	5761 97	For 13 A fused connection unit switched	92 x 92
1	5764 87	<b>Special plates</b> For video internal display unit 2.5", BUS alarm module and 3.5" touch screen	127 x 127
1	5765 17	For 10" multimedia touch screen	309 x 233
1	5765 37	For central unit for temperature control	165 x 176

Pack	Cat. Nos.	Signature	Dimensions in mm
1	Woven metal 5761 17	<b>British standard</b> 2 modules	92 x 92
1	5761 57	3 modules	157 x 92
1	5761 77	3 modules 1 gang horizontal and vertical mounting	92 x 92
1	5761 37	4 modules	157 x 92
2	5767 57	6 modules Supplied with support frame	237.5 x 92
2	5766 97	8 modules Supplied with support frame	252.5 x 92



# Synergy<sup>®</sup>

form and function  
in perfect harmony



Synergy White - slim faceplates with optional screw covers and triple indicator LEDs



Synergy Modern - slim contour faceplates with no visible screws and matching rockers



Whatever the application, residential or commercial, Synergy offers a great blend of style, choice and functionality, together with countless features designed to make the installer's life easier... form and function in perfect harmony

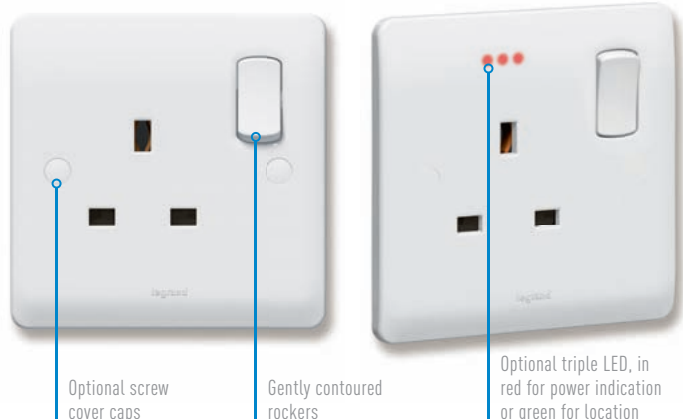

Optional screw cover caps

Gently contoured rockers

Optional triple LED, in red for power indication or green for location

## DESIGN THAT IS MUCH MORE THAN SKIN DEEP

Synergy's quality is reflected in everything from its components and design through to its ease of installation... including a complete range of compatible surface mounting boxes, compact mechanisms that maximise wiring space, large angled terminal entries with backed off screws and clear laser marking.

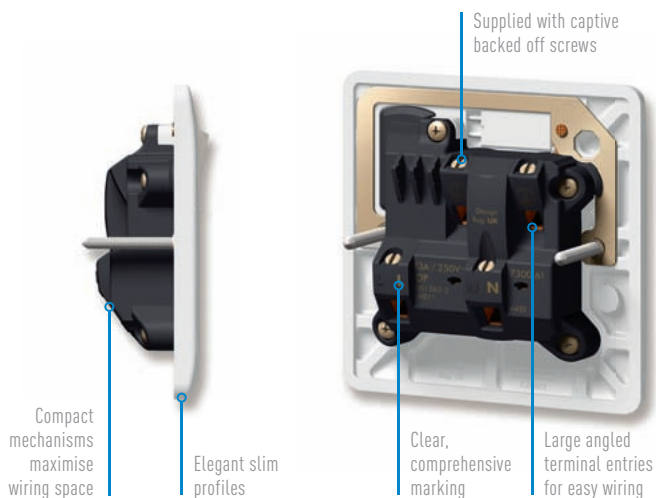

Compact mechanisms maximise wiring space

Elegant slim profiles

Supplied with captive backed off screws

Clear, comprehensive marking

Large angled terminal entries for easy wiring

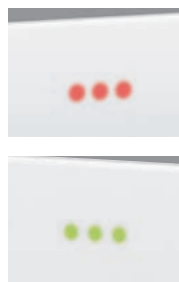

Just one of Synergy's unique features... optional triple LED packs provide location or power indication



Synergy Traditional - raised faceplates with visible screws and white rockers



Synergy Metalclad - unique clam-type fit



Synergy Grid - build your own system with a multitude of finishes and functions



# Synergy<sup>®</sup>

extending your choices  
through innovation

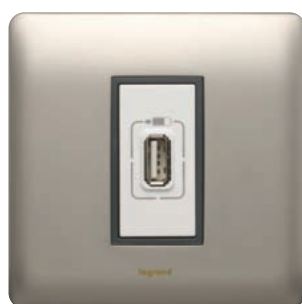

## ANYTHING IS POSSIBLE...

Integrate Synergy style with Arteor functionality to create an enhanced range of matching wiring accessories. With a wide selection of modular Arteor functions available (including international sockets, USB chargers, dimmers, wide rockers and thermostats) installations can be designed and adapted in line with end user requirements and future trends.



For Arteor modules  
see p. 111 - 131



# Don't just take our word for it



## Synergy installations far and wide...

Synergy wiring accessories have been installed in commercial and residential projects throughout the UK and ROI. Recent installations include:

The Savoy (hotel) - London  
 Radisson Blu (hotel) - East Midlands Airport  
 Adagio Aparthotel (hotel) - Liverpool

Co-op Headquarters (office) - Manchester  
 Morrisons (retail) - Yorkshire  
 Royal Infirmary (hospital) - Glasgow

## Synergy at The Savoy, London's grandest hotel

Legrand supplied a wide selection of Synergy wiring accessories for use in the ambitious restoration of the world famous hotel, The Savoy.

Bespoke wiring accessories from the Synergy range were used in all guestrooms throughout the hotel, with a range of products from our other divisions also contributing to the extensive renovation scheme.

## SPECIALIST APPLICATIONS

Legrand offers a variety of socket outlets and wide rocker switches, for specialist applications such as MEIGaN (Medical Electrical Installation Guidance Notes) and Part M of the Building Regulations.

















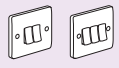
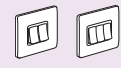











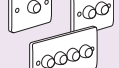
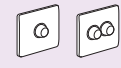

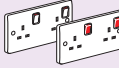

## BESPOKE SERVICE

Unique designs, colours to match any specification and special engraving...  
 Legrand's bespoke service turns the standard wiring accessory into a tailor-made solution.















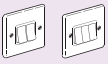
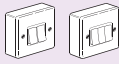
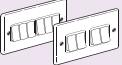

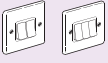

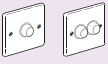
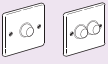
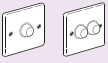
For bespoke solutions, contact us on +44 (0) 845 605 4333

# Synergy® functions and finishes

## selection chart

FUNCTIONS	WHITE		MODERN		
			Silver 	Nickel 	
<b>Switches</b>					
10 AX switch 1 x 1 way		7300 00		7310 00	7312 00
10 AX switch 1 x 2 way		7300 01		7310 01	7312 01
10 AX switch 1 x intermediate		7300 05		7310 05	7312 05
10 AX switch 2 x 2 way		7300 02		7310 02	7312 02
10 AX switch 3 x 2 way		7300 03		7310 03	7312 03
10 AX switch 4 x 2 way		7300 04		7310 04	7312 04
10 AX switch 6 x 2 way		7300 06		–	–
20 AX switch 1 x 1 way		7301 30		–	–
20 AX switch 1 x 2 way		7301 31		7311 31	7313 31
20 AX switch 2 x 2 way		7301 32		7311 32	7313 32
20 AX switch 3 x 2 way		7301 33		7311 33	7313 33
10 A 1 x 2 way push switch		7300 07		7310 07	7312 07
10 A 1 x 2 way push switch marked 'PRESS'		7300 11		–	–
10 AX switch - key 1 x 2 way		7300 08		–	–
10 A 3 pole fan switch		7300 09		7310 09	7312 09
<b>Dimmer units</b>					
Dimmer 1 x 2 way - 400 W push on/off rotary		7300 48		–	–
Dimmer 1 x 2 way LV - 250 W push on/off rotary		7300 46		7310 46	7312 46
Dimmer 2 x 2 way LV - 250 W push on/off rotary		7300 47		7310 47	7312 47
Dimmer - electronic 1 x 2 way - 400 W push on/off rotary		7301 56		7311 56	7313 56
Dimmer - electronic 2 x 2 way LV - 400 W push on/off rotary		7301 57		7311 57	7313 57
Dimmer - electronic 4 x 2 way LV - 400 W push on/off rotary		7300 49		–	–
<b>Socket outlets</b>					
Socket 13 A switched 1 gang DP		7300 60		7310 60	7312 60
Socket 13 A switched 1 gang DP with red rocker		7301 62		–	–
Socket 13 A switched 1 gang DP + indicator		7300 61		7310 61	7312 61
Socket 13 A switched 1 gang DP (clean earth)		7300 64		–	–
Socket 13 A switched 1 gang DP non-standard earth pin		7300 67		–	–
Socket 13 A switched 2 gang DP		7300 70		7310 70	7312 70
Socket 13 A switched 2 gang DP with red rockers		7301 61		–	–
Socket 13 A switched 2 gang DP + indicators		7300 71		7310 71	7312 71
Socket 13 A switched 2 gang outboard DP (clean earth)		7300 74		–	–
Socket 13 A switched 2 gang DP non-standard earth pin		7300 77		–	–
Socket 13 A switched 1 gang SP		7300 66		–	–
Socket 13 A switched 2 gang SP		7300 76		–	–
Socket 13 A unswitched 1 gang		7300 65		7310 65	7312 65
Socket 13 A unswitched 2 gang		7300 75		7310 75	7312 75
Socket 13 A 2 gang single socket with key switch		8200 74		–	–

See catalogue pages for full product specifications















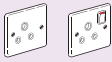
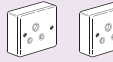
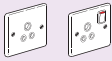

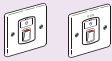
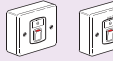







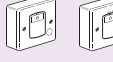

		TRADITIONAL		METALCLAD	
		Brushed stainless steel	Polished stainless steel		
					
		7330 00	7332 00		7338 00
		7330 01	7332 01		7338 01
		7330 05	7332 05		7338 05
		7330 02	7332 02		7338 02
		7330 03	7332 03		7338 03
		7330 04	7332 04		-
		7330 06	7332 06		-
		-	-		-
		7331 31	7333 31		-
		7331 32	7333 32		-
		7331 33	7333 33		-
		7330 07	7332 07		-
		-	-		-
		-	-		-
		7330 09	7332 09		-
		-	-		-
		7330 46	7332 46		-
		7330 47	7332 47		-
		7331 56	7333 56		-
		7331 57	7333 57		-
		-	-		-
		7330 60	7332 60		7338 60
		-	-		-
		7330 61	7332 61		7338 61
		-	-		-
		-	-		-
		7330 70	7332 70		7338 70
		-	-		-
		7330 71	7332 71		7338 71
		7330 74	7332 74		-
		-	-		-
		-	-		-
		7330 65	7332 65		7338 65
		7330 75	7332 75		7338 75
		8200 71	8200 72		8200 73

# Synergy® functions and finishes

selection chart (continued)



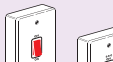









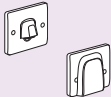
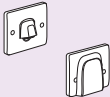
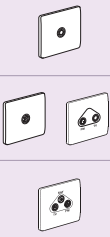
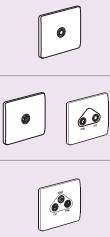

FUNCTIONS	WHITE		MODERN		
			Silver	Nickel	
RCD unit 2 gang DP 30 mA active		7300 97		7310 97	7312 97
RCD unit 2 gang DP 30 mA passive		7300 98		7310 98	7312 98
Socket 15 A unswitched		7300 88		7310 88	7312 88
Socket 15 A switched		7300 89		7310 89	7312 89
Socket 5 A unswitched		7300 68		7310 68	7312 68
Socket 5 A switched		7300 69		7310 69	7312 69
Socket 2 A unswitched		7300 59		7310 59	7312 59
Socket 16 A German 1 gang		7300 87		–	–
Shaver socket 240-115 V		7300 90		7310 90	7312 90
13 A FCU DP switched		7300 34		7310 34	7312 34
13 A FCU DP switched + indicator		7300 35		7310 35	7312 35
13 A FCU DP switched + cord outlet		7300 36		7310 36	7312 36
13 A FCU DP switched + cord outlet + indicator		7300 37		7310 37	7312 37
13 A FCU DP switched + deep plate + bottom cord outlet		7301 36		–	–
13 A FCU		7300 30		7310 30	7312 30
13 A FCU + power indicator		7300 31		7310 31	7312 31
13 A FCU + cord outlet		7300 32		7310 32	7312 32
13 A FCU + cord outlet + indicator		7300 33		7310 33	7312 33
20 A DP switch		7300 10		7310 10	7312 10
20 A DP switch marked 'WATER HEATER'		7301 10		–	–
20 A DP switch + cord outlet		7300 14		7310 14	7312 14
20 A DP switch + cord outlet marked 'WATER HEATER'		7301 14		–	–
20 A DP switch + cord outlet + indicator		7300 16		7310 16	7312 16
20 A DP switch + cord outlet + indicator marked 'WATER HEATER'		7301 16		–	–
20 A DP switch + indicator		7300 12		7310 12	7312 12
20 A DP switch + indicator marked 'WATER HEATER'		7301 12		–	–
20 A sink/bath dual switch + indicator		7300 18		–	–
45 A DP switch 146 x 86		7300 20		–	–
45 A DP switch 146 x 86 + red rocker		7301 20		–	–
45 A DP switch 146 x 86 + indicator		7300 21		–	–
45 A DP switch 146 x 86 + red rocker + indicator		–		7310 21	7312 21
45 A DP switch 86 x 86		7300 22		–	–
45 A DP switch 86 x 86 + red rocker		7301 22		7310 22	7312 22
45 A DP switch 86 x 86 + indicator		7300 23		–	–
45 A DP switch 86 x 86 + red rocker + indicator		–		7310 23	7312 23

See catalogue pages for full product specifications

		TRADITIONAL		METALCLAD	
		Brushed stainless steel	Polished stainless steel		
					
		7330 97	7332 97		7338 97
		7330 98	7332 98		7338 98
		7330 88	7332 88		7338 88
		7330 89	7332 89		7338 89
		7330 68	7332 68		-
		7330 69	7332 69		-
		7330 59	7332 59		-
		-	-		-
		7330 90	7332 90		-
		7330 34	7332 34		7338 34
		7330 35	7332 35		7338 35
		7330 36	7332 36		7338 36
		7330 37	7332 37		7338 37
		-	-		-
		7330 30	7332 30		7338 30
		7330 31	7332 31		7338 31
		7330 32	7332 32		7338 32
		7330 33	7332 33		733833
		7330 10	7332 10		7338 10
		-	-		-
		7330 14	7332 14		7338 14
		-	-		-
		7330 16	7332 16		7338 16
		-	-		-
		7330 12	7332 12		7338 12
		-	-		-
		-	-		-
		7330 20	7332 20		7338 20
		-	-		-
		7330 21	7332 21		7338 21
		-	-		-
		7330 22	7332 22		-
		-	-		-
		7330 23	7332 23		-

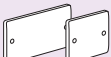
## Synergy® functions and finishes

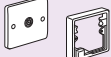
selection chart (continued)

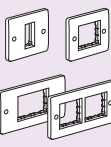
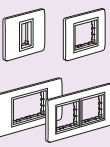
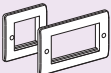
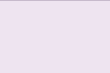
FUNCTIONS	WHITE		MODERN		
			Silver 	Nickel 	
<b>Cooker control units</b>					
Cooker unit DP switch with DP switched socket		7300 28		–	–
Cooker unit DP switch with DP switched socket + indicator		7300 29		7310 29	7312 29
<b>Cable outlets</b>					
Cable outlet 20 A terminal block		7300 19		7310 19	7312 19
Cable outlet 45 A terminal block		7300 26		7310 26	7312 26
<b>TV, radio and satellite sockets</b>					
Screened TV single male		7300 40		7310 40	7312 40
Screened TV single female		7301 40		–	–
Screened satellite		7300 41		7310 41	7312 41
Screened TV/FM		7300 42		7310 42	7312 42
Screened TV/FM/satellite		7300 43		7310 43	7312 43
Quad outlet TV/FM / 2 x Satellite/TV return/phone		7300 45 <sup>1</sup>		7310 45	7312 45
<b>Telephone sockets</b>					
Telephone socket single master		7300 50 <sup>1</sup>		7310 50 <sup>1</sup>	7312 50 <sup>1</sup>
Telephone socket single secondary		7300 51 <sup>1</sup>		7310 51 <sup>1</sup>	7312 51 <sup>1</sup>
Telephone socket RJ11/12 single		7300 54		7310 54	7312 54
<b>Data sockets</b>					
Data outlet RJ45 single - CAT 6 UTP		7300 56		7310 56	7312 56
Data outlet RJ45 double - CAT 6 UTP		7300 57		7310 57	7312 57
<b>Media plates</b>					
Media plates (monobloc)		8201 42		8201 46	8201 45
<b>Accessories</b>					
Blanking plate 1 gang		7300 95		7310 95	7312 95
Blanking plate 2 gang		7300 96		7310 96	7312 96
Outlet plate 1 gang		7300 52		7310 52	7312 52
Cord outlet accessory box		7300 53		–	–
Spacer frame 1 gang		7301 95		–	–
Spacer frame 2 gang		7301 96		–	–
<b>Carrier plates</b>					
Carrier plate 1 gang 1 Arteor module		7300 91		7310 91	7312 91
Carrier plate 1 gang 2 Arteor modules		7300 92		7310 92	7312 92
Carrier plate 2 gang 3 Arteor modules		7300 93		7310 93	7312 93
Carrier plate 2 gang 4 Arteor modules		7300 94		7310 94	7312 94
<b>Euro module plates</b>					
1 gang 2 Arteor modules		7300 99		–	–
2 gang 4 Arteor modules		7301 00		–	–

See catalogue pages for full product specifications

1 : Not suitable for use in the ROI

		TRADITIONAL		METALCLAD	
		Brushed stainless steel	Polished stainless steel		
					
	7330 28	7332 28	-		
	7330 29	7332 29	-		
	7330 19	7332 19		7338 19	
	7330 26	7332 26		-	
	7330 40	7332 40		7338 40	
	-	-		-	
	7330 41	7332 41		7338 41	
	7330 42	7332 42		-	
	7330 43	7332 43		-	
	7330 45	7332 45		-	
	7330 50 <sup>1</sup>	7332 50 <sup>1</sup>		7338 50 <sup>1</sup>	
	7330 51 <sup>1</sup>	7332 51 <sup>1</sup>		7338 51 <sup>1</sup>	
	7330 54	7332 54		-	
	7330 56	7332 56		7338 56	
	7330 57	7332 57		7338 57	
	8201 43	8201 44		-	
	7330 95	7332 95		7338 95	
	7330 96	7332 96		7338 96	
	7330 52	7332 52		-	
	-	-		-	
	-	-		-	
	-	-		-	
	7330 91	7332 91		7338 91	
	7330 92	7332 92		7338 92	
	7330 93	7332 93		7338 93	
	7330 94	7332 94		7338 94	
	-	-		-	
	-	-		-	

# Synergy® carrier plates

for Arteor modules

		FRONT PLATES FOR ARTEOR MODULES											
		1 gang		1 gang		2 gang		2 gang		2 x 2 gang		3 x 3 gang	
<b>FRONT PLATES</b>		Clip-in carrier plate - no yoke required								Yoke required			
		Pack	<b>1 module</b>	Pack	<b>2 modules</b>	Pack	<b>3 modules</b>	Pack	<b>4 modules</b>	Pack	<b>8 modules</b>	Pack	<b>18 modules</b>
<b>Dimensions (mm)</b>		<b>86 x 86</b>		<b>86 x 86</b>		<b>86 x 146</b>		<b>86 x 146</b>		<b>146 x 146</b>		<b>267 x 206</b>	
<b>White</b>		10	7300 91	10	7300 92	10	7300 93	10	7300 94	1	7301 88	1	7301 90
<b>Traditional brushed stainless steel</b>		1	7330 91	1	7330 92	1	7330 93	1	7330 94	1	7331 88	1	7331 90
<b>Traditional polished stainless steel</b>		1	7332 91	1	7332 92	1	7332 93	1	7332 94	1	7333 88	1	7333 90
<b>Metalclad</b>		5	7338 91 <sup>1</sup>	5	7338 92 <sup>1</sup>	5	7338 93 <sup>1</sup>	5	7338 94 <sup>1</sup>	1	7339 88	1	7339 90
<b>Dimensions (mm)</b>		<b>89 x 89<sup>2</sup></b>		<b>89 x 89<sup>2</sup></b>		<b>89 x 149<sup>2</sup></b>		<b>89 x 149<sup>2</sup></b>		<b>146 x 146</b>		<b>267 x 206</b>	
<b>Modern silver</b>		1	7310 91	1	7310 92	1	7310 93	1	7310 94	1	7311 88	1	7311 90
<b>Modern nickel</b>		1	7312 91	1	7312 92	1	7312 93	1	7312 94	1	7313 88	1	7313 90
<b>GRID YOKES for 2 x 2 and 3 x 3 gang front plates</b>													
<b>Grid yoke complete with Arteor module carrier</b>													
		-	-	-	-	-	-	-	-	1	2 x 7354 74	1	3 x 7354 76
<b>BACK BOXES</b>													
<b>FLUSH MOUNTING</b>													
<b>Dimensions (mm)</b>		<b>35 mm depth</b>		<b>35 mm depth</b>		<b>35 mm depth</b>		<b>35 mm depth</b>		<b>137 x 137 x 43</b>		<b>254 x 194 x 56</b>	
<b>Flush</b>		50	0891 13	50	0891 13	40	0891 14	40	0891 14	1	0818 52	1	0818 54
<b>Flush with phase barriers</b>		-	-	-	-	-	-	-	-	-	-	1	0818 58
<b>SURFACE MOUNTING</b>													
<b>Dimensions (mm)</b>		<b>86 x 86 x 47</b>		<b>86 x 86 x 47</b>		<b>86 x 146 x 47</b>		<b>86 x 146 x 47</b>					
<b>Surface white for white only</b>		10	7364 07	10	7364 07	5	7364 11	5	7364 11	-		-	
<b>Dimensions (mm)</b>		<b>86 x 86 x 37</b>		<b>86 x 86 x 37</b>		<b>86 x 146 x 37</b>		<b>146 x 146 x 37</b>		<b>146 x 146 x 37</b>			
<b>Surface steel with knockouts</b>		10	7364 00	10	7364 00	5	7364 01	5	7364 01	1	7364 18	-	
<b>Surface steel without knockouts</b>		10	7364 20	10	7364 20	5	7364 21	5	7364 21	1	7364 22	-	
		<b>Arteor mechanisms</b> (p. 111-131)											

**Front plate material**

**White** : 1 to 4 modules - thermoset; 8-18 modules - stainless steel  
**Traditional** : All modules - stainless steel  
**Metalclad** : 1 to 4 modules - mild steel; 8 to 18 modules - stainless steel  
**Modern** : 1 to 4 modules - die cast alloy; 8 to 18 modules - stainless steel

1 : Supplied with back box  
 2 : Screw free clip-on front plate  
 3 : Phase barrier variant shown



# Synergy® white switches



7300 00



7300 02



7300 00 + optional locator LED (Cat. No. 7301 58)



7300 07

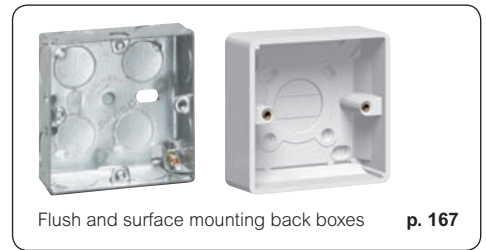

Flush and surface mounting back boxes

p. 167



7301 33



7300 06



7300 08



7300 09



7300 09 + optional screw caps (included)

Front plates : white thermoset  
Terminal screws captive and backed off ready for cabling  
Supplied with optional faceplate screw caps

Pack	Cat. Nos.	Single pole plate switches 10 AX - 250 V~
		Conform to BS EN 60669-1 : 2000 Optional Red LED 'power on' indicator and green LED 'locator' upgrade packs available Flush mounting back box : min. 16 mm deep Nominal plate dimensions : 1, 2 and 3 gang - 86 x 86 mm 4 and 6 gang - 86 x 146 mm
10	7300 00	1 gang - 1 way
10	7300 01	1 gang - 2 way
10	7300 05	1 gang - intermediate
10	7300 02	2 gang - 2 way
10	7300 03	3 gang - 2 way
5	7300 04	4 gang - 2 way
5	7300 06	6 gang - 2 way

Pack	Cat. Nos.	Single pole plate switches 20 AX - 250 V~
		Conform to BS EN 60669-1 : 2000 Optional Red LED 'power on' indicator and green LED 'locator' upgrade packs available Flush mounting back box : min. 25 mm deep Nominal plate dimensions : 86 x 86 mm
10	7301 30	1 gang - 1 way
10	7301 31	1 gang - 2 way
10	7301 32	2 gang - 2 way
10	7301 33	3 gang - 2 way

Pack	Cat. Nos.	Single pole push switches 10 A - 250 V~
		Conform to BS EN 60669-1 : 2000 Optional Red LED 'power on' indicator and green LED 'locator' upgrade packs available Flush mounting back box : min. 16 mm deep Nominal plate dimensions : 86 x 86 mm
5	7300 07	1 gang - 2 way push switch
5	7300 11	1 gang - 2 way push switch marked "PRESS"
		<b>Single pole key switch 10 AX - 250 V~</b>
		Conforms to BS EN 60669-1 : 2000 Optional Red LED 'power on' indicator and green LED 'locator' upgrade packs available Key supplied Flush mounting back box : min. 16 mm deep Nominal plate dimensions : 86 x 86 mm
10	7300 08	1 gang - 2 way
5	0811 77	Spare key for above

Pack	Cat. Nos.	3 pole fan switch 10 A - 250 V~
		Conforms to BS EN 60669-1 : 2000 With integrated padlockable safety block in OFF position Flush mounting back box : min. 25 mm deep Nominal plate dimensions : 86 x 86 mm
10	7300 09	3 pole fan switch

**For green locator LED pack or red power indicator LED pack, see p. 166**

**For green locator LED pack or red power indicator LED pack, see p. 166**

# Synergy® white dimmers



7300 46



7300 47



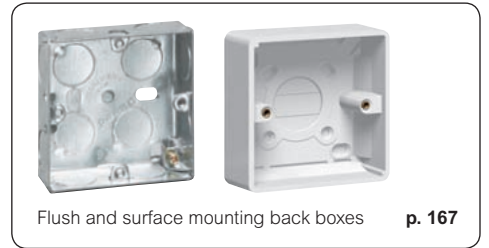

7300 49





Flush and surface mounting back boxes

p. 167

Front plates : white thermoset  
Terminal screws captive and backed off ready for cabling  
Supplied with faceplate screw caps

Pack	Cat. Nos.	Dimmer units - 230 V~
1	7300 48	<p>Conform to BS EN 60669-2-1 : 2000 and BS EN 55015</p> <p>Rotary dimming and push on/off For use with 230 V AC Not suitable for fluorescent load Flush mounting back box : min. 25 mm deep Nominal plate dimensions : 86 x 86 mm</p> <p>Dimmers for use with tungsten filament lamps and good quality GU10 halogen lamps</p> <p> 1 gang – 2 way 50 Hz 60 W-400 W push on/off rotary</p> <p>Dimmers for use with tungsten filament lamps, GU10 halogen lamps and low voltage systems using appropriate transformer</p>
1	7300 46	<p> 1 gang – 2 way 50 Hz 40 W-250 W push on/off rotary</p>
1	7300 47	<p> 2 gang – 2 way 50 Hz 40 W-250 W push on/off rotary</p>

Pack	Cat. Nos.	Dimmer units - 230 V~ - electronic type
1	7301 56	<p>Conform to BS EN 60669-2-1 : 2000 and BS EN 55015</p> <p>Rotary dimming and push on/off For use with 230 V AC - 50-60 Hz Not suitable for fluorescent load Flush mounting back box : min. 25 mm deep</p> <p>Dimmers for use with tungsten filament lamps, good quality wire-wound transformers for low voltage loads</p> <p>Nominal plate dimensions : 86 x 86 mm</p> <p> 1 gang – 2 way 50 Hz 40 W-400 W push on/off rotary</p>
1	7301 57	<p> 2 gang – 2 way 50 Hz 40 W-400 W push on/off rotary</p> <p>Nominal plate dimensions : 86 x 146 mm</p>
1	7300 49	<p> 4 gang – 2 way 50 Hz 40 W-400 W push on/off rotary</p>

**For non-rotary dimmers, use Arteor modules with Synergy carrier plates**  
(p. 115 and 158 respectively)

# Synergy® white socket outlets



7300 60



7300 70



7300 66

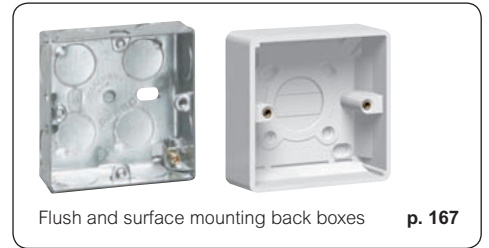

Flush and surface mounting back boxes

p. 167



7301 62



7300 74



6745 32



7300 76



7300 65

Front plates : white thermoset  
Terminal screws captive and backed off ready for cabling  
Supplied with optional faceplate screw caps

Pack	Cat. Nos.	Double pole socket outlets 13 A - 250 V~
		Conform to BS 1363 - Part 2 : 1995 Options available as standard with red 'power on' LED indicator Red LED 'power on' upgrade pack also available 2 earth terminals Flush mounting back box : min. 25 mm deep Nominal plate dimensions : 1 gang - 86 x 86 mm 2 gang - 86 x 146 mm
10	7300 60	1 gang – switched
10	7301 62	1 gang – switched with red rocker
10	7300 61	1 gang – switched with red LED power indicator
10	7300 64	1 gang – switched for standard and clean earth applications
10	7300 67	1 gang – switched non-standard earth pin for standard and clean earth applications
5	7300 70	2 gang – switched
5	7301 61	2 gang – switched with red rocker
5	7300 71	2 gang – switched with red LED power indicator
5	7300 74	2 gang – switched outboard for standard and clean earth applications
5	7300 77	2 gang – switched non-standard earth pin for standard and clean earth applications

Pack	Cat. Nos.	13 A non-standard earth pin plug
20	6745 32	2 P + E non-standard round earth pin

For green locator LED pack or red power indicator LED pack, see p. 166

Pack	Cat. Nos.	Single pole socket outlets 13 A - 250 V~
		Conform to BS 1363 - Part 2 : 1995 Options available as standard with red 'power on' LED indicator Red LED 'power on' upgrade pack also available Conventional earth pin release shutter Single earth terminal Flush mounting back box : min. 25 mm deep Nominal plate dimensions : 1 gang - 86 x 86 mm 2 gang - 86 x 146 mm
10	7300 66	1 gang – switched
5	7300 76	2 gang – switched
		<b>Unswitched and key switched socket outlets 13 A - 250 V~</b> Conform to BS 1363 - Part 2 : 1995 Optional red LED 'power on' upgrade pack available (not applicable to key switched sockets) 2 earth terminals Flush mounting back box : min. 25 mm deep Nominal plate dimensions : 1 gang - 86 x 86 mm 2 gang - 86 x 146 mm
10	7300 65	1 gang – unswitched
5	7300 75	2 gang – unswitched
1	8200 74	2 gang single socket with DP key switch <sup>(1)</sup>

For green locator LED pack or red power indicator LED pack, see p. 166

1 : Flush mounting back box : min. 35 mm deep

# Synergy® white

## socket outlets (continued)



Front plates : white thermoset  
Terminal screws captive and backed off ready for cabling  
Supplied with faceplate screw caps

Pack	Cat. Nos.	Shaver socket
1	7300 90	<p>Conforms to BS EN 61558-2-5 : 1998 IP 24</p> <p>For use with European, British, American and Australian 2 pin plugs Screwless live and neutral terminals Double wound isolating transformer Automatic self-resetting overload feature Plug insertion operates microswitch which energises transformer Flush mounting back box : min. 47 mm deep Nominal plate dimensions : 146 x 86 mm</p> <p>Supply : 230 V - 50/60 Hz Output : 230/120 V - 20 VA max.</p>

Pack	Cat. Nos.	RCD sockets 13 A - 250 V~
1	7300 97	<p>Conform to BS 7288 : 1990 and BS 1363 - Part 2 : 1995</p> <p>Terminal screws captive and backed off ready for cabling Conventional earth pin release shutter Maximum operating current 16 A Incorporate a "test and reset" button Flush mounting back box : min. 25 mm deep Nominal plate dimensions : 86 x 146 mm</p> <p><b>Active (electronically latched)</b> - trips in the event of a power failure - suitable in applications where automatic restoration of supply would be hazardous, e.g. machinery, power tools</p> <p>RCD unit 2 gang DP 30 mA active</p>
1	7300 98	<p><b>Passive (mechanically latched)</b> - does not trip in the event of a power failure - suitable in applications where automatic restoration of supply is required, e.g. fridge, freezer, unmanned areas</p> <p>RCD unit 2 gang DP 30 mA passive</p>

Pack	Cat. Nos.	Socket outlets 15 A - 250 V~
10	7300 88	<p>Conform to BS 546 : 1950 Optional red LED 'power on' upgrade pack available Flush mounting back box : min. 35 mm deep Nominal plate dimensions : 86 x 86 mm</p> <p>1 gang - unswitched</p>
10	7300 89	<p>1 gang - switched</p>

Pack	Cat. Nos.	Socket outlets 5 A - 250 V~
10	7300 68	<p>Conform to BS 546 : 1950 Optional red LED 'power on' upgrade pack available 2 earth terminals Flush mounting back box : min. 25 mm deep Nominal plate dimensions : 86 x 86 mm</p> <p>1 gang - unswitched</p>
10	7300 69	<p>1 gang - switched</p>

Pack	Cat. Nos.	Socket outlet 2 A - 250 V~
10	7300 59	<p>Conforms to BS 546 : 1950 Optional red LED 'power on' upgrade pack available Conventional earth pin shutter release Flush mounting back box : min. 25 mm deep Nominal plate dimensions : 86 x 86 mm</p> <p>1 gang - unswitched</p>

Pack	Cat. Nos.	Socket outlet 10/16 A - 250 V~ German
10	7300 87	<p>Conforms to IEC 60884-1 : 2002 Optional red LED 'power on' upgrade pack available Flush mounting back box : min. 47 mm deep Nominal plate dimensions : 86 x 86 mm</p> <p>1 gang - unswitched</p>

For red power indicator LED pack, see p. 166

# Synergy® white

## fused connection units



7300 34



7300 30



7300 36



7300 33

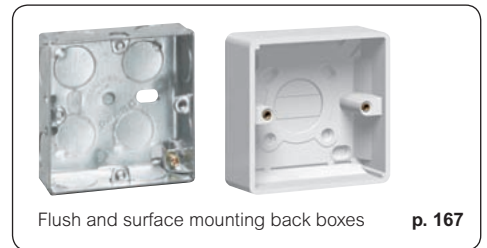

Flush and surface mounting back boxes

p. 167



TOWEL RAIL

Bespoke and standard engraving available p. 169

Front plates : white thermoset  
Terminal screws captive and backed off ready for cabling<sup>(1)</sup>  
Supplied with faceplate screw caps

Pack	Cat. Nos.	Fused connection units 13 A - 250 V~
		Conform to BS 1363 - Part 4 : 1995 Options available as standard with red 'power on' LED indicator LED 'power on' upgrade pack also available Fused 13 A (fuse supplied) Fuse drawer retained by quarter turn catch, drawer padlockable in open position for safety To obtain flush to wall external cord connection on standard depth Cat. Nos. use cord outlet accessory box Cat. No. 7300 53 (see p. 166) Flush mounting back box : min. 25 mm deep Nominal plate dimensions : 86 x 86 mm
		<b>Switched</b>
10	7300 34	Switched, DP
10	7300 35	Switched, DP with red LED power indicator
10	7300 36	Switched, DP with cord outlet
10	7300 37	Switched, DP with cord outlet + red LED power indicator
10	7301 36	Switched, DP - deep plate with bottom cord outlet <sup>1</sup>

**For red power indicator LED pack, see p. 166**

Pack	Cat. Nos.	Fused connection units 13 A - 250 V~ (continued)
		<b>Unswitched</b>
10	7300 30	Unswitched
10	7300 31	Unswitched with red LED power indicator
10	7300 32	Unswitched with cord outlet
10	7300 33	Unswitched with cord outlet + red LED power indicator

**For red power indicator LED pack, see p. 166**

1 : For 13 A switched sockets with matching depth faceplate, see p. 162

# Synergy® white control switches



7300 10



7301 10



7300 18



7300 19



7301 20



7300 23

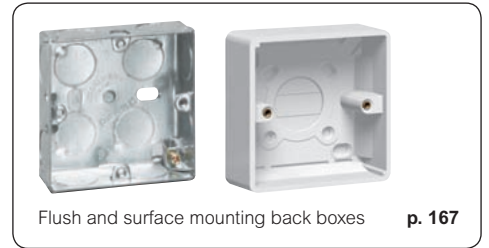

Flush and surface mounting back boxes

p. 167



7300 29

Front plates : white thermoset  
Terminal screws captive and backed off ready for cabling  
Supplied with faceplate screw caps

Pack	Cat. Nos.	Double pole switches 20 A - 250 V <sup>1</sup>
		Conform to BS EN 60669-1 : 2000 Options available as standard with red 'power on' LED indicator LED 'power on' upgrade pack also available Use cord outlet accessory box Cat. No. 7300 53 for flush to wall external cord connection, (see p.166) Flush mounting back box : min. 25 mm deep Nominal plate dimensions : 86 x 86 mm
10	7300 10	20 A DP
10	7301 10	20 A DP marked "WATER HEATER"
10	7300 14	20 A DP with cord outlet
10	7301 14	20 A DP with cord outlet marked "WATER HEATER"
10	7300 16	20 A DP with cord outlet + red LED power indicator
10	7301 16	20 A DP with cord outlet marked "WATER HEATER" + red LED power indicator
10	7300 12	20 A DP + red LED power indicator
10	7301 12	20 A DP marked "WATER HEATER" + red LED power indicator
10	7300 18	20 A sink/bath dual switch + red LED power indicator

Pack	Cat. Nos.	Cable outlet 20 A - 250 V <sup>~</sup>
		Conforms to BS 5733 : 1995 Flush mounting back box : min. 25 mm deep Nominal plate dimensions : 86 x 86 mm
10	7300 19	20 A – with terminal block and outlet gland

For red power indicator LED pack, see p. 166

1 : Range of engraving available on most products, see table on p. 169

Pack	Cat. Nos.	Double pole switches 45 A - 250 V <sup>~</sup>
		Conform to BS EN 60669-1 : 2000 Options available as standard with red 'power on' LED indicator LED 'power on' upgrade pack also available Flush mounting back box : min. 48 mm deep Nominal plate dimensions : 2 gang - 146 x 86 mm 1 gang - 86 x 86 mm
5	7300 20	45 A DP
5	7301 20	45 A DP with red rocker marked "COOKER"
5	7300 21	45 A DP + red LED power indicator
10	7300 22	45 A DP
10	7301 22	45 A DP with red rocker marked "COOKER"
10	7300 23	45 A DP + red LED power indicator

Pack	Cat. Nos.	Cooker control units 45 A - 250 V <sup>~</sup>
		Conform to BS 4177 : 1992 Options available as standard with red 'power on' LED indicator LED 'power on' upgrade pack also available 45 A - 250 V <sup>~</sup> double pole switch with 13 A - 250 V <sup>~</sup> double pole switched socket outlet Flush mounting back box : min. 48 mm deep Nominal plate dimensions : 86 x 146 mm
5	7300 28	DP with DP switched socket
5	7300 29	DP with DP switched socket + red LED power indicator

Pack	Cat. Nos.	Cable outlet 45 A - 250 V <sup>~</sup>
		Conforms to BS 5733 : 1995 2 piece design for safety Flush mounting back box : min. 48 mm deep Nominal plate dimensions : 86 x 86 mm
5	7300 26	45 A – with terminal block

# Synergy® white

## TV, telephone and data sockets

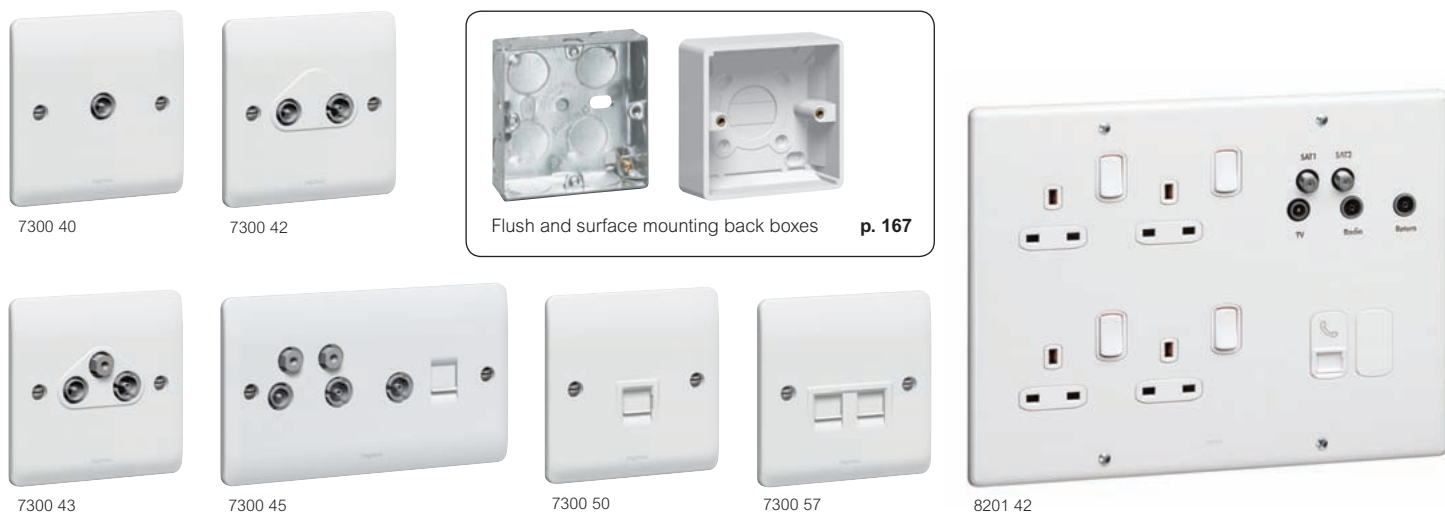

Front plates : white thermoset  
Supplied with faceplate screw caps

Pack	Cat. Nos.	TV, radio and satellite sockets
		Flush mounting back box : min. 35 mm deep Nominal plate dimensions : 1 gang - 86 x 86 mm 2 gang - 86 x 146 mm
10	7300 40	Screened TV – single, male Non-isolated
10	7301 40	Screened TV – single, female Non-isolated
1	7300 41	Screened satellite – single, 'F' type
10	7300 42	Screened TV + FM Isolated
1	7300 43	Screened TV + FM + satellite, 'F' type
1	7300 45 <sup>1</sup>	Quad outlet, TV, radio + 2 satellite + TV return with secondary telephone outlet

Pack	Cat. Nos.	Telephone sockets
		Shuttered Flush mounting back box : min. 35 mm deep Nominal plate dimensions : 86 x 86 mm
10	7300 50 <sup>1</sup>	Single master
10	7300 51 <sup>1</sup>	Single secondary
10	7300 54	Single RJ11/12

Pack	Cat. Nos.	Data sockets
		CAT 6 compliant UTP Rapid cable connection Flush mounting back box : min. 35 mm deep Nominal plate dimensions : 86 x 86 mm
1	7300 56	RJ45 – single
1	7300 57	RJ45 – double
		<b>Also available :</b> Euro module plates for 25 x 50 mm data modules, see p. 166

Pack	Cat. Nos.	Media plate (monobloc)
		Comprising 2 x independent satellite feeds, 1 x terrestrial TV socket suitable for analogue and digital signals, 1 x video return, 1 x secondary telephone point, 2 x Synergy 2 gang switched DP 13 A sockets To be used with back box Cat. No. 8204 58 below Dimensions : 206 x 267 mm Material : stainless steel
1	8201 42	White (metal)

Pack	Cat. Nos.	Back box for media plate
		Dimensions : 194 x 254 x 35 mm With phase barrier Material : grey epoxy coated steel
1	8204 58	35 mm deep box

1 : Not suitable for use in the ROI

# Synergy® white accessories



Pack	Cat. Nos.	Accessories
<b>Blanking plates</b>		
10	7300 95	1 gang - 86 x 86 mm
10	7300 96	2 gang - 86 x 146 mm
<b>LED packs</b>		
Relevant Synergy functions are designed to accept the LED packs for fitting at time of installation or retrospectively by a qualified person Compatible with fluorescent loads		
10	7301 58	Electronic LED locator pack – green diodes : max. current 0.2 mA provides illumination to locate function such as switches in low light
10	7300 58	Electronic LED power indicator pack – red diodes : nominal current 2 mA provides indication of 'power on' condition in such functions as sockets and control switches
<b>Outlet plate - VDI/low voltage</b>		
10	7300 52	1 gang - 86 x 86 mm with cable clamp and outlet gland
<b>Contrast frames</b>		
Aid Part M compliance when using Synergy White wiring accessories		
10	8218 46	1 gang contrast frame
10	8218 47	2 gang contrast frame
<b>Accessory frames</b>		
10	7300 53	1 gang - 86 x 86 x 11 mm with bottom cord outlet For flush to wall external cord connection suitable for use with 13 A and 20 A control switches and other relevant 86 x 86 mm functions Integral cord grip
10	7301 95	1 gang - 86 x 86 x 7 mm spacer frame
5	7301 96	2 gang - 86 x 146 x 7 mm spacer frame
<b>Spare screw cap covers</b>		
10	7301 53	Pack of 50 caps to cover mounting screws

Pack	Cat. Nos.	Accessories
Grid selection charts <b>p. 194-195</b> Grid modules <b>p. 190-192</b> Arteor modules <b>p. 111-131</b>		
<b>Euro module front plates</b>		
Suitable for use with standard 25 x 50 mm euro data module inserts		
10	7300 99	1 gang - 86 x 86 mm
10	7301 00	2 modules - aperture size 50 x 50 mm
<b>Carrier plates for Arteor modules (square)</b>		
No additional yoke required Enable a Synergy installation to benefit from the additional functionality of Arteor, such as international sockets etc		
10	7300 91	1 gang - 86 x 86 mm 1 Arteor module
10	7300 92	1 gang - 86 x 86 mm 2 Arteor modules
10	7300 93	2 gang - 86 x 146 mm 3 Arteor modules
10	7300 94	2 gang - 86 x 146 mm 4 Arteor modules
<b>1 and 2 gang front plates for grid modules</b>		
Must be used with yokes, see below		
10	7301 91	1 gang - 86 x 86 mm 1 small aperture module
10	7301 92	1 gang - 86 x 86 mm 2 small aperture modules
10	7301 93	2 gang - 86 x 146 mm 3 small aperture modules
10	7301 94	2 gang - 86 x 146 mm 4 small aperture modules
<b>1 and 2 gang yokes for grid modules</b>		
10	7354 90	1 gang 1 module
10	7354 91	1 gang 2 modules
10	7354 92	2 gang 3/4 modules



## surface mounting moulded back boxes



7364 06



7364 07

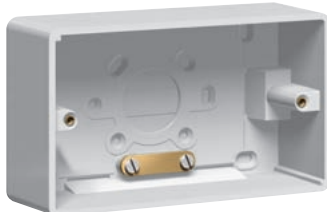

7364 11

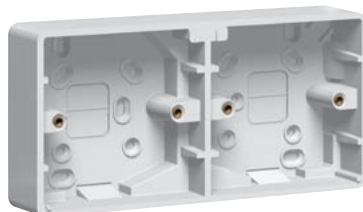

7364 13

## flush mounting steel back boxes



0891 10



0891 13



0891 11

### Pack Cat. Nos. Surface mounting moulded boxes - thermoset

Conform to BS 5733  
Material : white thermoset  
Mini trunking knockouts located around periphery of boxes

Dimensions : 1 gang - 87 x 87 mm  
2 gang - 87 x 147 mm

#### Depth 16 mm

10 7364 03  1 gang  
With earth terminal

#### Depth 35 mm

10 7364 06  1 gang

5 7364 10  2 gang

5 7364 13  2 x 1 gang

#### Depth 47 mm

10 7364 07  1 gang

5 7364 11  2 gang

### Architrave back boxes

#### Depth 30 mm

10 7364 05  Dimensions : 86 x 36 mm

5 7364 04  Dimensions : 146 x 36 mm

### Pack Cat. Nos. Flush mounting back boxes - steel

Conform to BS 4662  
Material : galvanised steel  
Top, side and back knockout entries according to type of box

#### Depth 16 mm

100 0891 09  1 gang with 1 fixed lug, 1 adjustable lug and 1 earth terminal

#### Depth 25 mm

50 0891 10  1 gang with 3 fixed lugs, 1 adjustable lug and 1 earth terminal

10 0891 11  2 gang with 1 fixed lug, 1 adjustable lug and 1 earth terminal

#### Depth 35 mm

50 0891 13  1 gang with 3 fixed lugs, 1 adjustable lug and 1 earth terminal

40 0891 14  2 gang with 1 fixed lug, 1 adjustable lug and 1 earth terminal

40 0891 40  Dual box with 2 earth terminals  
Accepts 2 single gang accessories

#### Depth 48 mm

25 0891 17  1 gang with 3 fixed lugs, 1 adjustable lug and 1 earth terminal

20 0891 18  2 gang with 1 fixed lug, 1 adjustable lug and 1 earth terminal

### Architrave back boxes

#### Depth 26 mm

5 7364 40  Dimensions : 82 x 28 mm

5 7364 41  Dimensions : 142 x 28 mm

# Synergy® white

## ■ LED power and locator indicators

Power indicator Cat. No. 7300 58 (red) and locator indicator Cat. No. 7301 58 (green)

These LED packs can be fitted as an option to a range of Synergy White functions including :

- 10 A switches 1 gang
- 5 A, 13 A and 15 A socket outlets
- 13 A connection units
- 20 A and 45 A double pole control switches

The LED packs are wired in alternative ways for different functionality. Factory fitted LEDs can be re-configured on site

## ■ Sample wiring schemes

### Switch 10 A

Green LED locator

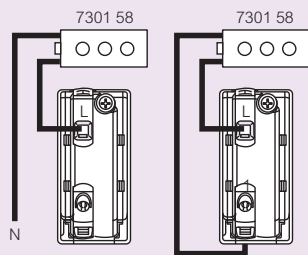

Red LED power indicator

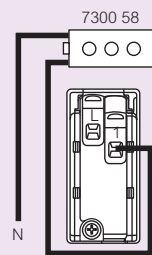

### Socket 13 A switched

Green LED locator

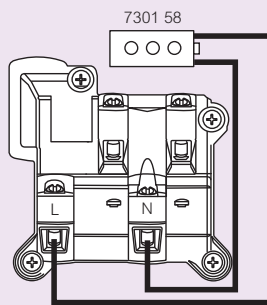

Red LED power indicator

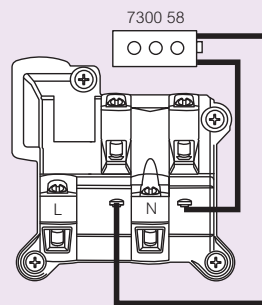

### Socket 13 A unswitched

Green LED locator

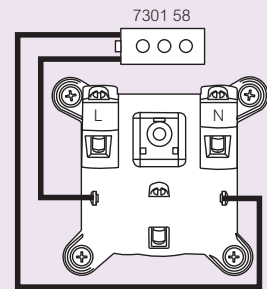

## ■ Cable outlet options : 13 A connection units and 20 A double pole control switches

These devices are available in three cable outlet variants :

- Without provision for an external cable outlet (i.e. for internal cabling)
- With a cable outlet in the front plate supplied with an integral screw type cable clamp and outlet cover plug
- With a bottom cord outlet on a deep plate

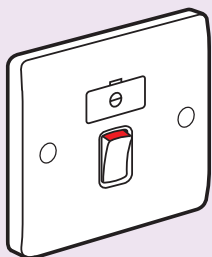

13 A fused connection unit  
no external cable outlet

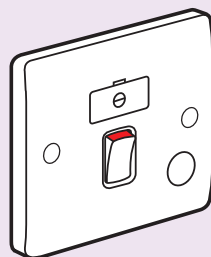

13 A fused connection unit  
with front cable outlet

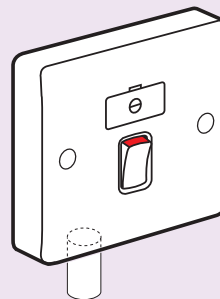

13 A fused connection unit  
with deep plate and bottom  
cable outlet

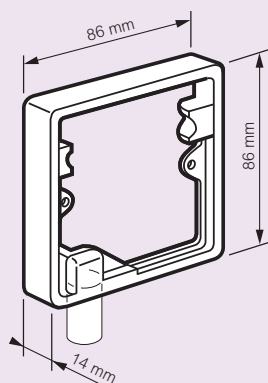

Additionally the use of cord outlet accessory box Cat. No. 7300 53, enables a flush-to-wall cable outlet option. The outlet box dimensions are nominally 86 x 86 mm and 14 mm deep. The outlet box is supplied with the necessary longer installation screws and has an integral automatic cable restraint.

**Synergy® white**  
standard engraving

**LEGRAND SYNERGY STANDARD ENGRAVING**

Engraving	20A DP SWITCHES	13A FUSED CONNECTION UNITS	
	Without cable outlet	Switched without cable outlet	Switched without cable outlet with indicator
CENTRAL HEATING	7300 10CG	7300 34CG	7300 35CG
COOKER HOOD	7300 10CH	7300 34CH	7300 35CH
DISHWASHER	7300 10DW	7300 34DW	7300 35DW
EXTRACTOR	7300 10EX	7300 34EX	7300 35EX
EXTRACTOR HOOD	7300 10EH	7300 34EH	7300 35EH
FAN	7300 10FN	7300 34FN	7300 35FN
FRIDGE	7300 10FR	7300 34FR	7300 35FR
FRIDGE FREEZER	7300 10FF	7300 34FF	7300 35FF
HEATER	7300 10HR	7300 34HR	7300 35HR
HOB	7300 10HB	7300 34HB	7300 35HB
MICROWAVE	7300 10MW	7300 34MW	7300 35MW
OVEN	7300 10OV	7300 34OV	7300 35OV
TOWEL RAIL	7300 10TR	7300 34TR	7300 35TR
TUMBLE DRYER	7300 10TD	7300 34TD	7300 35TD
WASHING MACHINE	7300 10WM	7300 34WM	7300 35WM

Full box quantities only - Pack quantity 10

**Bespoke engraving available on request.**

Engraving markings differ slightly from pad printed markings appearing elsewhere in the catalogue









For lead times of above engravings, please contact us on +44 (0) 845 605 4333 or email [technical.uk@legrand.co.uk](mailto:technical.uk@legrand.co.uk)





# Synergy® modern



switches and dimmers











Front plates : clip on die cast plate with high quality satin finish; anthracite interiors; matching decorative rockers (except where indicated)  
Terminal screws captive and backed off ready for cabling  
Hidden screws



Pack	Cat. Nos.		
	 Silver	 Nickel	
			<b>Single pole plate switches 10 AX - 250 V~</b>
			Conform to BS EN 60669-1 : 2000
			Flush mounting back box : min. 16 mm deep
			Nominal plate dimensions : 1, 2 and 3 gang - 89 x 89 mm
			4 and 6 gang - 89 x 149 mm
1	7310 00	7312 00	 1 gang – 1 way
1	7310 01	7312 01	 1 gang – 2 way
1	7310 05	7312 05	 1 gang – intermediate
1	7310 02	7312 02	 2 gang – 2 way
1	7310 03	7312 03	 3 gang – 2 way
1	7310 04	7312 04	 4 gang – 2 way

Pack	Cat. Nos.		
	 Silver	 Nickel	
			<b>Single pole plate switches 20 AX - 250 V~</b>
			Conform to BS EN 60669-1 : 2000
			Flush mounting back box : min. 25 mm deep
			Nominal plate dimensions : 89 x 89 mm
1	7311 31	7313 31	 1 gang – 2 way
1	7311 32	7313 32	 2 gang – 2 way
1	7311 33	7313 33	 3 gang – 2 way

Pack	Cat. Nos.		
	 Silver	 Nickel	
			<b>Single pole push switches 10 A - 250 V~</b>
			Conform to BS EN 60669-1 : 2000
			Flush mounting back box : min. 16 mm deep
			Nominal plate dimensions : 89 x 89 mm
1	7310 07	7312 07	 1 gang – 2 way push switch

Pack	Cat. Nos.		
	 Silver	 Nickel	
			<b>Dimmer units - 230 V~</b>
			Conform to BS EN 60669-2-1 : 2000
			Not suitable for fluorescent load
			Flush mounting back box : min. 25 mm deep
			Nominal plate dimensions : 89 x 89 mm
			Dimmers for use with tungsten filament lamps, GU10 halogen lamps and low voltage systems using appropriate transformer
1	7310 46	7312 46	 1 gang – 2 way 50 Hz 40 W-250 W push on/off rotary
1	7310 47	7312 47	 2 gang – 2 way 50 Hz 40 W-250 W push on/off rotary

Pack	Cat. Nos.		
	 Silver	 Nickel	
			<b>Dimmer units - 230 V~ - electronic type</b>
			Conform to BS EN 60669-2-1 : 2000
			Not suitable for fluorescent load
			Flush mounting back box : min. 25 mm deep
			Nominal plate dimensions : 89 x 89 mm
			Dimmers for use with tungsten filament lamps, good quality wire-wound transformers for low voltage loads
1	7311 56	7313 56	 1 gang – 2 way 50-60 Hz 40 W-400 W push on/off rotary
1	7311 57	7313 57	 2 gang – 2 way 50-60 Hz 40 W-400 W push on/off rotary

Pack	Cat. Nos.		
	 Silver	 Nickel	
			<b>3 pole fan switches 10 A - 250 V~</b>
			Conform to BS EN 60669-1 : 2000
			White rocker with integrated padlockable safety block in OFF position
			Flush mounting back box : min. 25 mm deep
			Nominal plate dimensions : 89 x 89 mm
1	7310 09	7312 09	 3 pole fan switch

# Synergy® modern

socket outlets and shaver sockets



7310 60



7312 71



7310 89





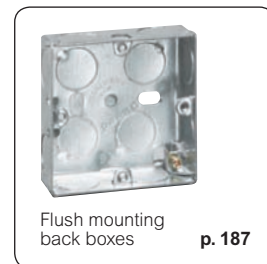



7312 59



Flush mounting back boxes





p. 187

Front plates : clip on die cast plate with high quality satin finish; anthracite interiors; matching decorative rockers (except where indicated)  
Terminal screws captive and backed off ready for cabling

Pack	Cat. Nos.		
			
	Silver	Nickel	
1	7310 60	7312 60	 1 gang – switched
1	7310 61	7312 61	 1 gang – switched + red LED power indicator
1	7310 70	7312 70	 2 gang – switched
1	7310 71	7312 71	 2 gang – switched + red LED power indicator





### Double pole socket outlets 13 A - 250 V~

Conform to BS 1363 - Part 2 : 1995  
2 earth terminals  
Flush mounting back box : min. 25 mm deep  
Nominal plate dimensions :  
1 gang - 89 x 89 mm  
2 gang - 89 x 149 mm

Pack	Cat. Nos.		
			
	Silver	Nickel	
1	7310 65	7312 65	 1 gang – unswitched
1	7310 75	7312 75	 2 gang – unswitched





### Unswitched socket outlets 13 A - 250 V~

Conform to BS 1363 - Part 2 : 1995  
2 earth terminals  
Flush mounting back box : min. 25 mm deep  
Nominal plate dimensions :  
1 gang - 89 x 89 mm  
2 gang - 89 x 149 mm

Pack	Cat. Nos.		
			
	Silver	Nickel	
1	7310 88	7312 88	 1 gang – unswitched
1	7310 89	7312 89	 1 gang – switched

### Socket outlets 15 A - 250 V~

Conform to BS 546 : 1950  
Flush mounting back box : min. 35 mm deep  
Nominal plate dimensions : 89 x 89 mm

Pack	Cat. Nos.		
			
	Silver	Nickel	
1	7310 97	7312 97	 RCD unit 2 gang DP 30 mA active
1	7310 98	7312 98	 RCD unit 2 gang DP 30 mA passive

### RCD sockets 13 A - 250 V~



Conform to BS 7288 : 1990 and BS 1363 - Part 2 : 1995  
Stainless steel plate with fixing screws  
Conventional earth pin release shutter  
Maximum operating current 16 A  
Incorporate a "test and reset" button  
Flush mounting back box : min. 25 mm deep  
Nominal plate dimensions : 86 x 146 mm

#### Active (electronically latched)

- trips in the event of a power failure
- suitable in applications where automatic restoration of supply would be hazardous, e.g. machinery, power tools





#### Passive (mechanically latched)

- does not trip in the event of a power failure
- suitable in applications where automatic restoration of supply is required, e.g. fridge, freezer, unmanned areas

Pack	Cat. Nos.		
			
	Silver	Nickel	
1	7310 59	7312 59	 1 gang – unswitched



### Socket outlets 2 A - 250 V~

Conform to BS 546 : 1950  
Flush mounting back box : min. 25 mm deep  
Nominal plate dimensions : 89 x 89 mm

Pack	Cat. Nos.		
			
	Silver	Nickel	
1	7310 68	7312 68	 1 gang – unswitched
1	7310 69	7312 69	 1 gang – switched

### Socket outlets 5 A - 250 V~

Conform to BS 546 : 1950  
Flush mounting back box : min. 25 mm deep  
Nominal plate dimensions : 89 x 89 mm

Pack	Cat. Nos.		
			
	Silver	Nickel	
1	7310 90	7312 90	 Supply : 230 V - 50/60 Hz Output : 230/120 V - 20 VA max.

### Shaver sockets

Conform to BS EN 61558-2-5 : 1998 IP 24  
For use with European, British, American and Australian 2 pin plugs  
Screwless live and neutral terminals  
Double wound isolating transformer  
Automatic self-resetting overload feature  
Plug insertion operates microswitch which energises transformer  
Flush mounting back box : min. 47 mm deep  
Nominal plate dimensions : 149 x 89 mm

# Synergy® modern

fused connection units



7310 35



7312 34



7310 30



7312 32



Flush mounting back boxes

p. 187



7310 37



7312 36



7310 31





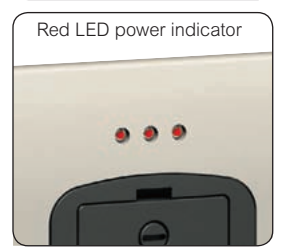









7312 33



Red LED power indicator

Front plates : clip on die cast plate with high quality satin finish; anthracite interiors; matching decorative rockers (except where indicated)  
Terminal screws captive and backed off ready for cabling

Pack	Cat. Nos.		Fused connection units 13 A - 250 V~	
			Conform to BS 1363 - Part 4 : 1995 Fuse drawer retained by quarter turn catch, drawer padlockable in open position for safety Flush mounting back box : min. 25 mm deep Nominal plate dimensions : 89 x 89 mm	
			<b>Switched</b>	
1	7310 34	7312 34		Switched, DP
1	7310 35	7312 35		Switched, DP + red LED power indicator
1	7310 36	7312 36		Switched, DP with cord outlet
1	7310 37	7312 37		Switched, DP with cord outlet + red LED power indicator

Pack	Cat. Nos.		Fused connection units 13 A - 250 V~ (continued)	
			Conform to BS 1363 - Part 4 : 1995 Fuse drawer retained by quarter turn catch, drawer padlockable in open position for safety Flush mounting back box : min. 25 mm deep Nominal plate dimensions : 89 x 89 mm	
			<b>Unswitched</b>	
1	7310 30	7312 30		Unswitched
1	7310 31	7312 31		Unswitched + red LED power indicator
1	7310 32	7312 32		Unswitched with cord outlet
1	7310 33	7312 33		Unswitched with cord outlet + red LED power indicator

# Synergy® modern control switches



7310 10



7312 12



7310 23

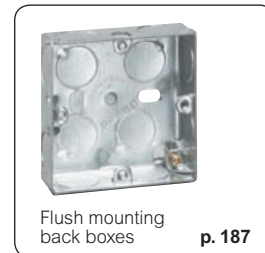

7312 22

Flush mounting  
back boxes

p. 187



7310 16



7312 14



7310 29



Red LED power indicator

Front plates : clip on die cast plate with high quality satin finish; anthracite interiors; matching decorative rockers (except where indicated)  
Terminal screws captive and backed off ready for cabling

Pack	Cat. Nos.		<b>Double pole switches 20 A - 250 V~</b>	
			Conform to BS EN 60669-1 : 2000 Flush mounting back box : min. 25 mm deep Nominal plate dimensions : 89 x 89 mm	
1	7310 10	7312 10		20 A DP
1	7310 14	7312 14		20 A DP with cord outlet
1	7310 16	7312 16		20 A DP with cord outlet + red LED power indicator
1	7310 12	7312 12		20 A DP + red LED power indicator

Pack	Cat. Nos.		<b>Cable outlets 20 A - 250 V~</b>	
			Conform to BS 5733 : 1995 Flush mounting back box : min. 25 mm deep Nominal plate dimensions : 86 x 86 mm	
1	7310 19	7312 19		20 A – with terminal block and outlet gland

Pack	Cat. Nos.		<b>Double pole switches 45 A - 250 V~</b>	
			Conform to BS EN 60669-1 : 1995 Red rocker Flush mounting back box : min. 48 mm deep Nominal plate dimensions : 89 x 89 mm	
1	7310 22	7312 22		45 A DP
1	7310 23	7312 23		45 A DP with red power indicator
			Nominal plate dimensions : 146 x 86 mm	
1	7310 21	7312 21		45 A DP with red power indicator Stainless steel plate with fixing screws

Pack	Cat. Nos.		<b>Cooker control units 45 A - 250 V~</b>	
			Conform to BS 4177 : 1992 Red rocker Flush mounting back box : min. 47 mm deep Nominal plate dimensions : 89 x 149 mm	
1	7310 29	7312 29		45 A DP switch + 13 A DP switched socket outlet

Pack	Cat. Nos.		<b>Cable outlets 45 A - 250 V~</b>	
			Conform to BS 5733 : 1995 2 piece design for safety Stainless steel plate with fixing screws Flush mounting back box : min. 48 mm deep Nominal plate dimensions : 86 x 86 mm	
1	7310 26	7312 26		45 A – with terminal block

# Synergy® modern

TV, telephone and data sockets



7310 42



7312 43

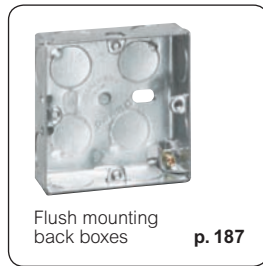

Flush mounting back boxes **p. 187**



7310 50















7312 56









8201 45

Front plates : clip on die cast plate with high quality satin finish; anthracite interiors  
Terminal screws captive and backed off ready for cabling

Pack	Cat. Nos.		TV, radio and satellite sockets
			Flush mounting back box : min. 35 mm deep Nominal plate dimensions : 89 x 89 mm
1	7310 40	7312 40	 Screened TV – single, male Non-isolated
1	7310 41	7312 41	 Screened satellite – single, 'F' type
1	7310 42	7312 42	 Screened TV + FM Isolated
1	7310 43	7312 43	 Screened TV + FM + satellite, 'F' type
			Nominal plate dimensions : 86 x 146 mm
1	7310 45 <sup>1</sup>	7312 45 <sup>1</sup>	 Quad outlet, TV, radio + 2 satellite + TV return with secondary telephone outlet <sup>2</sup>

Pack	Cat. Nos.		Telephone sockets
			Flush mounting back box : min. 35 mm deep Nominal plate dimensions : 89 x 89 mm
1	7310 50 <sup>1</sup>	7312 50 <sup>1</sup>	 Single master
1	7310 51 <sup>1</sup>	7312 51 <sup>1</sup>	 Single secondary
1	7310 54	7312 54	 Single RJ11/12

Pack	Cat. Nos.		Data sockets
			CAT 6 compliant UTP Rapid cable connection Flush mounting back box : min. 35 mm deep Nominal plate dimensions : 89 x 89 mm
1	7310 56	7312 56	 RJ45 – single
1	7310 57	7312 57	 RJ45 – double

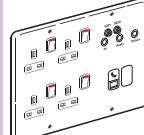
Pack	Cat. Nos.		Media plate (monobloc)
			Comprising 2 x independent satellite feeds, 1 x terrestrial TV socket suitable for analogue and digital signals, 1 x video return, 1 x secondary telephone point, 2 x Synergy 2 gang switched DP 13 A sockets To be used with back box Cat. No. 8204 58 below Dimensions : 206 x 267 mm Material : stainless steel
1	8201 46	8201 45	 Media plate

Pack	Cat. Nos.	Back box for media plate
1	8204 58	Dimensions : 194 x 254 x 35 mm With phase barrier Material : grey epoxy coated steel 35 mm deep box

1 : Not suitable for use in the ROI  
2 : Stainless steel plate with fixing screws





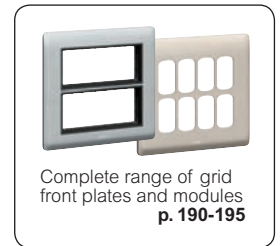
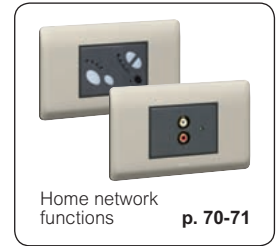

# Synergy® modern plates and yokes















Front plates : clip on die cast plate with high quality satin finish;  
anthracite interiors  
Terminal screws captive and backed off ready for cabling



Grid selection charts **p. 194-195**  
Grid modules **p. 190-192**  
Arteor modules **p. 111-131**

Pack	Cat. Nos.		Accessories
	 Silver	 Nickel	<b>Blanking plates</b>
1	7310 95	7312 95	 1 gang - 89 x 89 mm
1	7310 96	7312 96	 2 gang - 89 x 149 mm
			<b>Outlet plates - VDI/low voltage</b>
1	7310 52	7312 52	 1 gang - 89 x 89 mm with cable clamp and outlet gland

Pack	Cat. Nos.		1 and 2 gang front plates for grid modules
	 Silver	 Nickel	For yokes, see below
1	7311 91	7313 91	 1 gang - 89 x 89 mm 1 small aperture module
1	7311 92	7313 92	 1 gang - 89 x 89 mm 2 small aperture modules
1	7311 93	7313 93	 2 gang - 89 x 149 mm 3 small aperture modules
1	7311 94	7313 94	 2 gang - 89 x 149 mm 4 small aperture modules

Pack	Cat. Nos.		Carrier plates for Arteor modules (square)
	 Silver	 Nickel	No additional yoke required Enable a Synergy installation to benefit from the additional functionality of Arteor, such as international sockets etc
1	7310 91	7312 91	 1 gang - 89 x 89 mm 1 Arteor module
1	7310 92	7312 92	 1 gang - 89 x 89 mm 2 Arteor modules
1	7310 93	7312 93	 2 gang - 89 x 149 mm 3 Arteor modules
1	7310 94	7312 94	 2 gang - 89 x 149 mm 4 Arteor modules

Pack	Cat. Nos.	1 and 2 gang yokes for grid modules
10	7354 81	To suit modern front plates only  1 gang 1/2 modules
10	7354 82	 2 gang 3/4 modules

# Synergy® traditional switches and dimmers



7330 00



7332 02



7330 46



7332 47

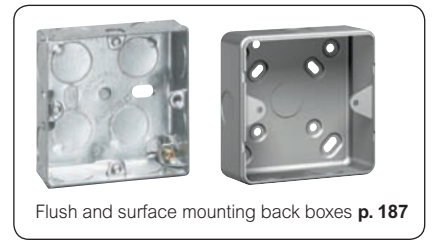

Flush and surface mounting back boxes p. 187



7330 06



7332 07



7330 09



7332 09

Brushed stainless steel front plates : brushed stainless steel with clear epoxy satin lacquer coating  
 Polished stainless steel front plates : electroplated stainless steel plate with trivalent chrome for mirror finish  
 White interiors and rockers  
 Terminal screws captive and backed off ready for cabling

Pack	Cat. Nos.		<b>Single pole plate switches 10 AX - 250 V<math>\sim</math></b>	
	Stainless steel Brushed   Polished		Conform to BS EN 60669-1 : 2000 Flush mounting back box : min. 16 mm deep Nominal plate dimensions : 1, 2 and 3 gang - 86 x 86 mm 4 and 6 gang - 86 x 146 mm	
1	7330 00	7332 00		1 gang - 1 way
1	7330 01	7332 01		1 gang - 2 way
1	7330 05	7332 05		1 gang - intermediate
1	7330 02	7332 02		2 gang - 2 way
1	7330 03	7332 03		3 gang - 2 way
1	7330 04	7332 04		4 gang - 2 way
1	7330 06	7332 06		6 gang - 2 way

Pack	Cat. Nos.		<b>Single pole plate switches 20 AX - 250 V<math>\sim</math></b>	
	Stainless steel Brushed   Polished		Conform to BS EN 60669-1 : 2000 Flush mounting back box : min. 25 mm deep Nominal plate dimensions : 86 x 86 mm	
1	7331 31	7333 31		1 gang - 2 way
1	7331 32	7333 32		2 gang - 2 way
1	7331 33	7333 33		3 gang - 2 way

Pack	Cat. Nos.		<b>Single pole push switches 10 A - 250 V<math>\sim</math></b>	
	Stainless steel Brushed   Polished		Conform to BS EN 60669-1 : 2000 Flush mounting back box : min. 16 mm deep Nominal plate dimensions : 86 x 86 mm	
1	7330 07	7332 07		1 gang - 2 way push switch

Pack	Cat. Nos.		<b>Dimmer units - 230 V<math>\sim</math></b>	
	Stainless steel Brushed   Polished		Conform to BS EN 60669-2-1 : 2000 and BS EN 55015 Not suitable for fluorescent load Flush mounting back box : min. 25 mm deep Nominal plate dimensions : 86 x 86 mm Dimmers for use with tungsten filament lamps, GU10 halogen lamps and low voltage systems using appropriate transformer	
1	7330 46	7332 46		1 gang - 2 way 50 Hz 40 W-250 W push on/off rotary
1	7330 47	7332 47		2 gang - 2 way 50 Hz 40 W-250 W push on/off rotary

Pack	Cat. Nos.		<b>Dimmer units - 230 V<math>\sim</math> - electronic type</b>	
	Stainless steel Brushed   Polished		Conform to BS EN 60669-2-1 : 2000 and BS EN 55015 Not suitable for fluorescent load Flush mounting back box : min. 25 mm deep Nominal plate dimensions : 86 x 86 mm Dimmers for use with tungsten filament lamps, good quality wire-wound transformers for low voltage loads	
1	7331 56	7333 56		1 gang - 2 way 50-60 Hz 40 W-400 W push on/off rotary
1	7331 57	7333 57		2 gang - 2 way 50-60 Hz 40 W-400 W push on/off rotary

Pack	Cat. Nos.		<b>3 pole fan switches 10 A - 250 V<math>\sim</math></b>	
	Stainless steel Brushed   Polished		Conform to BS EN 60669-1 : 2000 With integrated padlockable safety block in OFF position Flush mounting back box : min. 25 mm deep Nominal plate dimensions : 86 x 86 mm	
1	7330 09	7332 09		3 pole fan switch

# Synergy® traditional socket outlets



7330 70



7332 61



7330 97

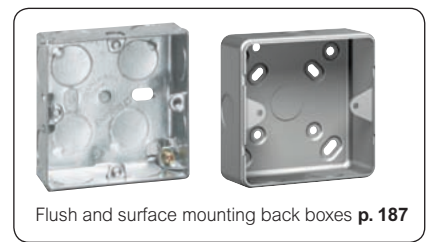

Flush and surface mounting back boxes p. 187



7330 71



7332 74



7330 89



7332 59



Red LED power indicator

Brushed stainless steel front plates : brushed stainless steel with clear epoxy satin lacquer coating  
 Polished stainless steel front plates : electroplated stainless steel plate with trivalent chrome for mirror finish  
 White interiors and rockers  
 Terminal screws captive and backed off ready for cabling

Pack	Cat. Nos.								
			<b>Double pole socket outlets 13 A - 250 V~</b>						
			Conform to BS 1363 - Part 2 : 1995 2 earth terminals Flush mounting back box : min. 25 mm deep Nominal plate dimensions : 1 gang - 86 x 86 mm 2 gang - 86 x 146 mm						
			<table border="0"> <tr> <td colspan="2">Stainless steel</td> </tr> <tr> <td></td> <td></td> </tr> <tr> <td>Brushed</td> <td>Polished</td> </tr> </table>	Stainless steel				Brushed	Polished
Stainless steel									
Brushed	Polished								
1	7330 60	7332 60	1 gang – switched						
1	7330 61	7332 61	1 gang – switched + red LED power indicator						
1	7330 70	7332 70	2 gang – switched						
1	7330 71	7332 71	2 gang – switched + red LED power indicator						
1	7330 74	7332 74	2 gang – switched outboard for standard and clean earth applications						

Pack	Cat. Nos.								
			<b>Unswitched socket outlets 13 A - 250 V~</b>						
			Conform to BS 1363 - Part 2 : 1995 2 earth terminals Flush mounting back box : min. 25 mm deep Nominal plate dimensions : 1 gang - 86 x 86 mm 2 gang - 86 x 146 mm						
			<table border="0"> <tr> <td colspan="2">Stainless steel</td> </tr> <tr> <td></td> <td></td> </tr> <tr> <td>Brushed</td> <td>Polished</td> </tr> </table>	Stainless steel				Brushed	Polished
Stainless steel									
Brushed	Polished								
1	7330 65	7332 65	1 gang – unswitched						
1	7330 75	7332 75	2 gang – unswitched						

Pack	Cat. Nos.								
			<b>Key switched socket 13 A - 250 V~</b>						
			Conform to BS 1363 - part 2 : 1995 Flush mounting back box : min. 35 mm deep Nominal plate dimensions : 86 x 146 mm						
			<table border="0"> <tr> <td colspan="2">Stainless steel</td> </tr> <tr> <td></td> <td></td> </tr> <tr> <td>Brushed</td> <td>Polished</td> </tr> </table>	Stainless steel				Brushed	Polished
Stainless steel									
Brushed	Polished								
1	8200 71	8200 72	2 gang single socket with DP key switch						
			<b>RCD sockets 13 A - 250 V~</b>						
			Conform to BS 7288 : 1990 and BS 1363 - Part 2 : 1995 Conventional earth pin release shutter Maximum operating current 16 A Incorporate a "test and reset" button Flush mounting back box : min. 25 mm deep Nominal plate dimensions : 86 x 146 mm						
			<b>Active (electronically latched)</b> - trips in the event of a power failure - suitable in applications where automatic restoration of supply would be hazardous, e.g. machinery, power tools						
			<table border="0"> <tr> <td colspan="2">Stainless steel</td> </tr> <tr> <td></td> <td></td> </tr> <tr> <td>Brushed</td> <td>Polished</td> </tr> </table>	Stainless steel				Brushed	Polished
Stainless steel									
Brushed	Polished								
1	7330 97	7332 97	RCD unit 2 gang DP 30 mA active						
			<b>Passive (mechanically latched)</b> - does not trip in the event of a power failure - suitable in applications where automatic restoration of supply is required, e.g. fridge, freezer, unmanned areas						
			<table border="0"> <tr> <td colspan="2">Stainless steel</td> </tr> <tr> <td></td> <td></td> </tr> <tr> <td>Brushed</td> <td>Polished</td> </tr> </table>	Stainless steel				Brushed	Polished
Stainless steel									
Brushed	Polished								
1	7330 98	7332 98	RCD unit 2 gang DP 30 mA passive						

Pack	Cat. Nos.								
			<b>Socket outlets 15 A - 250 V~</b>						
			Conform to BS 546 : 1950 Flush mounting back box : min. 35 mm deep Nominal plate dimensions : 86 x 86 mm						
			<table border="0"> <tr> <td colspan="2">Stainless steel</td> </tr> <tr> <td></td> <td></td> </tr> <tr> <td>Brushed</td> <td>Polished</td> </tr> </table>	Stainless steel				Brushed	Polished
Stainless steel									
Brushed	Polished								
1	7330 88	7332 88	1 gang – unswitched						
1	7330 89	7332 89	1 gang – switched						

Pack	Cat. Nos.								
			<b>Socket outlets 2 A - 250 V~</b>						
			Conform to BS 546 : 1950 Flush mounting back box : min. 25 mm deep Nominal plate dimensions : 86 x 86 mm						
			<table border="0"> <tr> <td colspan="2">Stainless steel</td> </tr> <tr> <td></td> <td></td> </tr> <tr> <td>Brushed</td> <td>Polished</td> </tr> </table>	Stainless steel				Brushed	Polished
Stainless steel									
Brushed	Polished								
1	7330 59	7332 59	1 gang – unswitched						

# Synergy® traditional

socket outlets (continued) and fused connection units



7330 68



7330 35



7332 30

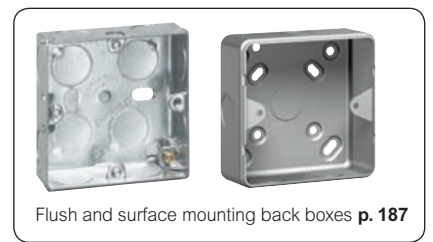

7330 69



7330 90



7330 37



7332 32



Brushed stainless steel front plates : brushed stainless steel with clear epoxy satin lacquer coating  
 Polished stainless steel front plates : electroplated stainless steel plate with trivalent chrome for mirror finish  
 White interiors and rockers  
 Terminal screws captive and backed off ready for cabling

Pack	Cat. Nos.		Socket outlets 5 A - 250 V~
	Stainless steel Brushed      Polished		Conform to BS 546 : 1950 Flush mounting back box : min. 25 mm deep Nominal plate dimensions : 86 x 86 mm
1	7330 68	7332 68	1 gang – unswitched
1	7330 69	7332 69	1 gang – switched

Pack	Cat. Nos.		Shaver sockets
	Stainless steel Brushed      Polished		Conform to BS EN 61558-2-5 : 1998 IP 24 For use with European, British, American and Australian 2 pin plugs Screwless live and neutral terminals Double wound isolating transformer Automatic self-resetting overload feature Plug insertion operates microswitch which energises transformer Flush mounting back box : min. 47 mm deep Nominal plate dimensions : 146 x 86 mm
1	7330 90	7332 90	Supply : 230 V - 50/60 Hz Output : 230/120 V - 20 VA max.

Pack	Cat. Nos.		Fused connection units 13 A - 250 V~
	Stainless steel Brushed      Polished		Conform to BS 1363 - Part 4 : 1995 Fuse drawer retained by quarter turn catch, drawer padlockable in open position for safety Flush mounting back box : min. 25 mm deep Nominal plate dimensions : 86 x 86 mm
			<b>Switched</b>
1	7330 34	7332 34	Switched, DP
1	7330 35	7332 35	Switched, DP with red LED power indicator
1	7330 36	7332 36	Switched, DP with cord outlet
1	7330 37	7332 37	Switched, DP with cord outlet + red LED power indicator
			<b>Unswitched</b>
1	7330 30	7332 30	Unswitched
1	7330 31	7332 31	Unswitched with red LED power indicator
1	7330 32	7332 32	Unswitched with cord outlet
1	7330 33	7332 33	Unswitched with cord outlet + red LED power indicator

# Synergy® traditional control switches



7330 14



7332 10



7330 22

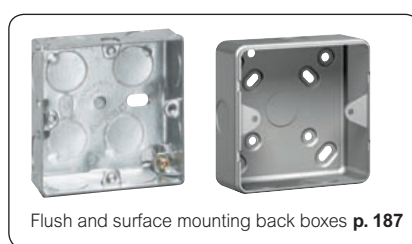

7332 22

Flush and surface mounting back boxes **p. 187**

7330 12



7332 16



7330 23



7332 29



Red LED power indicator

Brushed stainless steel front plates : brushed stainless steel with clear epoxy satin lacquer coating  
 Polished stainless steel front plates : electroplated stainless steel plate with trivalent chrome for mirror finish  
 White interiors and rockers (red rockers for specific items)  
 Terminal screws captive and backed off ready for cabling

Pack	Cat. Nos.		Double pole switches 20 A - 250 V $\sim$	
	Stainless steel		Conform to BS EN 60669-1 : 2000	
	Brushed	Polished	Flush mounting back box : min. 25 mm deep	
			Nominal plate dimensions : 86 x 86 mm	
1	7330 10	7332 10		20 A DP
1	7330 14	7332 14		20 A DP with cord outlet
1	7330 16	7332 16		20 A DP with cord outlet + red LED power indicator
1	7330 12	7332 12		20 A DP with red LED power indicator

Pack	Cat. Nos.		Cable outlets 20 A - 250 V $\sim$	
	Stainless steel		Conform to BS 5733 : 1995	
	Brushed	Polished	Flush mounting back box : min. 25 mm deep	
			Nominal plate dimensions : 86 x 86 mm	
1	7330 19	7332 19		20 A - with terminal block and outlet gland

Pack	Cat. Nos.		Double pole switches 45 A - 250 V $\sim$	
	Stainless steel		Conform to BS EN 60669-1 : 2000	
	Brushed	Polished	Red rocker	
			Flush mounting back box : min. 48 mm deep	
			Nominal plate dimensions :	
			2 gang - 146 x 86 mm	
			1 gang - 86 x 86 mm	
1	7330 20	7332 20		45 A DP
1	7330 21	7332 21		45 A DP with red LED power indicator
1	7330 22	7332 22		45 A DP
1	7330 23	7332 23		45 A DP with red LED power indicator

Pack	Cat. Nos.		Cooker control units 45 A - 250 V $\sim$	
	Stainless steel		Conform to BS 4177 : 1992	
	Brushed	Polished	45 A - 250 V $\sim$ DP switch with 13 A - 250 V $\sim$ DP switched socket outlet	
			Red rocker	
			Flush mounting back box : min. 48 mm deep	
			Nominal plate dimensions : 86 x 146 mm	
1	7330 28	7332 28		DP with DP switched socket
1	7330 29	7332 29		DP with DP switched socket + red LED power indicators

Pack	Cat. Nos.		Cable outlets 45 A - 250 V $\sim$	
	Stainless steel		Conform to BS 5733 : 1995	
	Brushed	Polished	2 piece design for safety	
			Flush mounting back box : min. 48 mm deep	
			Nominal plate dimensions : 86 x 86 mm	
1	7330 26	7332 26		45 A - with terminal block

# Synergy® traditional

TV, telephone and data sockets



7330 43



7332 42

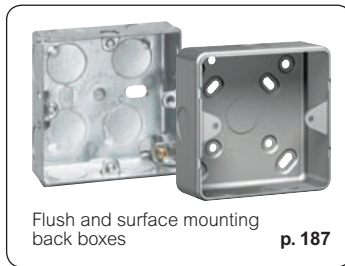

Flush and surface mounting  
back boxes **p. 187**



7330 50



7332 57



8201 43

Brushed stainless steel front plates : brushed stainless steel with clear epoxy satin lacquer coating  
 Polished stainless steel front plates : electroplated stainless steel plate with trivalent chrome for mirror finish  
 White interiors and rockers  
 Terminal screws captive and backed off ready for cabling

Pack	Cat. Nos.		TV, radio and satellite sockets
	Stainless steel		Flush mounting back box : min. 35 mm deep Nominal plate dimensions : 86 x 86 mm
	Brushed	Polished	
1	7330 40	7332 40	Screened TV – single, male Non-isolated
1	7330 41	7332 41	Screened satellite – single, 'F' type
1	7330 42	7332 42	Screened TV + FM Isolated
1	7330 43	7332 43	Screened TV + FM + satellite, 'F' type
1	7330 45 <sup>1</sup>	7332 45 <sup>1</sup>	Quad outlet, TV, radio + 2 satellite + TV return with secondary telephone outlet <sup>2</sup>

Pack	Cat. Nos.		Telephone sockets
	Stainless steel		Flush mounting back box : min. 35 mm deep Nominal plate dimensions : 86 x 86 mm
	Brushed	Polished	
1	7330 50 <sup>1</sup>	7332 50 <sup>1</sup>	Single master
1	7330 51 <sup>1</sup>	7332 51 <sup>1</sup>	Single secondary
1	7330 54	7332 54	Single RJ11/12

Pack	Cat. Nos.		Data sockets
	Stainless steel		CAT 6 compliant UTP Rapid cable connection
	Brushed	Polished	Flush mounting back box : min. 35 mm deep Nominal plate dimensions : 86 x 86 mm
1	7330 56	7332 56	RJ45 – single
1	7330 57	7332 57	RJ45 – double

Pack	Cat. Nos.		Media plates (monobloc)
	Stainless steel		Comprising 2 x independent satellite feeds, 1 x terrestrial TV socket suitable for analogue and digital signals, 1 x video return, 1 x secondary telephone point, 2 x Synergy 2 gang switched DP 13 A sockets To be used with back box Cat. No. 8204 58 below Dimensions : 206 x 267 mm Material : stainless steel
	Brushed	Polished	
1	8201 43	8201 44	Media plate

Pack	Cat. Nos.	Back box for media plate
1	8204 58	Dimensions : 194 x 254 x 35 mm With phase barrier Material : grey epoxy coated steel 35 mm deep box

1 : Not suitable for use in the ROI  
 2 : Stainless steel plate with fixing screws

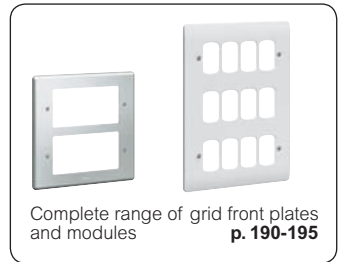

# Synergy® traditional plates and yokes











Brushed stainless steel front plates : brushed stainless steel with clear epoxy satin lacquer coating  
 Polished stainless steel front plates : electroplated stainless steel plate with trivalent chrome for mirror finish  
 Terminal screws captive and backed off ready for cabling





Grid selection charts **p. 194-195**  
 Grid modules **p. 190-192**  
 Arteor modules **p. 111-131**

Pack	Cat. Nos.		Accessories
	Stainless steel		<b>Blanking plates</b>
	Brushed	Polished	
1	7330 95	7332 95	 1 gang - 86 x 86 mm
1	7330 96	7332 96	 2 gang - 86 x 146 mm
	Stainless steel		<b>Outlet plates - VDI/low voltage</b>
	Brushed	Polished	
1	7330 52	7332 52	 1 gang - 86 x 86 mm with cable clamp and outlet gland

Pack	Cat. Nos.		1 and 2 gang front plates for grid modules
	Stainless steel		For yokes, see below
	Brushed	Polished	
1	7331 91	7333 91	 1 gang - 86 x 86 mm 1 small aperture module
1	7331 92	7333 92	 1 gang - 89 x 89 mm 2 small aperture modules
1	7331 93	7333 93	 2 gang - 86 x 146 mm 3 small aperture modules
1	7331 94	7333 94	 2 gang - 86 x 146 mm 4 small aperture modules

Pack	Cat. Nos.		Carrier plates for Arteor modules (square)
	Stainless steel		No additional yoke required Enable a Synergy installation to benefit from the additional functionality of Arteor, such as international sockets etc
	Brushed	Polished	
1	7330 91	7332 91	 1 gang - 86 x 86 mm 1 Arteor module
1	7330 92	7332 92	 1 gang - 86 x 86 mm 2 Arteor modules
1	7330 93	7332 93	 2 gang - 86 x 146 mm 3 Arteor modules
1	7330 94	7332 94	 2 gang - 86 x 146 mm 4 Arteor modules

Pack	Cat. Nos.	1 and 2 gang yokes for grid modules
10	7354 90	 1 gang 1 module
10	7354 91	 1 gang 2 modules
10	7354 92	 2 gang 3/4 modules

# MEIGaN



## socket outlets

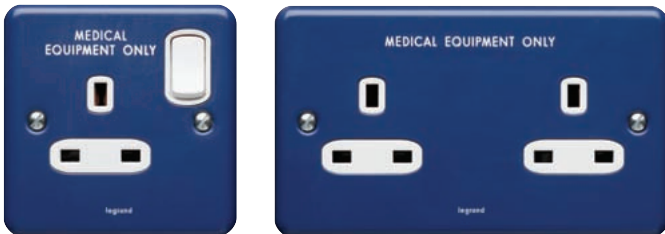

Healthcare organisations have clear guidelines regarding electrical installations within their establishments.

To meet these exacting requirements, Legrand offers a selection of corresponding blue socket outlets with white engraved lettering indicating **MEDICAL EQUIPMENT ONLY**.

Manufactured from high quality stainless steel for strength and durability, the following configurations are available :

- 1 gang - switched or unswitched (clean earth)
- 2 gang - switched or unswitched (clean earth)

### Synergy® MEIGaN socket outlets



8204 50

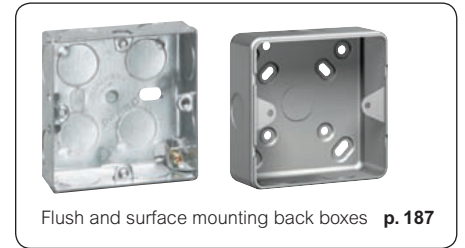

Flush and surface mounting back boxes **p. 187**



8204 53

For use in healthcare establishments  
Engraved in white lettering 'MEDICAL EQUIPMENT ONLY'  
Blue coated stainless steel front plates  
White interiors and rockers  
Terminal screws captive and backed off ready for cabling

Pack	Cat. Nos.	Double pole switched socket outlets 13 A - 250 V~
1	8204 50	<p>Conform to BS 1363 - Part 2 : 1995 Patented 3 pin safety shutter mechanism 2 earth terminals Flush mounting back box : min. 25 mm deep Nominal plate dimensions : 1 gang : 86 x 86 mm 2 gang : 86 x 146 mm</p> <p>1 gang – switched for clean earth applications</p>
1	8204 51	<p>2 gang – switched outboard for clean earth applications</p>
1	8204 52	<p>Conform to BS 1363 - Part 2 : 1995 Patented 3 pin safety shutter mechanism 2 earth terminals Flush mounting back box : min. 25 mm deep Nominal plate dimensions : 1 gang : 86 x 86 mm 2 gang : 86 x 146 mm</p> <p>1 gang – unswitched for clean earth applications</p>
1	8204 53	<p>2 gang – unswitched for clean earth applications</p>

**Matching blue accessories available on request via our bespoke products service  
Contact us on +44 (0) 845 605 4333**



# Synergy® metalclad

switches and socket outlets



Finish : grey epoxy coated steel  
Terminal screws captive and backed off ready for cabling  
Supplied complete with close fit surface mounting back box with knockouts

Pack	Cat. Nos.	Single pole plate switches 10 AX - 250 V~
		Conform to BS EN 60669-1 : 2000 Nominal dimensions : 86 x 86 x 43 mm
5	7338 00	1 gang – 1 way 1 gang – 2 way 1 gang – intermediate
5	7338 01	
5	7338 05	
5	7338 02	2 gang – 2 way
5	7338 03	3 gang – 2 way

Pack	Cat. Nos.	Double pole socket outlets 13 A - 250 V~
		Conform to BS 1363 - Part 2 : 1995 2 earth terminals Nominal dimensions : 86 x 86 x 43 mm
5	7338 60	1 gang – switched
5	7338 61	1 gang – switched + red LED power indicator Nominal dimensions : 86 x 146 x 43 mm
5	7338 70	2 gang – switched
5	7338 71	2 gang – switched + red LED power indicator

Pack	Cat. Nos.	Unswitched and key switched socket outlets 13 A - 250 V~
		Conform to BS 1363 - Part 2 : 1995 2 earth terminals Nominal plate dimensions : 1 gang - 86 x 86 mm 2 gang - 86 x 146 mm
10	7338 65	1 gang – unswitched
5	7338 75	2 gang – unswitched
1	8200 73	2 gang single socket with DP key switch

Pack	Cat. Nos.	RCD sockets 13 A - 250 V~
		Conform to BS 7288 : 1990 and BS 1363 - Part 2 : 1995 Conventional earth pin release shutter Maximum operating current 16 A Incorporate a "test and reset" button Nominal dimensions : 86 x 146 x 43 mm
		<b>Active (electronically latched)</b> - trips in the event of a power failure - suitable in applications where automatic restoration of supply would be hazardous, e.g. machinery, power tools
1	7338 97	RCD unit 2 gang DP 30 mA active
		<b>Passive (mechanically latched)</b> - does not trip in the event of a power failure - suitable in applications where automatic restoration of supply is required, e.g. fridge, freezer, unmanned areas
1	7338 98	RCD unit 2 gang DP 30 mA passive

Pack	Cat. Nos.	Socket outlets 15 A - 250 V~
		Conform to BS 546 : 1950 Nominal dimensions : 86 x 86 x 43 mm
5	7338 88	1 gang – unswitched
5	7338 89	1 gang – switched

# Synergy® metalclad

fused connection units and control switches



7338 34



7338 37



7338 12



7338 31



7338 32



7338 19



7338 21



Finish : grey epoxy coated steel  
Terminal screws captive and backed off ready for cabling  
Supplied complete with close fit surface mounting back box with knockouts

Pack	Cat. Nos.	Fused connection units 13 A - 250 V~
		Conform to BS 1363 - Part 4 : 1995 Fused 13 A (fuse supplied) Fuse drawer retained by quarter turn catch, drawer padlockable in open position for safety Nominal dimensions : 86 x 86 x 43 mm
		<b>Switched</b>
5	7338 34	Switched, DP
5	7338 35	Switched, DP with red LED power indicator
5	7338 36	Switched, DP with cord outlet
5	7338 37	Switched, DP with cord outlet + red LED power indicator
		<b>Unswitched</b>
5	7338 30	Unswitched
5	7338 31	Unswitched with red LED power indicator
5	7338 32	Unswitched with cord outlet
5	7338 33	Unswitched with cord outlet + red LED power indicator

Pack	Cat. Nos.	Double pole switches 20 A - 250 V~
		Conform to BS EN 60669-1 : 2000 Nominal dimensions : 86 x 86 x 43 mm
5	7338 10	20 A DP
5	7338 14	20 A DP with cord outlet
5	7338 16	20 A DP with cord outlet + red LED power indicator
5	7338 12	20 A DP + red LED power indicator
		<b>Cable outlet 20 A - 250 V~</b>
		Conforms to BS 5733 : 1995 Nominal dimensions : 86 x 86 x 43 mm
5	7338 19	20 A - with terminal block and outlet gland
		<b>Double pole switches 45 A - 250 V~</b>
		Conform to BS EN 60669-1 : 2000 Red rocker Nominal dimensions : 146 x 86 x 43 mm
5	7338 20	45 A DP
5	7338 21	45 A DP + red LED power indicator

# Synergy® metalclad

TV, telephone and data sockets



7338 40



7338 41



7338 56



7338 57



7338 50



7338 95



7338 96

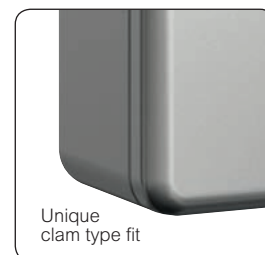

Finish : grey epoxy coated steel  
Terminal screws captive and backed off ready for cabling  
Supplied complete with close fit surface mounting back box with knockouts

Pack	Cat. Nos.	TV, radio and satellite sockets
5	7338 40	Nominal dimensions : 86 x 86 x 43 mm Screened TV – single, male Non-isolated
1	7338 41	Screened satellite – single, 'F' type

Pack	Cat. Nos.	Telephone sockets
5	7338 50 <sup>1</sup>	Nominal dimensions : 86 x 86 x 43 mm Single master
5	7338 51 <sup>1</sup>	Single secondary

Pack	Cat. Nos.	Data sockets
1	7338 56	CAT 6 compliant Rapid cable connection Nominal dimensions : 86 x 86 x 43 mm RJ45 – single
1	7338 57	RJ45 – double

Pack	Cat. Nos.	Blanking plates
5	7338 95	1 gang - 86 x 86 mm
5	7338 96	2 gang - 86 x 146 mm

1 : Not suitable for use in the ROI

# Synergy® metalclad plates and yokes



7338 92



Arteor modules p. 111-131

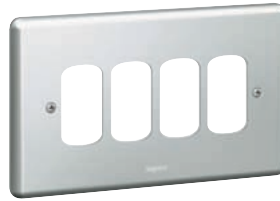

7339 94

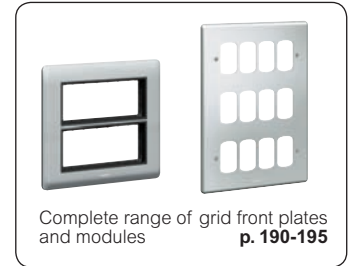

Complete range of grid front plates and modules p. 190-195



7338 92 + international socket Cat. No. 5721 18





7354 90







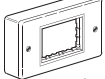
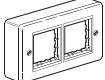

7354 92



Grid selection charts p. 194-195  
Grid modules p. 190-192  
Arteor modules p. 111-131

Pack	Cat. Nos.	Carrier plates for Arteor modules (square)
		No additional yoke required Enable a Synergy installation to benefit from the additional functionality of Arteor, such as international sockets etc
5	7338 91	 1 gang - 86 x 86 mm 1 Arteor module
5	7338 92	 1 gang - 86 x 86 mm 2 Arteor modules
5	7338 93	 2 gang - 86 x 146 mm 3 Arteor modules
5	7338 94	 2 gang - 86 x 146 mm 4 Arteor modules

Pack	Cat. Nos.	1 and 2 gang plates for grid modules
		For yokes, see below
1	7339 91	 1 gang - 86 x 86 mm 1 small aperture module
1	7339 92	 1 gang - 86 x 86 mm 2 small aperture modules
1	7339 93	 2 gang - 86 x 146 mm 3 small aperture modules
1	7339 94	 2 gang - 86 x 146 mm 4 small aperture modules

Pack	Cat. Nos.	1 and 2 gang yokes for grid modules
10	7354 90	 1 gang 1 module
10	7354 91	 1 gang 2 modules
10	7354 92	 2 gang 3/4 modules

## flush mounting steel back boxes



0891 10



0891 13



0891 11





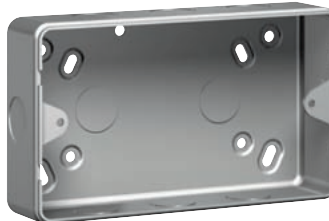

## surface mounting metal back boxes





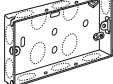

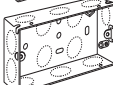
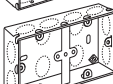

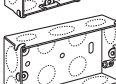



7364 00



7364 01

Pack	Cat. Nos.	Flush mounting back boxes
		Conform to BS 4662 Material : galvanised steel Top, side and back knockout entries according to type of box
100	0891 09	<b>Depth 16 mm</b>  1 gang with 1 fixed lug, 1 adjustable lug and 1 earth terminal
50	0891 10	<b>Depth 25 mm</b>  1 gang with 3 fixed lugs, 1 adjustable lug and 1 earth terminal
10	0891 11	 2 gang with 1 fixed lug, 1 adjustable lug and 1 earth terminal
50	0891 13	<b>Depth 35 mm</b>  1 gang with 3 fixed lugs, 1 adjustable lug and 1 earth terminal
40	0891 14	 2 gang with 1 fixed lug, 1 adjustable lug and 1 earth terminal
40	0891 40	 Dual box with 2 earth terminals Accepts 2 single gang accessories
25	0891 17	<b>Depth 48 mm</b>  1 gang with 3 fixed lugs, 1 adjustable lug and 1 earth terminal
20	0891 18	 2 gang with 1 fixed lug, 1 adjustable lug and 1 earth terminal

Pack	Cat. Nos.	Architrave back boxes
5	7364 40	<b>Depth 26 mm</b>  Dimensions : 82 x 28 mm
5	7364 41	 Dimensions : 142 x 28 mm

Pack	Cat. Nos.	Surface mounting metal back boxes
		Only suitable for use with Synergy traditional and metalclad finishes and Synergy grid Conform to BS 5733 where applicable Material : grey epoxy coated steel
		<b>Depth 37 mm</b>
10	7364 00	Dimensions : 86 x 86 mm  1 gang With knockouts
10	7364 20	 1 gang Without knockouts
5	7364 01	Dimensions : 86 x 146 mm  2 gang With knockouts
5	7364 21	 2 gang Without knockouts
1	7364 18	Dimensions : 146 x 146 mm  6/8 module grid With knockouts
1	7364 22	 6/8 module grid Without knockouts
1	7364 28	Dimensions : 207 x 146 mm  9/12 module grid With knockouts
1	7364 32	 9/12 module grid Without knockouts

# extend your options



From hotels, offices, restaurants, shops and warehouses to residential applications, Synergy Grid extends the appeal of the Synergy range even further... giving you the flexibility you need to create multi-function, 1 to 24 gang plates which seamlessly integrate with the style and needs of your installation.

## The functions you need, the finish you want in a single modular solution

A vast selection of function modules, available in white and anthracite, and a complete range of finishes make Synergy Grid the flexible solution for any residential or commercial application.

In addition to a complete selection of switch modules, including key and push switches, the Synergy Grid range also incorporates communication modules for TV, audio and networking functions, plus an enhanced range of electronic dimmers and time delay switches.



### Synergy Grid... unrivalled versatility without compromise

The 'mix and match' versatility of Synergy Grid provides almost limitless options. For example:

- a white surround plate with anthracite modules creates an instant solution to the visual contrast requirements of Part M of the Building Regulations
- venture beyond the capabilities of the standard wiring accessory using a combination of specialist functions within one plate
- choose standard or bespoke engravings to match any specification via our bespoke service

For bespoke solutions, contact us on +44 (0) 845 605 4333

# Synergy® grid system

## switch modules



7354 00



7355 01



7354 11



7355 17



7354 21



Decorative rockers p. 192



Installation options **p. 193**  
Grid selection charts **p. 194-195**

Modules mount from front into grid yokes  
Individually removable without disturbing grid

Pack	Cat. Nos.		Single pole switch modules 10 AX - 250 V $\sim$
			Conform to BS EN 60669-1
10	White 7354 00	Anthracite 7355 00	1 way switch
10	7354 01	7355 01	1 way switch + red LED power indicator
10	7354 03	7355 03	2 way switch
10	7354 07	7355 07	Intermediate switch

Pack	Cat. Nos.		Single pole switch modules 20 AX - 250 V $\sim$	
			Conform to BS EN 60669-1	
10	White 7354 10	Anthracite 7355 10	1 way switch	
1	7354 11	7355 11	1 way switch + red LED power indicator	
10	7354 12	7355 12	2 way switch	
10	7354 13	7355 13		2 way centre off <sup>1</sup>
10	7354 14	7355 14		2 way retractive centre off <sup>1</sup>
1	7354 14AR	7355 14AR	2 way retractive centre off marked with up + down arrows <sup>1</sup>	
10	7354 15	7355 15	2 way push switch <sup>1</sup>	
10	7354 18	7355 18	Intermediate switch	

Pack	Cat. Nos.		Single pole push switch modules 10 A - 250 V $\sim$
			Conform to BS EN 60669-1
10	White 7354 05	Anthracite 7355 05	2 way push switch
1	7354 05PE	7355 05PE	2 way push switch marked "PRESS TO EXIT"
1	7354 06	7355 06	2 way push switch marked "BELL"

Pack	Cat. Nos.		Single pole key switch modules 20 AX - 250 V $\sim$	
			Conform to BS EN 60669-1 Key supplied	
10	White 7354 16	Anthracite 7355 16	2 way key switch	
10	7354 17	7355 17		2 way key switch retractive centre off <sup>1</sup>
1	7354 19	7355 19		Intermediate switch

1 : 20 A rated only

Pack	Cat. Nos.		Double pole switch modules 20 AX - 250 V $\sim$
			Conform to BS EN 60669-1
10	White 7354 20	Anthracite 7355 20	Switch
10	7354 21	7355 21	Switch + red LED power indicator
10	7354 22	7355 22	Push to make <sup>1</sup>
1	7354 25	7355 25	
			Double pole key switch modules 20 AX - 250 V $\sim$
	White	Anthracite	Conform to BS EN 60669-1 Key supplied
10	7354 23	7355 23	Key switch
10	7354 23ET	7355 23ET	
10	7354 24	7355 24	Key switch + red LED power indicator
5	0811 77		Spare key for Synergy key switch functions

1 : 20 A rated only



# Synergy® grid system

dimmer, fuse carrier and ancillary modules



7355 48



7350 30



7351 62



7352 56



7355 41



7352 65



7355 35



Installation options **p. 193**  
Grid selection charts **p. 194-195**

Modules mount from front into grid yokes  
Individually removable without disturbing grid

Pack	Cat. Nos.	Dimmer unit modules 100-240 V~ 50/60 Hz	Pack	Cat. Nos.	Ancillary modules
1	White 7354 46	Dimmer for use with tungsten filament lamps, good quality wire-wound transformers and compatible electronic transformers for low voltage loads <sup>1</sup> 40 - 300 W Not suitable for fluorescent loads	1	White 7354 50	Telephone socket - single master Telephone socket - single secondary
	Anthracite 7355 46			Anthracite 7355 50	
1	White 7354 48	<b>Dimmer unit modules - dimmable HF ballast fluorescent</b> 100-240 V~ 50/60 Hz Conform to BS EN 60669-2-1 1 way leading edge dimmer for dimmable HF ballast fluorescent 0-10 V 400 W	10	7352 56	RJ 45 data outlet CAT 6 compliant Rapid cable connection UTP 8 contact
	Anthracite 7355 48			7353 56	
1	White 7354 47	<b>Time delay switch</b> 100-240 V~ 50/60 Hz Conform to BS EN 60669-2-3 Multiple way soft start time delay switch Push operated delay pre-set for 3, 10 or 30 minutes 40 - 400 W Not suitable for fluorescent loads	10	7354 40	Screened TV - single Non-isolated male Ø9-5 mm
	Anthracite 7355 47			7355 40	
10	White 7350 30	<b>Fuse carrier modules</b> 13 A - 250 V~ Conform to BS 5733 Fuse module fitted with BS 1362 13 A fuse	10	7354 41	Screened satellite
	Anthracite 7351 30			7355 41	
1	White 7350 60	<b>Indicator modules - 250 V~</b> Conform to BS 5733 Indicator - red LEDs Indicator - green LEDs	1	7352 65	Hi-fi outlet - screw terminal
	Anthracite 7351 60			7353 65	
1	White 7350 62		20	7354 35	Cable outlet
	Anthracite 7351 62			7355 35	
				7354 36	Blank module

<sup>1</sup> : Can be used in conjunction with compatible electronic transformers for low voltage loads. It will be necessary to test that the dimmer mechanism is compatible with the electronic transformer identified for installation

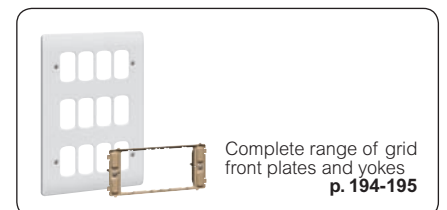



# Synergy® grid system





decorative rockers and rocker markings

## SYNERGY GRID MODULES WITH DECORATIVE ROCKERS

Complete range of Synergy Modern p. 170-175

DECORATIVE ROCKERS		MODERN SILVER	MODERN NICKEL
			
FUNCTIONS	Pack		
10 AX switch 1 x 1 way	1	7355 00MS	7355 00MN
10 AX switch 1 x 2 way	1	7355 03MS	7355 03MN
10 AX switch 1 x intermediate	1	7355 07MS	7355 07MN
10 A push switch 1 x 2 way	1	7355 05MS	7355 05MN
20 AX SP switch 1 way	1	7355 10MS	7355 10MN
20 AX SP switch 2 way	1	7355 12MS	7355 12MN
20 AX SP switch 2 way centre off	1	7355 13MS	7355 13MN
20 AX SP switch 2 way retractive centre off	1	7355 14MS	7355 14MN
20 AX SP push switch 2 way	1	7355 15MS	7355 15MN
20 AX SP intermediate switch	1	7355 18MS	7355 18MN
20 AX DP switch	1	7355 20MS	7355 20MN
20 AX DP push to make switch	1	7355 22MS	7355 22MN

## SYNERGY GRID MODULES ENGRAVED WITH APPLIANCE MARKINGS

MODULES		20 AX DP SWITCH		20 AX DP SWITCH + RED LED POWER INDICATOR	
		White	Anthracite	White	Anthracite
 <p>For other engraving requirements not listed please contact us on +44 (0) 845 605 4333</p>					
ROCKER MARKINGS	Pack				
BOILER	1	7354 20BL	7355 20BL	7354 21BL	7355 21BL
COOKER HOOD	1	7354 20CH	7355 20CH	7354 21CH	7355 21CH
DISH WASHER	1	7354 20DW	7355 20DW	7354 21DW	7355 21DW
EXTRACTOR	1	7354 20EX	7355 20EX	7354 21EX	7355 21EX
EXTRACTOR FAN	1	7354 20EF	7355 20EF	7354 21EF	7355 21EF
EXTRACTOR HOOD	1	7354 20EH	7355 20EH	7354 21EH	7355 21EH
FAN	1	7354 20FN	7355 20FN	7354 21FN	7355 21FN
FREEZER	1	7354 20FZ	7355 20FZ	7354 21FZ	7355 21FZ
FRIDGE	1	7354 20FR	7355 20FR	7354 21FR	7355 21FR
FRIDGE FREEZER	1	7354 20FF	7355 20FF	7354 21FF	7355 21FF
HEATER	1	7354 20HR	7355 20HR	7354 21HR	7355 21HR
HOB	1	7354 20HB	7355 20HB	7354 21HB	7355 21HB
HOOD	1	7354 20HD	7355 20HD	7354 21HD	7355 21HD
LIGHTS	1	7354 20LG	7355 20LG	7354 21LG	7355 21LG
MICROWAVE	1	7354 20MW	7355 20MW	7354 21MW	7355 21MW
OVEN	1	7354 20OV	7355 20OV	7354 21OV	7355 21OV
PLINTH HEATER	1	7354 20PH	7355 20PH	7354 21PH	7355 21PH
TOWEL RAIL	1	7354 20TR	7355 20TR	7354 21TR	7355 21TR
TUMBLE DRYER	1	7354 20TD	7355 20TD	7354 21TD	7355 21TD
WASHING MACHINE	1	7354 20WM	7355 20WM	7354 21WM	7355 21WM
WASTE DISPOSAL	1	7354 20WD	7355 20WD	7354 21WD	7355 21WD
WATER HEATER	1	7354 20WH	7355 20WH	7354 21WH	7355 21WH

# Synergy® grid system

installation options : flush and surface mounting

## Flush mounting installation examples

### 2 modules

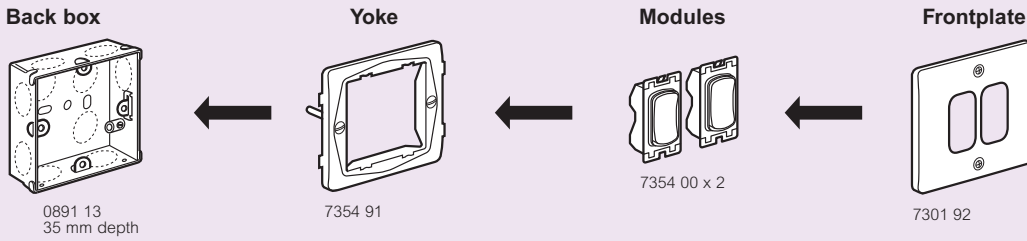

### 8 modules

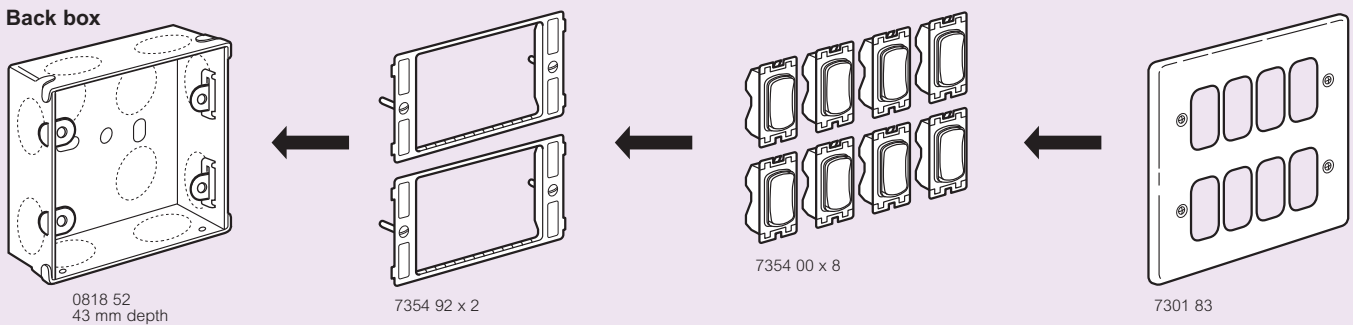

### 18 modules

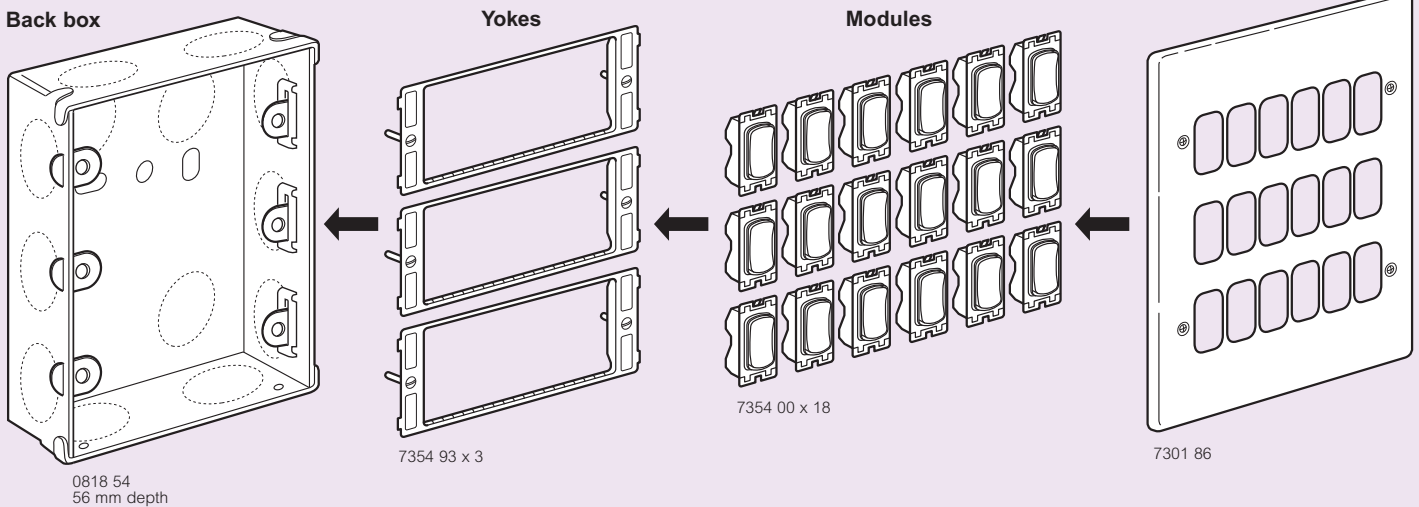

## Surface mounting installations

Surface mounting of Synergy grid modules can be achieved by using components illustrated in the table below

	1 or 2 modules	3 or 4 modules	6 or 8 modules	9 or 12 modules
<b>Box dimensions</b>				
<b>Surface box (no knockouts)</b>	7364 00	7364 01	7364 18	7364 28
<b>Surface box (with knockouts)</b>	7364 20	7364 21	7364 22	7364 32

## Yoke selection for front plates (1-4 modules)

Yokes required for clip-on plates differ from yokes for screw-attached faceplates

Yokes required for Modern clip-on plates are Cat. Nos. 7354 81 (1 or 2 modules) and 7354 82 (3 or 4 modules)

Yokes required for white, traditional and metalclad plates (screw attached) are Cat. Nos. 7354 90 (1 module), 7354 91 (2 modules), and 7354 92 (3 or 4 modules)

# Synergy® grid system

GRID MODULES	ARCHITRAVES		FRONT PLATES WITH SMALL APERTURES			
	1 gang	2 gang	1 gang		2 gang	
FRONT PLATES	1 module	2 modules	1 module	2 modules	3 modules	4 modules
PLATE FINISH	Pack	Pack	Pack	Pack	Pack	Pack
Dimensions (mm)	<b>86 x 36</b>	<b>146 x 36</b>	<b>86 x 86</b>	<b>86 x 86</b>	<b>86 x 146</b>	<b>86 x 146</b>
White	10 7301 80	10 7301 81	10 7301 91	10 7301 92	10 7301 93	10 7301 94
Traditional brushed stainless steel	1 7331 80	1 7331 81	1 7331 91	1 7331 92	1 7331 93	1 7331 94
Traditional polished stainless steel	1 7333 80	1 7333 81	1 7333 91	1 7333 92	1 7333 93	1 7333 94
Metalclad	- -	- -	1 7339 91	1 7339 92	1 7339 93	1 7339 94
Dimensions (mm)			<b>89 x 89<sup>1</sup></b>	<b>89 x 89<sup>1</sup></b>	<b>89 x 149<sup>1</sup></b>	<b>89 x 149<sup>1</sup></b>
Modern silver	- -	- -	1 7311 91	1 7311 92	1 7311 93	1 7311 94
Modern nickel	- -	- -	1 7313 91	1 7313 92	1 7313 93	1 7313 94
GRID YOKES	1 x	1 x	1 x	1 x	1 x	1 x
For white, traditional and metalclad	1 7354 95	1 7354 96	10 7354 90	10 7354 91	10 7354 92	10 7354 92
For modern	- -	- -	10 7354 81	10 7354 81	10 7354 82	10 7354 82
BACK BOXES						
FLUSH MOUNTING						
Dimensions (mm)	<b>82 x 28 x 26</b>	<b>142 x 28 x 26</b>	<b>35 mm depth</b>	<b>35 mm depth</b>	<b>35 mm depth</b>	<b>35 mm depth</b>
Flush	5 7364 40	5 7364 41	50 0891 13	50 0891 13	40 0891 14	40 0891 14
Flush with phase barriers	- -	- -	- -	- -	- -	- -
SURFACE MOUNTING						
Dimensions (mm)			<b>86 x 86 x 47</b>	<b>86 x 86 x 47</b>	<b>86 x 146 x 47</b>	<b>86 x 146 x 47</b>
Surface white for white only	- -	- -	10 7364 07	10 7364 07	5 7364 11	5 7364 11
Dimensions (mm)			<b>86 x 86 x 37</b>	<b>86 x 86 x 37</b>	<b>86 x 146 x 37</b>	<b>86 x 146 x 37</b>
Surface steel with knockouts	- -	- -	10 7364 00	10 7364 00	5 7364 01	5 7364 01
Surface steel without knockouts	- -	- -	10 7364 20	10 7364 20	5 7364 21	5 7364 21

### Front plate material

**White** : 1 to 8 modules - thermoset; 9 to 24 modules - stainless steel  
**Traditional** : All modules - stainless steel  
**Metalclad** : 1 to 4 modules - mild steel; 6 to 24 modules - stainless steel  
**Modern** : 1 to 4 modules - die cast alloy; 6 to 8 modules - stainless steel

1 : Screw free clip-on front plate

**FRONT PLATES WITH SMALL APERTURES**

		2 x 2 gang		3 x 2 gang				3 x 3 gang		4 x 3 gang			
		6 modules		8 modules		9 modules		12 modules		18 modules		24 modules	
Pack		Pack		Pack		Pack		Pack		Pack		Pack	
		146 x 146		146 x 146		207 x 146		207 x 146		267 x 206		267 x 206	
10	7301 82	10	7301 83	1	7301 84	1	7301 85	1	7301 86	1	7301 87	1	7301 87
1	7331 82	1	7331 83	1	7331 84	1	7331 85	1	7331 86	1	7331 87	1	7331 87
1	7333 82	1	7333 83	1	7333 84	1	7333 85	1	7333 86	1	7333 87	1	7333 87
1	7339 82	1	7339 83	1	7339 84	1	7339 85	1	7339 86	1	7339 87	1	7339 87
		146 x 146		146 x 146		207 x 146		207 x 146		267 x 206		267 x 206	
1	7311 82	1	7311 83	1	7311 84	1	7311 85	1	7311 86	1	7311 87	1	7311 87
1	7313 82	1	7313 83	1	7313 84	1	7313 85	1	7313 86	1	7313 87	1	7313 87
		2 x		2 x		3 x		3 x		3 x		4 x	
10	7354 92	10	7354 92	10	7354 92	10	7354 92	10	7354 93	10	7354 93	10	7354 93
10	7354 92	10	7354 92	10	7354 92	10	7354 92	10	7354 93	10	7354 93	10	7354 93
		137 x 137 x 43		137 x 137 x 43		198 x 137 x 43		198 x 137 x 43		254 x 194 x 56		254 x 194 x 56	
1	0818 52	1	0818 52	1	0818 53	1	0818 53	1	0818 54	1	0818 55	1	0818 55
	-		-	1	0818 57	1	0818 57	1	0818 58	1	0818 59	1	0818 59
		-		-		-		-		-		-	
		146 x 146 x 37		146 x 146 x 37		207 x 146 x 37		207 x 146 x 37					
1	7364 18	1	7364 18	1	7364 28	1	7364 28		-		-		-
1	7364 22	1	7364 22	1	7364 32	1	7364 32		-		-		-

2 : Phase barrier variant shown



# Clipper...

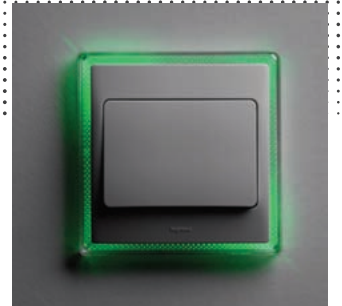

## ... a fresh look for a much loved classic

Marrying smooth curves with a slim profile and no visible screws, Legrand's Clipper range has a simple, understated appearance.

Its larger rocker, contrast colour frames and LED locators make it the ideal choice for assisted living installations and to aid with Part M compliance.



## Clipper large rocker switches



2810 01



2810 03



2810 05

Conform to BS EN 60669-1  
 Front plates : polycarbonate  
 Dimensions : 86.5 x 86.5 x 10.5 mm  
 Flush mounting back box : min. 25 mm deep

### Pack Cat. Nos. Single pole large rocker plate switches 10 AX - 250 V~

Pack	Cat. Nos.	Switch Type	Description
10 4	2810 01		1 gang – 2 way
	2810 08		1 gang – 2 way intermediate
10	2810 03		2 gang – 2 way
10	2810 05		3 gang – 2 way

### Pack Cat. Nos. Single pole large rocker push switch 10 AX - 250 V~

Pack	Cat. Nos.	Switch Type	Description
10	2810 41		1 gang – 2 way push switch

### Accessories

Pack	Cat. Nos.	Accessory	Description
1	2819 08		Silver surround frame
1	1200		Neon surround frame

## flush mounting steel back boxes



0891 10



0891 13

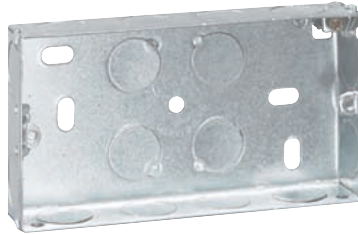

0891 11

### Pack Cat. Nos. Flush mounting back boxes

Pack	Cat. Nos.	Box Type	Description
100	0891 09		1 gang with 1 fixed lug, 1 adjustable lug and 1 earth terminal
		<b>Depth 16 mm</b>	
50	0891 10		1 gang with 3 fixed lugs, 1 adjustable lug and 1 earth terminal
		<b>Depth 25 mm</b>	
10	0891 11		2 gang with 1 fixed lug, 1 adjustable lug and 1 earth terminal
50	0891 13		1 gang with 3 fixed lugs, 1 adjustable lug and 1 earth terminal
		<b>Depth 35 mm</b>	
40	0891 14		2 gang with 1 fixed lug, 1 adjustable lug and 1 earth terminal
40	0891 40		Dual box with 2 earth terminals Accepts 2 single gang accessories
25	0891 17		1 gang with 3 fixed lugs, 1 adjustable lug and 1 earth terminal
		<b>Depth 48 mm</b>	
20	0891 18		2 gang with 1 fixed lug, 1 adjustable lug and 1 earth terminal

### Architrave back boxes

Pack	Cat. Nos.	Box Type	Description
5	7364 40		Dimensions : 82 x 28 mm
		<b>Depth 26 mm</b>	
5	7364 41		Dimensions : 142 x 28 mm
		<b>Depth 26 mm</b>	



# SETTING THE STANDARD for non standard applications

Electrak's range of non standard unswitched twin socket outlets combined with their unique 'key plugs', offer a convenient and safe method of preventing unauthorised disconnection or use of equipment.

Easy to wire key plugs twist fit into the double shuttered safety socket, removing the risk of accidental unplugging.

Available in three types:

- Clean earth
- Electronic point of sale (EPOS)
- Uninterrupted power supply (UPS)



Key plugs twist fit into the socket, removing the risk of accidental unplugging



# Electrak® wiring accessories



AZ0010



ES6000



UPS600



AP13-WH

T.S.O. Rating 240 V AC 26 A (2 x 13 A) 50 Hz  
Cable capacity 3 x 2.5 or 2 x 4mm<sup>2</sup>  
Electrak accessories are ASTA Approved to BS 5733

### Conductor :

High conductivity copper  
Insulator - Noryl ENV 130  
Brass terminals

### Plug :

Fitted with BS 1362 fuse  
Brass pins and terminals  
Polycarbonate plug housing  
Polyester plug entry box

### Socket :

Polycarbonate cover plate

Pack	Cat. Nos.	Unswitched twin socket outlets
1	White AZ0010	<b>Unswitched twin socket</b> Alternative to conventional socket outlets where non-standard applications are beneficial such as computer integrity, electronic equipment or just for the safety of the unique simple twist action double shutter access For use with Cat. No. AP13-WH plug below
1	Red CZ9010	<b>Unswitched twin socket - clean earth</b> Non-interchangeable
<b>Plugs</b>		
1	AP13-WH	<b>13 A fused plug</b> Easy to wire 'key plugs' simply twist into the double shuttered safety sockets and are fitted with standard 13 A BS 1362 fuses BS 1362 fuses less than 13 A may be fitted by the user to suit the recommended fuse size for each appliance
1	EP13 Red	<b>13 A fused plug - clean earth</b>
<b>Accessory</b>		
1	AZ0050	Electrak to 3 pin (BS 1363) socket converter

Pack	Cat. Nos.	EPOS packs (Electronic Point of Sale)
<b>EPOS packs</b>		
The twin socket outlet is unique and the key plugs are non-interchangeable with other socket outlets which stops unauthorised use of equipment Moulded in red polycarbonate For use with Cat. No. EP2000 plug below		
1	Red ES6000	Includes : unswitched twin socket and 2 x 5 A fused plugs
1	ES6005	Includes : unswitched twin socket and 1 x 5 A fused plug
<b>Plug</b>		
1	EP2000	EPOS 5 A fused plug
<b>UPS packs (Uninterruptible Power Supply)</b>		
<b>UPS packs</b>		
The twin socket outlet is unique and the key plugs are non-interchangeable with other socket outlets which stops unauthorised use of equipment Moulded in blue polycarbonate For use with Cat. No. UPS200 plug below		
1	Blue UPS600	Includes : unswitched twin socket and 2 x 3 A fused plugs
1	UPS615	Includes : unswitched twin socket and 1 x 3 A fused plug
<b>Plug</b>		
1	UPS200	UPS 3 A fused plug

# Plexo IP 55 and IP 66...



## ... safety in numbers

Whatever the weather, Plexo offers maintained and non-maintained IP 55 and IP 66 solutions to meet the specific needs of any environment.

### Perfect protection, wherever you need it

Together, Plexo's IP 55 and IP 66 ranges provide a complete weatherproof solution. Additional functionality is also available with a selection of modular housings that accommodate Arteor modular devices.



For Arteor modules  
see p. 111 - 131



Modular options for surface mounting

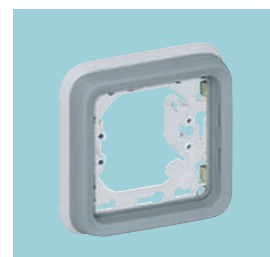

... and flush mounting



Silicon groove and flexible cable entry



Socket design accepts moulded plugs

# Plexo

## IP 66 weatherproof wiring devices



6846 03



6846 19



6846 29



5721 11



5721 11

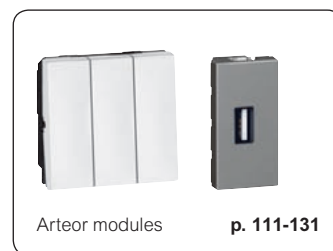

Arteor modules

p. 111-131

IP 66 - IK 08  
 Grey RAL 7016 / TO 29  
 Polypropylene/ABS housing  
 Temperature rating : -20 to +40 °C (+50 °C for short periods)  
 Provision for 20 mm dia. conduit entries (side and rear)  
 Stainless steel captive terminal screws supplied in backed-off position

Pack	Cat. Nos.	Switches - 250 V $\sim$	
		<b>20 A switches</b>	
	Grey	Conform to BS EN 60669-1 Fitted with rear gasket with groove to deposit silicone	
1	6846 03		1 gang - 2 way SP
1	6846 04		2 gang - 2 way SP

Pack	Cat. Nos.	13 A - 250 V $\sim$ socket outlets	
		Conform to BS 1363 : Part 2 Fitted with rear gasket with groove to deposit silicone	
1	6846 19		1 gang unswitched
1	6846 29		2 gang switched

Pack	Cat. Nos.	13 A - 250 V $\sim$ fused spur unit	
		Conforms to BS 1363 : Part 4 Fitted with rear gasket with groove to deposit silicone	
1	6846 45		1 gang DP switched

Pack	Cat. Nos.	Adaptors for Arteor modules	
		Fitted with rear gasket with groove to deposit silicone No additional yoke required	
1	6846 36		2 module adaptor with semi-transparent lid
1	6846 38		3 module adaptor with semi-transparent lid

Pack	Cat. Nos.	British Standard 13 A socket	
		Shuttered for child safety 13 A - BS 1363 : Part 2 Fits into Arteor module adaptors (Cat. Nos. 6846 36 and 6846 38 above)	
10	5721 11		2 P + $\pm$ ASTA approved

Pack	Cat. Nos.	ISO M20 cable gland	
25	0980 03		Cable gland IP 68

## Plexo

IP 55 weatherproof wiring accessories



0697 11



0697 10



0697 39

IP 55 - IK 07  
 Grey RAL 7035 / 7016  
 Polycarbonate mechanisms/ABS frames polypropylene housing  
 Temp. rating : -20 to +40 °C (+50 °C for short periods)  
 Supplied with direct piercing gland

Pack	Cat. Nos.	Switches 10 A - 250 V~	
10	0697 11		1 gang – 2 way SP
10	0697 15		2 gang – 2 way SP
10	0697 10		1 gang – 2 way SP + lens <sup>1</sup>
10	0697 17		1 gang – 1 way DP
5	0697 16		1 gang – SP intermediate

Pack	Cat. Nos.	Push button - 250 V~	
10	0697 20		2 way push button

Pack	Cat. Nos.	Socket outlets 13 A - 250 V~	
10	0697 32		1 gang – 13 A socket 2P + E screw terminals
5	0697 39		2 gang – two 13 A sockets 2P + E screw terminals

1 : Use lamps Cat. Nos. 0694 97/98

## Plexo

IP 55 modular mechanisms



0695 47



0695 34



Surface mounting boxes and flush mounting support frames for Plexo modular mechanisms **p. 203**

IP 55 - IK 07  
 Grey RAL 7035 / 7016  
 Polycarbonate/polypropylene housing  
 Temp. rating : -20 to +40 °C (+50 °C for short periods)  
 Supplied with direct piercing gland  
 Installation with surface mounting boxes or flush mounting frames

Pack	Cat. Nos.	Illuminating time lag switch - 250 V~	
5	0695 04		Electronic - IP55 2 wire connection Supplied with lamp Temporization : 25 s to 15 min.  Max. loads : - 1 000 W incandescent and halogen 230 V~ - 400 W halogen 130 V - 400 VA ELV halogen lamps - 400 VA fluorescent lamps - 2 300 W resistive (heating)

Pack	Cat. Nos.	Emergency stop functions 3 A - 230 V~	
1	0695 47		Emergency stop button 1 N/C contact 1 pole
1	0695 48		Emergency stop with key for reset N/O + N/C contact Key RONIS No. 455 supplied Key removable in 0 position
1	0695 49		Emergency stop - stay put 1/4 turn release N/O + N/C contact Key removable in 0 position

Pack	Cat. Nos.	Key operated switches 3 A - 250 V~	
1	0695 34		2 positions marked "0 - I" 2 N/O contacts
1	0695 35		2 positions marked "I - 0 - II" 2 N/O contacts

# Plexo

## IP 55 modular mechanisms (continued)



IP 55 - IK 07  
 Grey RAL 7035 / 7016  
 Polycarbonate/polypropylene housing  
 Temp. rating : -20 to +40 °C (+50 °C for short periods)  
 Supplied with 1 flat + 1 stepped gland  
 Captive terminal screws supplied in backed-off position  
 Installation with surface mounting boxes or flush mounting frames

Pack	Cat. Nos.	Pilot light	
10	0695 83		Accepts E10 lamps - 5 W max. Supplied with lamp Cat. No. 0898 40 Supplied without diffusers (see below)
<b>Diffusers for pilot light</b>			
10	0695 88		Colourless
10	0695 89		Green
10	0695 90		Orange
10	0695 91		Red

Light sensitive switches - 230 V~			
<b>Light sensitive switch 1 function IP 55 - IP 07</b>			
5	0695 17		Can be used to switch a lighting circuit "ON" and "OFF" based on light conditions (nightfall, daybreak) Supplied in one piece, including photo electric cell Maximum load : - 1400 W incandescent and halogen lamps 230 V~ - 400 VA fluorescent tubes Luminosity threshold : 0.5 to 1500 lux
<b>Photo-electric cell IP 55</b>			
5	0695 18		For use with modular Microlux D light sensitive switch Cat. No. 0037 21 (see below)
<b>Microlux D light sensitive switch</b>			
			Controls lighting according to the time and light level Supply voltage : 230 V~ ±10% 50/60 Hz Working reserve : 100 hours Accuracy of time switch : 1 second per day Number of programmes : 28/14 per channel Range of light intensity : 2-60 000 lux Switching step : 1 minute Manual switch : override/programme/stop Automatic changeover to summer/winter time Temporary override with automatic return to programme
1	0037 21		10 A - 250 V~ cos φ = 1 1 changeover contact with 60 sec delay
			No. of 17.5 mm modules 2

Socket outlet 13 A - 250 V~			
10	0695 85		Panel mounting 1 gang - 13 A socket 2P + E screw terminals

Pack	Cat. Nos.	Back boxes and support frames	
<b>Surface mounting boxes with membrane glands</b>			
Equipped with removable membrane glands Direct entry of cables (No need to be cut)			
10	0696 51		Grey 1 gang - 1 entry
5	0696 72		2 gang - 1 entry
<b>Surface mounting boxes with membrane glands</b>			
Grey			
5	0696 56		1 gang - 1 entry
5	0696 78		2 gang, horizontal mounting - 2 entries (2 top)
<b>Flush mounting support frame</b>			
10	0696 81		1 gang For Plexo modular mechanisms

Accessories			
<b>Modular back box IP 55 - IK 05</b>			
To receive Arteor modules (max. 2 modules)			
10	0695 80		Adaptor with smoked polycarbonate flap
<b>Lamps</b>			
10	0694 98		230 V - 1 mA orange (indicator)
10	0694 97		230 V - 0.5 mA green (locator)
<b>E10 for pilot light</b>			
10	0898 40		230 V - 5 W

## ceiling switches



0611 10



0611 26 +  
8204 60



7545



7768

Pack	Cat. Nos.	Ceiling switches
		<p>Conform to BS EN 60669-1 Clearly embossed terminal markings Thermoplastic material resulting in increased mechanical strength Quick snap on cover mouldings with easily detachable cord for installation/security</p> <p>Dimensions : 80 mm diameter Fixing centres : 50·8 mm</p> <p><b>Mains voltage – white</b></p>
10	0611 10	6 A – 250 V $\sim$ SP one way with 1·5 m white cord
10	0611 11	6 A – 250 V $\sim$ SP two way with 1·5 m white cord
10	0611 30	16 A – 250 V $\sim$ DP one way with 1·5 m white cord
		<b>Extra low voltage</b> (cord not supplied)
10	0611 25	Pull to make/pull to break (non-latching) <sup>1</sup>
10	0611 26	Pull to make/pull to break with 28 V indicator and orange lens (non-latching) <sup>1</sup>

Pack	Cat. Nos.	Ceiling switch 50 A DP - 250 V $\sim$
		<p>Conforms to BS 3676 Positive ON/OFF flag indicator Red neon indicator Suitable for ceiling or wall mounting For flush mounting, use box Cat. No. 0891 17 (see p. 187)</p> <p>Dimensions : 86 x 86 mm Fixing centres : 60·3 mm</p>
10	7545	50 A DP ceiling switch
10	7768	Surface box for Cat. No. 7545 - depth 47 mm
		<b>Accessories</b>
10	0611 49	White replacement cord 1·5 m
10	8204 60	Orange cord 2·3 m and orange acorn
250	8204 69	White adaptor

1 : Outside the scope of BS EN 60669-1

## ceiling accessories

### safety lampholders and pendant sets



Pack	Cat. Nos.	Energy-saving pendant set
1	White 6603 07	<p>Conforms to EN 61000-3-2, EN 50082-1, EN 55015, EN 60929, EN 61547, EN 60928 and BS 67</p> <p>Supply voltage 230 - 240 V Mains frequency 50 Hz To be used with 13/18 W 4 pin plug-in lamps only Lamp fitting type GX24q-1 Dimming is not possible Ceiling rose has angled terminal block with clear polycarbonate shroud 8 in-line terminals with captive screws and earth terminal</p> <p>3 inch drop – energy-saving 13/18 W pendant set Lamp not supplied</p>

Pack	Cat. Nos.	Safety lampholders
20	White 0600 81	<p>T2 rated to BS 7895</p> <p>Heat resistant glass fibre reinforced PET<sup>1</sup> one-piece lampholder body Safety lampholders feature automatic isolation of brass plungers following lamp removal Plungers cannot be made live again unless lamp is in place</p> <p>B22 lampholder – short skirt</p>

Pack	Cat. Nos.	Safety lampholder + tails
20	White 8204 90	<p>T2 rated to BS 7895</p> <p>Safety lampholder + 6 inch tails</p>

Pack	Cat. Nos.	Safety batten lampholders
10	White 0600 85	<p>T2 rated to BS 7895</p> <p>Incorporate previous safety lampholders, plus : Angled terminal block with clear polycarbonate shroud Heat resistant tails to IEC 60227</p> <p>B22 lampholder – straight/short skirt 8 in-line terminals with captive screws plus earth</p>
10	0600 86	<p>B22 lampholder – straight/H.O. skirt 8 in-line terminals with captive screws plus earth</p>

Pack	Cat. Nos.	Safety pendant sets
10	White 0600 89	<p>T2 rated to BS 7895</p> <p>Combination of ceiling rose and previous safety lampholder with length of two core 0.75 mm<sup>2</sup> PVC circular flexible cable, plus : Angled terminal block with clear polycarbonate shroud 8 in-line terminals with captive screws and Heat resistant tails to IEC 60227</p> <p>6 inch drop – short skirt lampholder</p>
10	0600 90	<p>6 inch drop – H.O. skirt lampholder</p>

1 : PET – Polyethylene Terephthalate

**bathroom lighting**



Pack	Cat. Nos.	Energy-saving shaver light IP 44
1	6915 09	<p>Conforms to BS EN 60598                      Electronic ballast (IEC EN 61347) offers a further 25-30% energy saving over standard control gear                      Light source : 4 pin energy saving 18/24 W 2G lamp                      Projected 50% longer life span with immediate start-up, silent operation and flicker-free illumination                      Automatic switch off at end of the lamp's life                      Shuttered 2 pin shaver socket for use with European, British and American 2 pin plugs                      Double wound 20 VA isolating transformer                      Plexo grommet                      Suitable for Zone 2 bathroom installation                      Screwless terminal cabling supplied with 24W 2G 11</p> <p>Energy-saving shaver light                      Polycarbonate base with opal polycarbonate diffuser</p>

Pack	Cat. Nos.	Shaver light IP 24 - IK 04
1	6915 06	<p>Conforms to BS EN 60598                      Diffuser removal disconnects power supply to lamp                      Pull cord switch                      2P shuttered socket                      230 V - 20 VA isolating transformer                      Single voltage output 230 V                      Class II double isolated                      CE and ⚡ marked                      Suitable for Zone 2 bathroom installation</p> <p>Shaver light supplied with 60 W - 230 V~ 284 mm double ended striplight S15 cap Ø 25                      Polypropylene base with polycarbonate opal diffuser</p>

**bathroom lighting zoning**

**Understanding the regulations**

To conform with IEE regulations, BS 7671 : 2008, all installations should use an IPX4 rated product in zone 2 of a standard bathroom or a room containing a shower

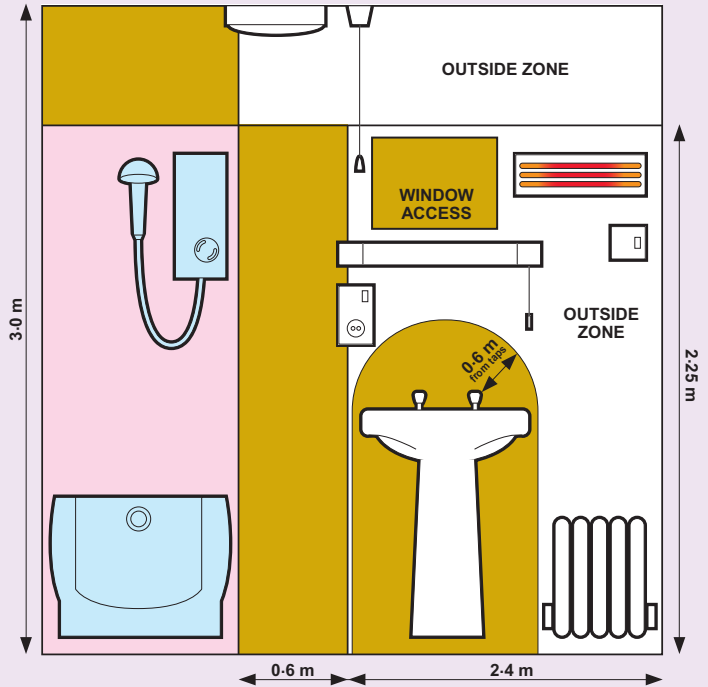

Typical bathroom showing BS 7671 : 2008 zones and dimensions

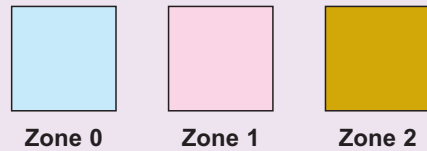

**Energy-saving shaver light IP 44**



**Shaver light IP 24 - IK 04**

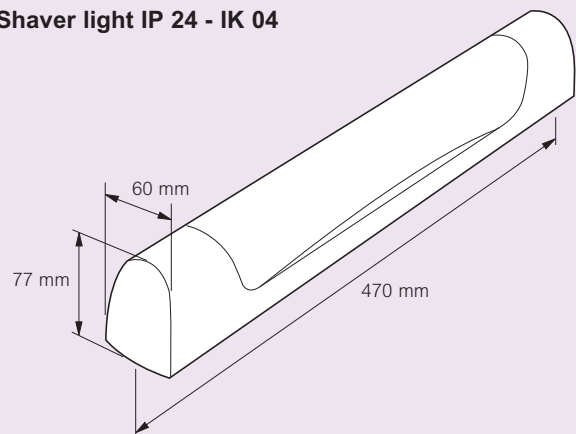



## utility weatherproof bulkhead lighting



0604 50



6604 17



6604 18

Pack	Cat. Nos.	Weatherproof round bulkhead lights
		IP 44 Conform to IS EN 60598-1 B22 lampholder Class II $\square$ (double insulated) White base Multi-purpose low profile bulkhead suitable for indoor or outdoor application Twist and lock closing Lamp not supplied <b>100 W incandescent</b>
5	0604 50	With glass diffuser
10	0604 58	With polycarbonate diffuser

Pack	Cat. Nos.	Plexo weatherproof bulkhead lights
		IP 55 - IK 08 B22 lampholder Hinged polycarbonate diffuser Top/bottom reversible opening Lamp not supplied <b>75 W incandescent</b>
5	6604 17	With clear diffuser
1	6604 18	With red diffuser

## utility weatherproof bulkhead lighting

### Weatherproof round bulkhead lights

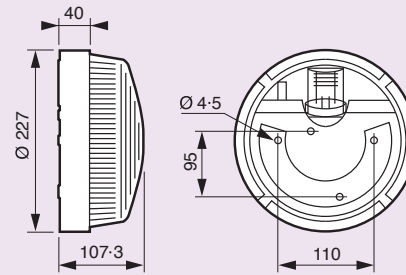

### Plexo weatherproof bulkhead lights

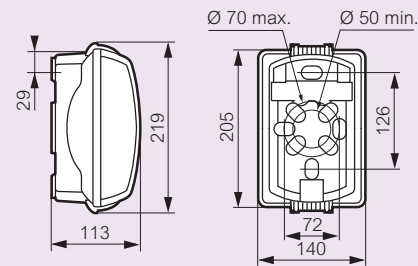

All dimensions in mm (nominal)

# Domestic circuit protection

## Consumer units



**P. 212**  
Insulated surface mounting selection chart

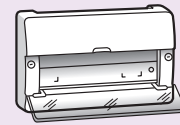

**P. 214**  
Insulated custom build



**P. 212**  
Metal surface mounting selection chart

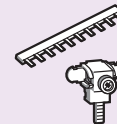

**P. 215**  
Insulated and metal accessories

## MCBs, RCDs, RCBOs and DIN rail equipment

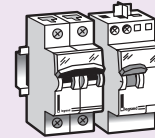

**P. 216**  
MCBs, RCDs and RCBOs

## Irish consumer units

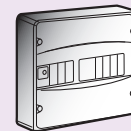

**P. 217**  
Irish consumer units

## Plexo<sup>3</sup> weatherproof (IP 65) enclosures



**P. 222** NEW  
Plexo<sup>3</sup> enclosures for DIN rail equipment

## Tenby<sup>®</sup> earth clamps

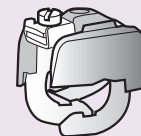

**P. 225**  
Tenby<sup>®</sup> Rapid Clamp Ultra

## NEW IN 2012



**RX<sup>3</sup> MCBs**  
(p. 216)



**Bell transformers**  
(p. 216)



**P. 213**  
Protection devices MCBs and RCBOs selection chart

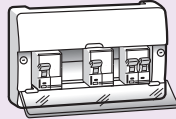

**P. 214**  
Insulated high integrity dual RCD split load

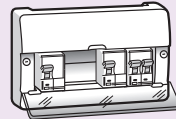

**P. 214**  
Insulated dual RCD split load

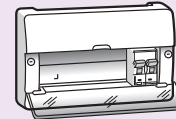

**P. 214**  
Insulated with incomer



**P. 215**  
Insulated and metal accessories



**P. 218**  
Insulated surface mounting dimensions



**P. 213**  
Protection devices MCBs and RCBOs selection chart

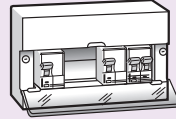

**P. 215**  
Metal dual RCD split load

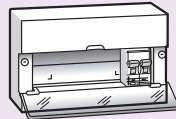

**P. 215**  
Metal with incomer

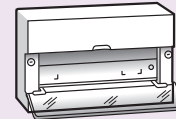

**P. 215**  
Metal custom build



**P. 219**  
Metal surface mounting dimensions

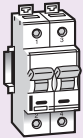

**P. 216**  
Isolating switches



**P. 216**  
Contactor

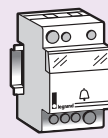

**P. 216**  
Modular bell transformers

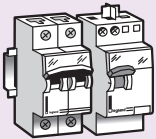

**P. 217**  
MCBs, RCDs and RCBOs

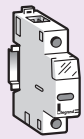

**P. 217**  
Voltage surge protector

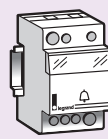

**P. 217**  
Modular bell transformers



**P. 221**  
Voltage surge protectors technical information



**P. 223**  
Dimensions

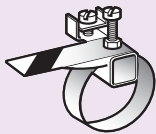

**P. 225**  
Tenby® Rapid Clamp



**Plexo<sup>3</sup>**  
weatherproof enclosures  
IP 65  
(p. 222)



# Greater protection...

With an array of design innovations and practical features Legrand's consumer units are easy to install, saving valuable time and money during installation... allowing you to reflect on the generous wiring space and the all-round extra protection.

## COMPLETE FLEXIBILITY FOR CHANGING DEMANDS

Legrand's custom build consumer units offer complete flexibility to cope with the increasing demand for dedicated circuits to protect items such as smoke detectors, photovoltaic panels and electric vehicles.



- Rigid base with multiple cut-outs
- Magnolia case with high fire retardancy. Self extinguishing at 750°C
- Removable terminal holders with screws in backed-off position
- Clear, colour-coded labelling system
- Removable pan assembly
- Rail positioned for maximum cabling space
- Smoked transparent door with smooth closing action
- Cut-to-length busbar for flexible on-site configuration
- Insulated shield

**DUAL RCD SPLIT LOAD WITH DEDICATED MAIN SWITCH WAYS**

Select MCBs and RCBOs to complete installation



**DUAL RCD SPLIT LOAD**

Select MCBs to complete installation



**SPLIT LOAD**

Select MCBs and RCBOs to complete installation



**MAIN SWITCH INCOMER**

Select RCBOs to complete installation



**RCD INCOMER**

Select MCBs to complete installation



**NEW RX<sup>3</sup> MCBs... the safer choice**

With long-lasting performance and a low watt loss rate, you can be sure that NEW RX<sup>3</sup> MCBs will keep you safe, whilst saving energy and ultimately, money.

## consumer units

insulated and metal

### Insulated consumer units

Conform to BS EN 60439-3. IP 30. RAL 9001. Magnolia colour. Smoked transparent door opens downwards  
 Supplied with neutral and earth terminals completely assembled. Supplied with 5 module spare blank plate  
 Factory fitted link leads for both neutral and live connections. Configurable outgoing ways  
 Self-extinguishing at 750 °C. UL 94 V2 material for improved flame retardancy. Robust thermoplastic construction. 4 fixing holes

 Dimensions p. 218-219	Total outgoing ways										
	2	4	6	8	10	12	14	16	18	20	22
<b>High integrity dual RCD split load with 2 unprotected ways</b> 100 A main switch and 2 x 80 A 30 mA RCD	–	–	–	–	6075 74	–	–	6075 76	–	–	–
<b>Dual RCD split load</b> 100 A main switch and 2 x 80 A 30 mA RCD	–	–	–	–	6075 54	–	–	6075 56	–	–	–
<b>Main switch incomer</b> 63 A main switch	6075 10	–	–	–	–	–	–	–	–	–	–
<b>Main switch incomer</b> 100 A main switch	–	–	6075 11	–	6075 12	–	6075 14	–	–	6075 16	–
<b>RCD incomer</b> 80 A 30 mA RCD	–	–	6075 21	–	6075 22	–	–	–	–	–	–
<b>Custom build</b>	–	6075 00	–	6075 01	–	6075 02	–	–	–	–	–

### Metal consumer units

Conform to BS EN 60439-3. IP 30. RAL 9001. Magnolia colour. Smoked transparent door opens downwards  
 Supplied with neutral and earth terminals completely assembled. Supplied with 5 module spare blank plate  
 Factory fitted link leads for both neutral and live connections. Configurable outgoing ways  
 Pre-galvanised steel for strength and rigidity. Epoxy/polyester powder coated base and lid

 Dimensions p. 219-220	Total outgoing ways									
	6	8	10	12	14	16	18	20	22	
<b>Dual RCD split load</b> 100 A main switch and 2 x 80 A 30 mA RCD	–	–	6065 54	–	–	6065 56	–	–	–	–
<b>Main switch incomer</b> 100 A main switch	6065 11	–	6065 12	–	–	–	–	–	–	–
<b>Custom build</b>	–	6065 01	–	6065 02	–	6065 04	–	–	–	6065 06

## protection devices

### MCBs and RCBOs

<b>RX<sup>3</sup> MCBs - 6 kA</b> Breaking capacity : 6 kA to BS EN 60898-1		<b>RX<sup>3</sup> residential MCBs - 6 kA</b> Single pole - 230/400 V~			<b>RCBOs (combined MCB/RCD)</b> Single pole and neutral - 240 V~	
<b>RCBOs (combined MCB/RCD)</b> Breaking capacity : 10 kA to BS EN 61009-1 RCD type AC conform to BS EN 61009-1 Terminal capacity : rigid conductor 35 mm <sup>2</sup> flexible conductor 25 mm <sup>2</sup>		 4022 70			 6064 19	
Nominal rating (In)	Pack Qty	Number of 17.5 mm modules	B curve	C curve	Number of 17.5 mm modules	30 mA B curve
6 A	10	1	4022 70	4023 10	1	6064 16
10 A	10	1	4022 71	4023 11	1	6064 17
16 A	10	1	4022 72	4023 13	1	6064 18
20 A	10	1	4022 73	4023 14	1	6064 19
25 A	10	1	4022 74	4023 15	–	–
32 A	10	1	4022 75	4023 16	1	6064 20
40 A	10	1	4022 76	4023 17	1	6064 21
50 A	10	1	4022 77	4023 18	1	6064 28
63 A	10	1	4022 78	4023 19	–	–

## insulated consumer units

### surface mounting



6075 74



6075 54



6075 10



6075 21

#### Dimensions p. 218-219

Conform to BS EN 60439-3. IP 30. RAL 9001 - magnolia colour  
 Self-extinguishing at 750 °C - UL 94 V2 material for improved flame retardancy  
 Robust, rigid thermoplastic construction with 4 fixing holes  
 Smoked transparent door opens downwards  
 Supplied with neutral and earth terminals completely assembled  
 Supplied with 5 module spare blank plate (except 4 module unit)  
 MCBs to be ordered separately, (see p. 216)  
 Rigid base with multiple cut-outs  
 Removable terminal holders with screws in backed-off position  
 Insulated shield  
 Cut-to-length busbar  
 Removable pan assembly

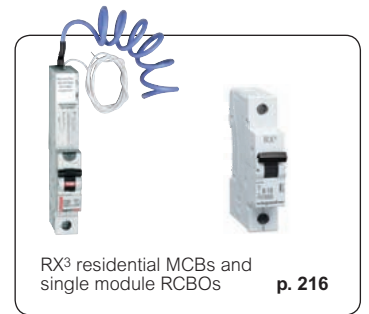

#### Pack Cat. Nos. **Insulated high integrity dual RCD split load with 2 unprotected ways - surface mounting**

Pack	Cat. Nos.	Description
1	6075 74	<b>16 module unit</b> (8 + 2 ways available) With 100 A main switch and 2 x 80 A 30 mA RCD
1	6075 76	<b>22 module unit</b> (13 + 3 ways available) With 100 A main switch and 2 x 80 A 30 mA RCD

#### Pack Cat. Nos. **Insulated dual RCD split load - surface mounting**

Pack	Cat. Nos.	Description
1	6075 54	<b>16 module unit</b> (10 ways available) With 100 A main switch and 2 x 80 A 30 mA RCD
1	6075 56	<b>22 module unit</b> (16 ways available) With 100 A main switch and 2 x 80 A 30 mA RCD

#### Accessories

Pack	Cat. Nos.	Description
1	8218 57	<b>Lockable brackets</b> For 16 module unit
1	8218 58	For 22 module unit
3	0044 43	<b>Padlock</b> Ø 4 mm

#### Pack Cat. Nos. **Insulated with incomer - surface mounting**

Pack	Cat. Nos.	Description
1	6075 10	<b>4 module unit</b> With 63 A main switch (2 ways available)
1	6075 11	<b>8 module unit</b> With 100 A main switch (6 ways available)
1	6075 21	With 80 A 30 mA RCD (6 ways available)
1	6075 12	<b>12 module unit</b> With 100 A main switch (10 ways available)
1	6075 22	With 80 A 30 mA RCD (10 ways available)
1	6075 14	<b>16 module unit</b> With 100 A main switch (14 ways available)
1	6075 16	<b>22 module unit</b> With 100 A main switch (20 ways available)

#### Insulated custom build - surface mounting

Pack	Cat. Nos.	Description
1	6075 00	Allow several configurations when using kits and incomers (isolating switches, RCDs, RCBOs) For kits, (see p. 215)
1	6075 01	For incomers and outgoing devices, (see p. 216)
1	6075 02	4 modules available
1	6075 01	8 modules available
1	6075 02	12 modules available



## metal consumer units surface mounting



6065 06



6065 54



Dimensions p. 219-220

Conform to BS EN 60439-3. IP 30. RAL 9001 - magnolia colour  
Pre-galvanised steel for strength and rigidity  
Smoked transparent door opens downwards  
Supplied with neutral and earth terminals completely assembled  
Supplied with 5 module spare blank plate  
MCBs to be ordered separately, (see p. 216)

Pack	Cat. Nos.	Metal dual RCD split load - surface mounting
1	6065 54	<b>16 module unit</b> (10 ways available) With 100 A main switch and 2 x 80 A 30 mA RCD
1	6065 56	<b>22 module unit</b> (16 ways available) With 100 A main switch and 2 x 80 A 30 mA RCD
<b>Metal with incomer - surface mounting</b>		
Epoxy/polyester powder coated base and lid Stand-off feet complete with keyhole fixing		
1	6065 11	<b>8 module unit</b> With 100 A main switch (6 ways available)
1	6065 12	<b>12 module unit</b> With 100 A main switch (10 ways available)
<b>Metal custom build - surface mounting</b>		
Epoxy/polyester powder coated base and lid Stand-off feet complete with keyhole fixing Allow several configurations when using kits and incomers (isolating switches, RCDs, RCBOs) For kits, (see opposite) For incomers and outgoing devices, (see p. 216)		
1	6065 01	8 modules available
1	6065 02	12 modules available
1	6065 04	16 modules available
1	6065 06	22 modules available

## accessories for insulated and metal consumer units

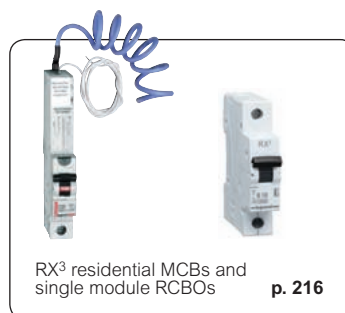

RX<sup>3</sup> residential MCBs and single module RCBOs

p. 216

Pack	Cat. Nos.	Accessories
1	6075 19	<b>Incomer or dual tariff kit</b> Comprises : 1 flexible neutral (blue) lead 1 rigid neutral link
1	6075 39	<b>Split load kit</b> Comprises : 1 flexible live (brown) lead 1 flexible neutral (blue) lead 2 rigid neutral links
1	6075 49	<b>Split load dual tariff kit (for insulated units only)</b> Comprises : 1 flexible live (brown) lead 2 flexible neutral (blue) leads 2 rigid neutral links 1 neutral terminal
20	6075 89	<b>Spare blank plate</b> 5 modules - magnolia colour
5	6075 99	<b>Spare busbar</b> 21 prongs
10	0044 40	<b>Spacing elements</b> 0.5 module
5	0044 41	1 module
2	0044 42	<b>Locking device for MCBs and RCDs</b> Locking attachment for Ø 4 mm and Ø 6 mm padlocks
1/3	0044 43	<b>Padlock for MCBs and RCDs</b> Padlock Ø 4 mm
1	8204 07	<b>Spare terminal block</b> 13 hole
<b>Finishing accessories</b>		
10	0016 64	<b>White blanking plate RAL 9010</b> 18 module, separable by single or half modules
10	0049 96	<b>Self-adhesive label holder</b> Width : 16 mm Width available for marking : 12 mm Length 530 mm (24 modules)

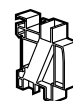

0044 41



0049 96

# protection and control devices

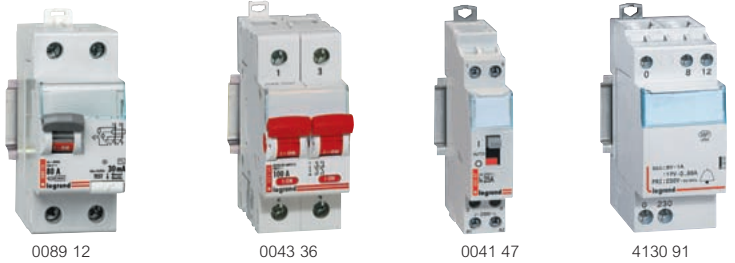

Pack	Cat. Nos.		<b>RX<sup>3</sup> residential MCBs - 6 kA</b>	
			Breaking capacity : 6 kA to BS EN 60898-1	
			<b>Single pole - 230/400 V<math>\sim</math></b>	
	B curve	C curve	Nominal rating (In)	Number of 17.5 mm modules
10	4022 70	4023 10	6 A	1
10	4022 71	4023 11	10 A	1
10	4022 72	4023 13	16 A	1
10	4022 73	4023 14	20 A	1
10	4022 74	4023 15	25 A	1
10	4022 75	4023 16	32 A	1
10	4022 76	4023 17	40 A	1
10	4022 77	4023 18	50 A	1
10	4022 78	4023 19	63 A	1

B	C	Cat. Nos.		<b>DX multi-purpose MCBs - 6 kA</b>	
				Breaking capacity : 6 kA to BS EN 60898-1	
				<b>Single pole - 230/400 V<math>\sim</math></b>	
		B curve	C curve	Nominal rating (In)	Number of 17.5 mm modules
10	1	0061 56	0063 72	6 A	1
10	10	0061 58	0063 74	10 A	1
10	10	0061 60	0063 76	16 A	1
10	1	0061 61	0063 77	20 A	1
10	1	0061 63	0063 79	32 A	1
1	1	0061 64	0063 80	40 A	1
1	1	0061 65	0063 81	50 A	1
1	1	0061 66	0063 82	63 A	1

Pack		Cat. Nos.		<b>RCBOs (combined MCB/RCD) - Single module</b>	
				Breaking capacity : 10 kA to BS EN 61009-1	
				RCD type AC conform to BS EN 61009-1	
				Terminal capacity : rigid conductor 35 mm <sup>2</sup> flexible conductor 25 mm <sup>2</sup>	
				<b>Single pole and neutral - 240 V<math>\sim</math></b>	
		B curve		Nominal rating (In)	Number of 17.5 mm modules
1		6064 16		6 A	1
1		6064 17		10 A	1
1		6064 18		16 A	1
1		6064 19		20 A	1
1		6064 20		32 A	1
1		6064 21		40 A	1
1		6064 28		50 A	1

Pack	Cat. Nos.		<b>DX residual current devices (RCDs)</b>	
			Conform to BS EN 61008-1	
			Terminal capacity : rigid conductor 35 mm <sup>2</sup> flexible conductor 25 mm <sup>2</sup>	
			<b>Double pole 230 V<math>\sim</math></b>	
	Type AC		Nominal rating (In)	Number of 17.5 mm modules
			<b>30 mA</b>	
1	0089 09		25 A	2
1	0089 10		40 A	2
1	0089 11		63 A	2
1	0089 12		80 A	2
1	6027 10		100 A	2
			<b>100 mA</b>	
1	0089 15		25 A	2
1	0089 16		40 A	2
1	0089 17		63 A	2
1	0089 18		80 A	2
1	6027 11		100 A	2

Pack		Cat. Nos.		<b>Isolating switches</b>	
				Conform to BS EN 60947-3, IEC 60669-1	
				Usage : AC 22 according to IEC 60947-3	
				Red handle	
				Double break contacts, padlockable	
				50 mm <sup>2</sup> capacity shielded terminals	
				Number of 17.5 mm modules	
5		0043 31	63 A double pole	2	
5		0043 36	100 A double pole	2	

Pack		Cat. Nos.		<b>Contactor with 230 V<math>\sim</math> coil</b>	
				Conforms to EN 61095	
				<b>Double pole (L + N) 250 V<math>\sim</math></b>	
				230 V $\sim$ coil circuit	
		I max.		Type of contact	Number of 17.5 mm modules
1		25 A		2 N/O	1

**For other contactors, see current Industrial and Power Protection catalogue**

Pack		Cat. Nos.		<b>Bell transformers</b>	
				Conform to IEC/EN 61558-2-8	
				Supplied with label holder	
				Protected against overloads and short circuits	
				Power to 8 V-12 V or 24 V access control devices such as bells and chimes	
				Possibility for supply busbars to run through (Cat. Nos. 4130 90/91)	
		Secondary (V)	Rating (A)	Power (VA)	Number of 17.5 mm modules
		<b>230 V / 8 V</b>			
1		8 V $\sim$	0.5 A	4 VA	2
		<b>230 V / 12 V - 8 V</b>			
1		12/8 V $\sim$	0.66/1 A	8 VA	2
		<b>230 V / 24 V - 12 V</b>			
1		24/12 V $\sim$	1/1.5 A	24/18 VA	4

# Irish consumer units

## protection devices and modular devices



Voltage surge protection technical information p. 221

Pack	Cat. Nos.	Insulated consumer units	
		IEC 60439 – IP30 – IK05 – Class 2 ◻ 230 V 50Hz operating voltage Surface mounting Supplied completely assembled with neutral and earth terminals Insulated reversible back plate and door Colour : white RAL 9010 Supplied complete with a set of pre-printed labels in English and Irish for use with MCBs and RCDs Supplied with blanking plates	
		Each consumer unit is fitted with : • 63 A Neozed fuse unit complete with fuse • 2 x 10 A type B MCBs • 32 A type B MCB • 63 A 30 mA RCD • 4 x 20 A type B MCBs	
			Dimensions (mm) Height x Width x Depth
1	6010 60	1 row unit	235 x 250 x 120
1	6010 61	2 row unit	360 x 250 x 120
1	6010 62	3 row unit	485 x 250 x 120

Pack	Cat. Nos.	Accessories	
		<b>White doors</b>	
1	0013 31	For 1 row unit	
1	0013 32	For 2 row unit	
		<b>Transparent doors</b>	
1	0013 41	For 1 row unit	
1	0013 42	For 2 row unit	
		<b>Joining accessories</b>	
		Consisting of spacers and an arched cable gland for joining 2 units together	
1	0013 92	Vertical (across whole width)	

Pack	Cat. Nos.	RX <sup>3</sup> residential MCBs - 6 kA	
		Short circuit capacity : 6 000 A (IS EN 60898-1) Type B – 6 kA	
		<b>Single pole</b> (1 protected pole) <b>230/400 V</b> ~	
		B curve	
		Nominal rating (In)	Number of 17.5 mm modules
10	4022 71	10 A	1
10	4022 73	20 A	1
10	4022 75	32 A	1
10	4022 76	40 A	1

**Specials available on request**

**Please note :** The products shown on this page represent the most commonly used items in the range. Additional versions, including surface and flush boards, are also available on request.

1 : Min. protection for Icc max : 10 kA

Pack	Cat. Nos.	Residual current devices (RCDs)		
		Type AC Conform to IS EN 61008-1		
		Type AC	Nominal rating (In)	Number of 17.5 mm modules
		<b>Double pole 230 V</b> ~		
		<b>30 mA sensitivity</b>		
1	0086 29	40 A	2	
1	0086 30	63 A	2	
		<b>DX RCBOs - 10 kA</b>		
		Conform to BS EN 61009-1 Breaking capacity : 10 kA to BS EN 61009-1 Type B MCB and 30 mA RCD protection		
		B curve	Nominal rating (In)	Number of 17.5 mm modules
1	0077 78	10 A	2	
1	0077 80	16 A	2	
1	0077 81	20 A	2	
1	0077 83	32 A	2	
1	0077 84	40 A	2	

Pack	Cat. Nos.	Voltage surge protector		
		For neutral earthing : TT, TN, IT, U <sub>e</sub> = 440 V Type 1 : I <sub>imp</sub> = 10 kA (impulse discharge cap. 10/350 µs wave) Type 2 : I <sub>n</sub> = 20 kA; U <sub>p</sub> = 2 kV (protection level) I <sub>max</sub> = 70 kA (impulse discharge cap. 8/20 µs)		
		Associated protection	Number of 17.5mm modules	
1	0039 20	Single pole	0068 64	1

Pack	Cat. Nos.	Bells and buzzer				
		50 Hz AC Connection by screw terminals, with label holder				
		<b>Bells - IP 30-1</b>				
		Voltage (V ~)	Power (VA)	Consum. (mA)	p 1 (dB)	Number of 17.5 mm modules
10	0041 01	8/12	4/5	360/420	80/84	1
10	0041 07	230	6	27	83	1
		<b>Buzzer - IP 30-1</b>				
10	0041 13	230	6	27	73	1

Pack	Cat. Nos.	Bell transformers			
		Conform to IEC/EN 61558-2-8 Supplied with label holder Protected against overloads and short circuits Power to 8 V-12 V or 24 V access control devices such as bells and chimes Possibility for supply busbars to run through (Cat. Nos. 4130 90/91)			
		Secondary (V)	Rating (A)	Power (VA)	Number of 17.5 mm modules
		<b>230 V / 8 V</b>			
1	4130 90	8 V~	0.5 A	4 VA	2
		<b>230 V / 12 V - 8 V</b>			
1	4130 91	12/8 V~	0.66/1 A	8 VA	2
		<b>230 V / 24 V - 12 V</b>			
1	4130 93	24/12 V~	1/1.5 A	24/18 VA	4

**Spare terminals available** (see current Industrial and power protection catalogue)  
**Modular timers** (p. 26)

# insulated consumer units

## surface mounting

### Insulated - surface mounting dimensions (mm)

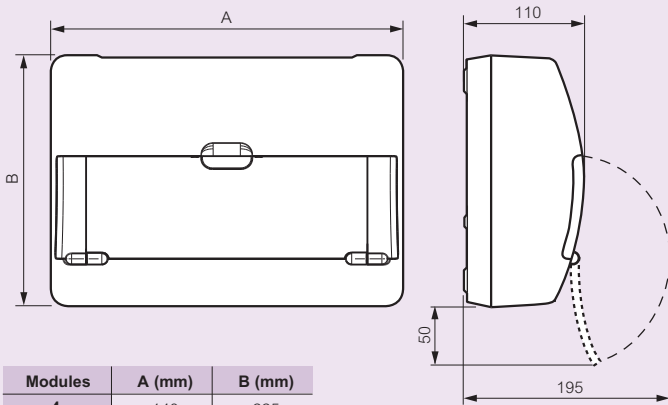

Modules	A (mm)	B (mm)
4	140	225
8	212	225
12	298	225
14/16	370	225
20/22	478	225

### 4 module unit

#### Back box fixing centres and cable entries (mm)

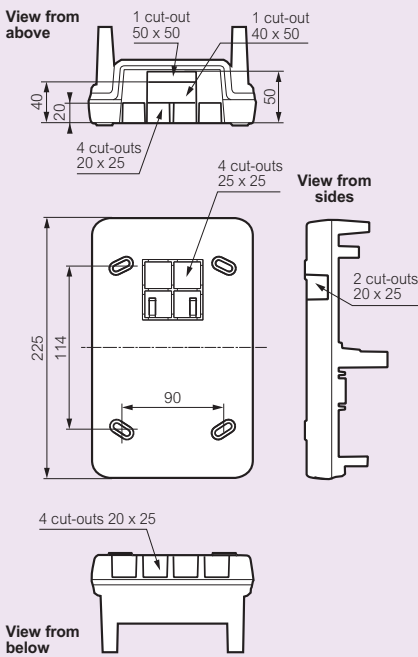

### 8 module unit

#### Back box fixing centres and cable entries (mm)

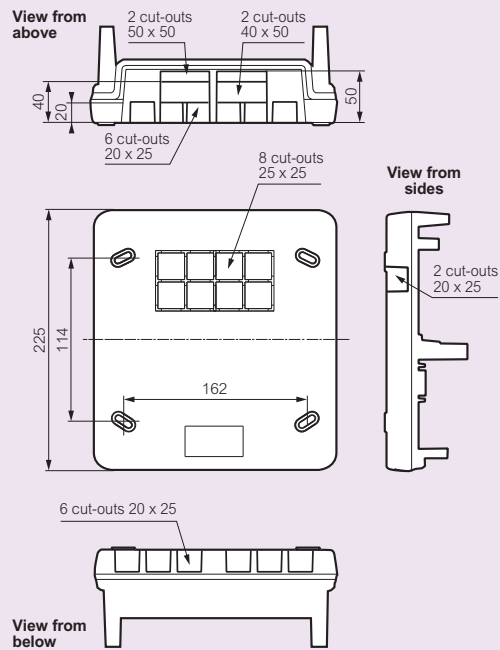

### 12 module unit

#### Back box fixing centres and cable entries (mm)

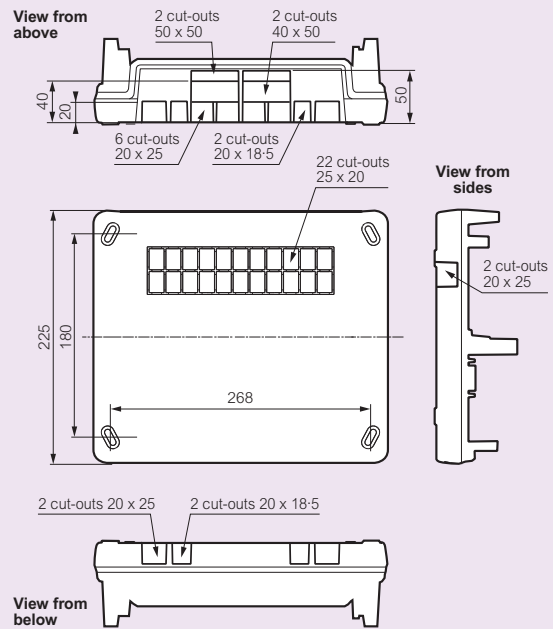

## insulated consumer units

### surface mounting (continued)

#### ■ 14/16 module unit

##### Back box fixing centres and cable entries (mm)

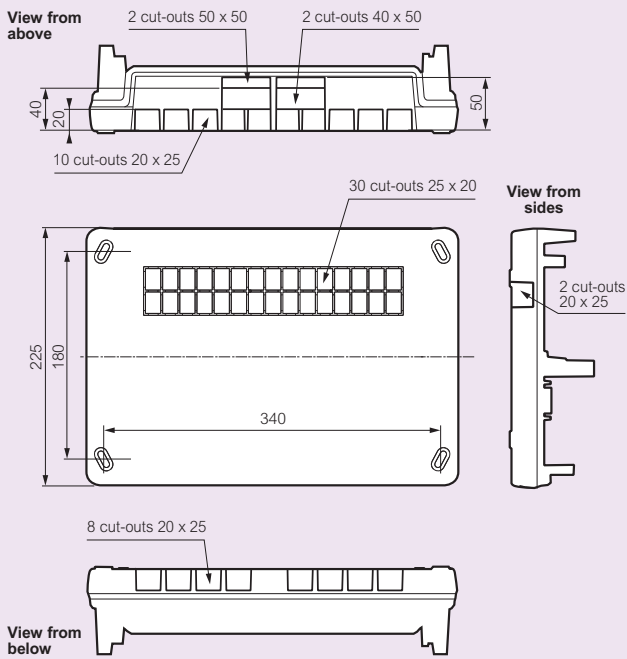

#### ■ 20/22 module unit

##### Back box fixing centres and cable entries (mm)

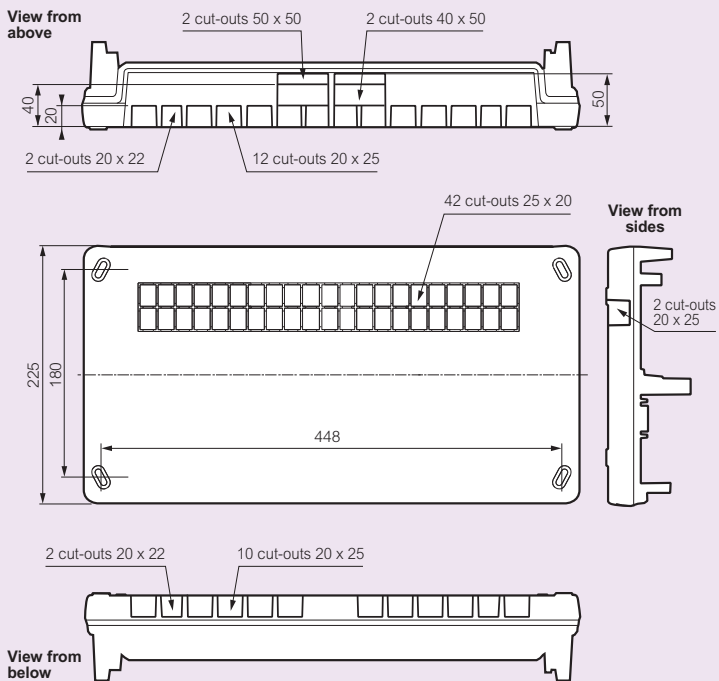

## metal consumer units

### surface mounting

#### ■ Metal - surface mounting dimensions (mm)

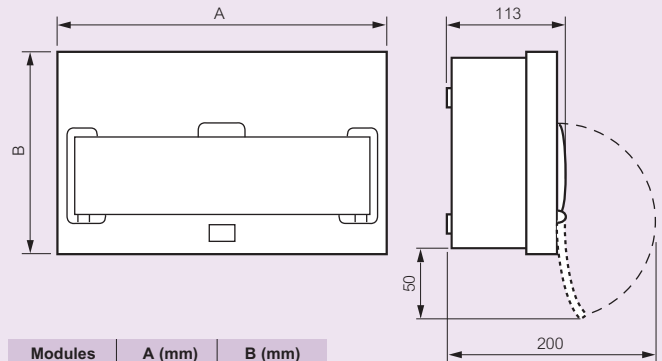

Modules	A (mm)	B (mm)
8	219	235
12	305	235
16	377	235
22	485	235

#### ■ 8 module unit

##### Back box fixing centres and cable entries (mm)

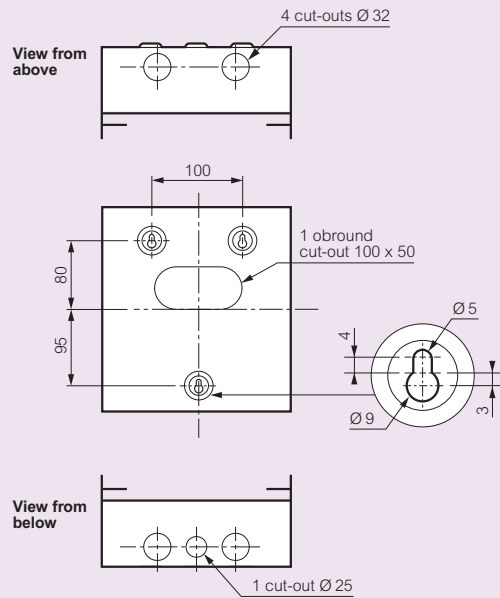

## metal consumer units surface mounting (continued)

### ■ 12 module unit

Back box fixing centres and cable entries (mm)

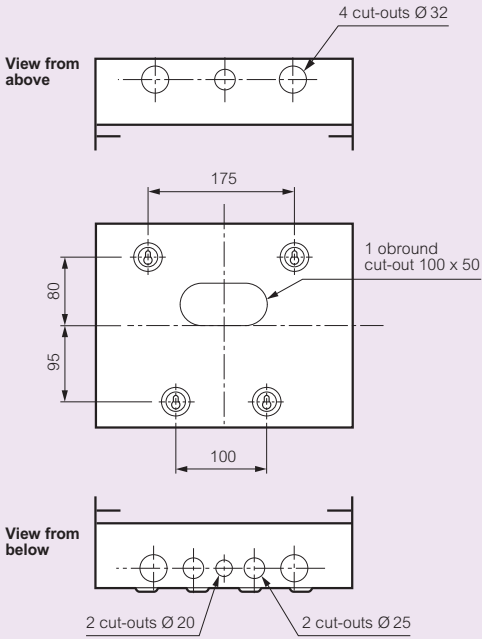

### ■ 16 module unit

Back box fixing centres and cable entries (mm)

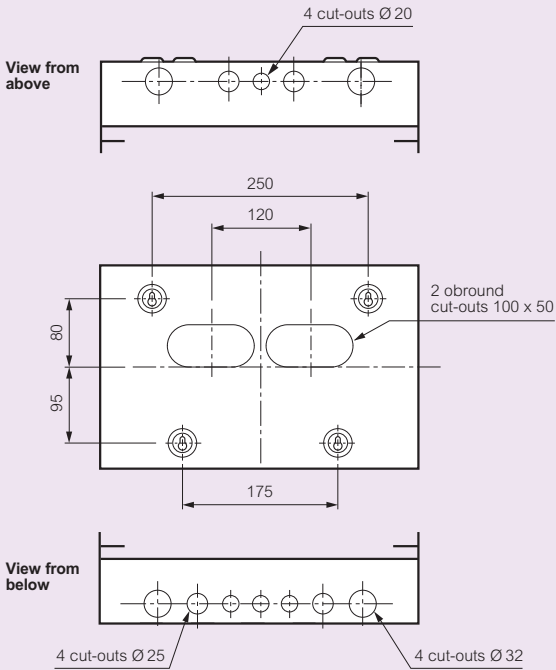

### ■ 22 module unit

Back box fixing centres and cable entries (mm)

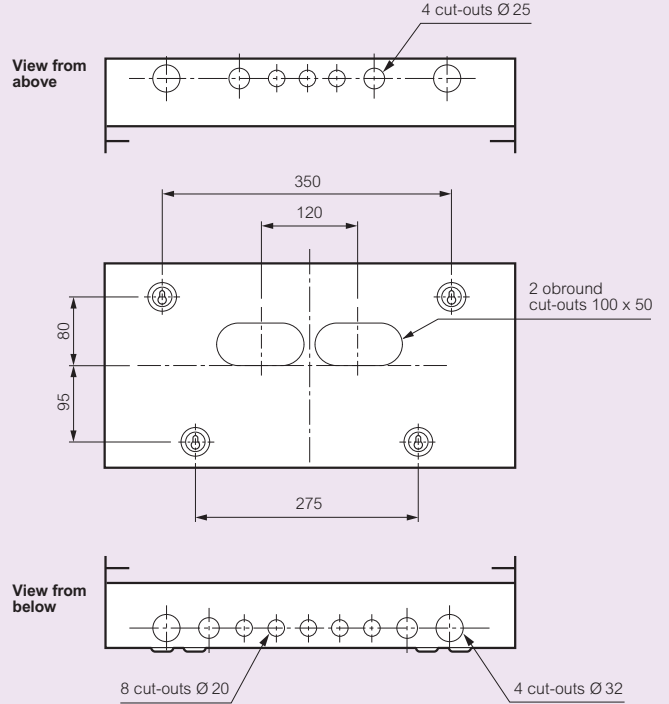

## voltage surge protectors

### ■ Protection against lightning effects

Lightning directly or indirectly generates the following effects :

- thermal (blow-outs, fire)
- electrodynamic (loosening of terminals)
- rise in earth voltage (risk of electrocution)
- overvoltages of several thousand volts and destructive induced currents (damage to electrical and electronic equipment, interruption of operation)

Protection against the effects of lightning is based essentially on :

- catching and discharging the current to earth
- the use of voltage surge protectors
- the passive protection of the installation

Passive protection designates the part of the protection provided by the structure and the configuration of the installation itself (neutral earthing system, area, level of equipotentiality, etc.)

### ■ Voltage surge protectors and regulation

Voltage surge protectors allow :

- protection of sensitive devices against direct and indirect effects of lightning
- limitation of harmful consequences to people or livestock
- continuity of work

#### 1 - Product standards EN 61643-11 and IEC 61643-1

Defines voltage surge protectors of two levels (types) :

	Type 1	Type 2	Type 3
Type of wave	10/350 $\mu$ s	8/20 $\mu$ s	1-2/50 $\mu$ s - 8/20 $\mu$ s
Main characteristics	$I_n$ , $I_{limp}$	$I_n$ , $I_{max}$	$U_{oc}$

#### 2 - Installation standards : IEC 60364 (or equivalent electric national standards)

The use of VSPs is recommended in new or renovated buildings in the following cases :

- buildings equipped with lightning conductors : type 1 VSPs with  $I_{limp} \geq 12.5$  kA

The use of VSPs is also strongly recommended in mountain areas, close to bodies of water or tall structures (buildings, trees, etc.), in the cases of line end installations or installations located less than 50 m from buildings equipped with lightning conductors

When VSPs are present on the power circuit, it is strongly advised to install a VSP on the communication circuits (telephone or data lines...)

### ■ Types of lightning strikes

Direct strike

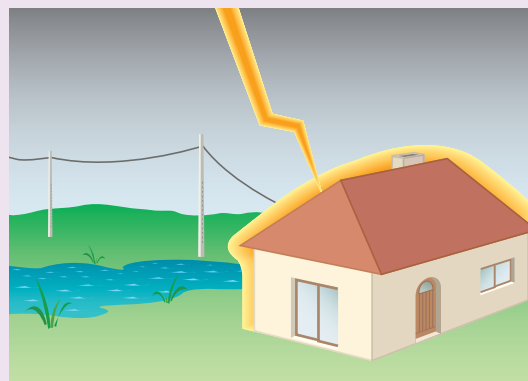

Overvoltages on power supply lines

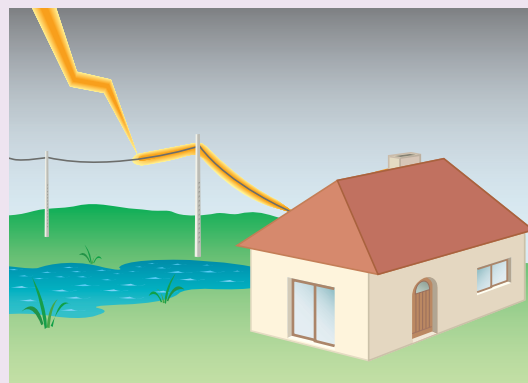

Overvoltages due to strikes in direct proximity of building

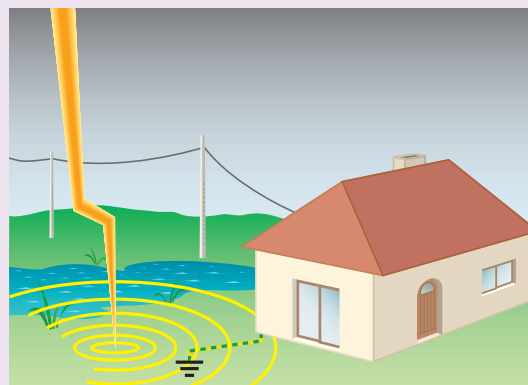



6019 74



6019 82



0019 66



0019 55



Technical information and dimensions p. 223

IP 65 - IK 09 - Class II

Self-extinguishing : resistance to incandescent wire 650 °C

Conform to EN 60439-3

Door and enclosure fully reversible

Removable chassis and faceplates from 2 row versions up

2 position rail for modular products and moulded cases

Spacing between rails 150 mm

Can be fitted with perforated plates and solid faceplates for mounting non-modular products

Lockable door handle, sealable cover and faceplate

Shock-resistant polystyrene material

Box colour light grey L750A, cover colour dark grey R746A

Supplied without terminal blocks

Pack	Cat. Nos.	Enclosures 2 to 8 modules	
		Number of rows	Number of modules
1	6019 32	1	2 (+1)
1	6019 74	1	4
1	6019 76	1	6
1	6019 78	1	8

Pack	Cat. Nos.	Enclosures 12 modules per row	
		Number of rows	Number of modules
1	6019 81	1	12
1	6019 82	2	24
1	6019 83	3	36

Pack	Cat. Nos.	Enclosures 18 modules per row	
		Number of rows	Number of modules
1	6019 85	1	18
1	6019 86	2	36
1	6019 87	3	54
1	6019 88	4	72

Pack	Cat. Nos.	Accessories	
1	0019 66	<b>Key lock</b>	N° 850
1	0019 68	<b>Sealing kit</b>	Set of 2 sealable terminal shields for cover and 8 sealable supports for faceplate
1	0019 69	<b>Wall mounting brackets</b>	Set of 4
20	0019 61	<b>Blanking plates</b>	5, separable into modules or 1/2 module Grey R746A
1	0019 55	<b>Direct piercing end caps</b>	Pack consisting of 2 Ø32 mm ISO end caps, 5 Ø25 mm ISO end caps and 10 Ø20 mm ISO end caps
2	0019 64	<b>Plain faceplates</b>	For 12 modules enclosures
2	0019 65		For 18 modules enclosures
1	0019 62	<b>Perforated plates</b>	Allow the DIN rail to be replaced with a Lina 25 plate <sup>1</sup> when integrating non-modular products
1	4018 53		For 12 modules enclosures Height 150 mm
1	4018 53		For 18 modules enclosures Height 150 mm
25	0980 03	<b>ISO M20 cable gland</b>	Cable gland IP 68



1 : For Lina 25 plates, see current Industrial and power protection catalogue



# Plexo<sup>3</sup> weatherproof enclosures and accessories

IP 65 - IK 09

## ■ Dimensions

### Enclosures 2, 4, 6 and 8 modules

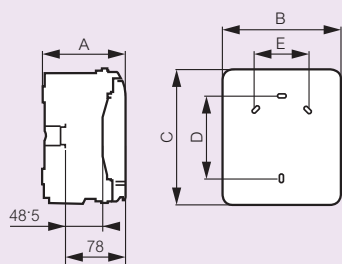

Cat. Nos.	Dimensions (mm)				
	A	B	C	D	E
6019 32	109	93	174	94	-
6019 74	115.6	128	200	120	-
6019 76	115.6	164	200	120	70
6019 78	115.6	200	200	120	106

### Enclosures 12 and 18 modules

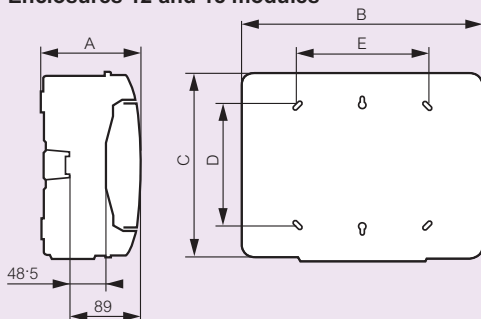

Cat. Nos.	Dimensions (mm)				
	A	B	C	D	E
6019 81	141	340	282	180	180
6019 82	161	340	432	330	180
6019 83	161	340	622	480	180
6019 85	141	448	282	180	288
6019 86	161	448	432	330	290
6019 87	161	448	622	480	290
6019 88	161	448	822	680	290

## ■ Fixing centres

### Fixing the enclosure on the wall

Each enclosure is equipped with knockout entries for 2 wall fixing methods :

#### Hanging fixing

1 point in the middle, 2 points at the bottom

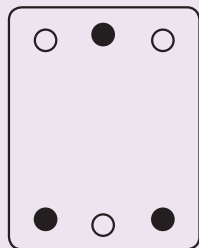

#### Adjustable peripheral fixing

4 fixing points

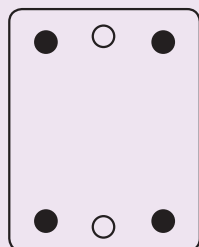

## ■ Number of knockouts on each side

Cat. Nos.	Top/bottom			Left/right		
	Ø20 mm	Ø25 mm	Ø32 mm	Ø20 mm	Ø25 mm	Ø32 mm
6019 32	2	-	-	-	-	-
6019 74	2	1	-	2	-	-
6019 76	4	1	-	2	-	-
6019 78	6	1	-	2	-	-
6019 81	7	2	2	-	-	2
6019 82	13	2	2	-	-	3
6019 83	13	2	2	-	-	4
6019 85	12	2	3	-	-	2
6019 86	13	4	3	-	-	3
6019 87	13	4	3	-	-	4
6019 88	13	4	3	-	-	5

## ■ Old/new range cross reference table

Old Plexo Cat. Nos.	New Plexo <sup>3</sup> Cat. Nos.	Number of rows	Total number of modules
<b>Enclosures 2 to 8 modules</b>			
0017 02	6019 32	1	2 (+1)
0017 04	6019 74	1	4
0017 06	6019 76	1	6
0017 08	6019 78	1	8
<b>Enclosures 12 modules per row</b>			
0017 11	6019 81	1	12
0017 12	6019 82	2	24
0017 13	6019 83	3	36
<b>Enclosures 18 modules per row</b>			
-	6019 85	1	18
-	6019 86	2	36
-	6019 87	3	54
-	6019 88	4	72

## ■ Direct piercing end caps

Cat. No.	Type	Number of end caps per pack	Ø	
			Min. (mm)	Max. (mm)
0019 55	ISO 20	10	4	13
	ISO 25	5	9	18
	ISO 32	2	12	25



# FAST, RELIABLE CONNECTIONS

For commercial and residential applications in both new and existing installations, Tenby Rapid Clamp Ultra creates earthing connections with a simple fixing method that makes fitting them in hard to reach areas easier than ever.

The unique 'twist' fixing method is up to 5 times faster when compared with traditional clamps.

So for mains incomer pipes, boiler replacement, special locations or supplementary bonding in pre-17th Edition installations, earthing is a whole lot easier with Tenby!

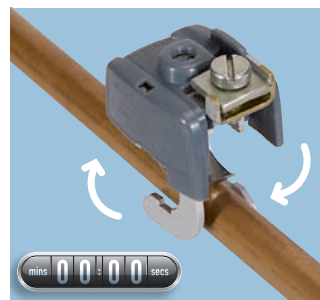

## Tenby® Rapid Clamp Ultra earth clamps



0343 85



0343 86



0343 87

Conform to BS 951 : 2009

Available in three sizes

Suitable for dry, non corrosive atmospheres and corrosive or humid conditions

Resistance of incandescent wire 960 °C

Resistivity of 0.4 mΩ

Colour : grey

Polyamide

Safe, intuitive 1/4 turn mounting ensuring an excellent, lasting equipotential link

Pack	Cat. Nos.	Earth clamps for all conditions			
		Pipe Ø		Connection cross-section	
		Ø min. (mm)	Ø max. (mm)	min. (mm <sup>2</sup> )	max. (mm <sup>2</sup> )
20	0343 85	12	16	2.5	16
10	0343 86	18	22	2.5	16
10	0343 87	28	32	2.5	16

## Tenby® Rapid Clamp earth clamps



EC14



EC15/2



EC16/3

Conform to BS 951 : 2009

Available in three types :

Red (EC14) for dry, non corrosive atmospheres

Blue (EC15) for corrosive or humid conditions

Green (EC16) for corrosive or humid conditions, large earth conductors

5 standard band lengths to suit pipe Ø of 12-32 mm, 32-50 mm, 50-75 mm, up to 100 mm and up to 150 mm

Pack	Cat. Nos.	Earth clamps for dry conditions
		Terminal size : A – D (2.5 – 10 mm <sup>2</sup> ) Maximum earth conductor 1 x 10 mm <sup>2</sup>
20	EC14	For pipe Ø 12 – 32 mm
20	EC14/2	For pipe Ø 32 – 50 mm
20	EC14/3	For pipe Ø 50 – 75 mm

Pack	Cat. Nos.	Earth clamps for all conditions
		Terminal size : A – D (2.5 – 10 mm <sup>2</sup> ) Maximum earth conductor 1 x 10 mm <sup>2</sup>
20	EC15	For pipe Ø 12 – 32 mm
20	EC15/2	For pipe Ø 32 – 50 mm
20	EC15/3	For pipe Ø 50 – 75 mm
20	EC15/4	For pipe Ø up to 100 mm
20	EC15/6	For pipe Ø up to 150 mm
		Terminal size : A – E (2.5 – 16 mm <sup>2</sup> ) Maximum earth conductor 2 x 16 mm <sup>2</sup>
20	EC16	For pipe Ø 12 – 32 mm
20	EC16/2	For pipe Ø 32 – 50 mm
20	EC16/3	For pipe Ø 50 – 75 mm

Cat. Nos.	Page No.	Cat. Nos.	Page No.	Cat. Nos.	Page No.	Cat. Nos.	Page No.	Cat. Nos.	Page No.	Cat. Nos.	Page No.	Cat. Nos.	Page No.	Cat. Nos.	Page No.
<b>1000</b>		0035 86	61	0089 10	216	0488 66	96	0611 30	204	0882 32	45	3331 64	18	3462 00	25
1200	197	89 62		11 -		68 83		49 -		33 88		65 -		30 -	
<b>7000</b>		98 64		12 -		72 54		0634 00	66	35 83		84 -		50 -	
7545	204	0036 52	54	15 -		73 87		31 -		91 47		85 -		60 -	
7768	-	53 -		16 -		74 83		32 -		0883 01	58	3332 05	18	3463 10	24
<b>0010 00</b>		56 -		17 -		75 -		33 -		05 46		84 -		3468 30	25
0013 31	217	58 84		18 -		84 97		34 -		20 -		85 -		33 -	
32	-	59 -		<b>0200 00</b>		0490 00	100	35 62		23 -		3336 14	18	41 -	
41	-	60 -		0261 45	25	04	-	38 66		27 47		15 -		50 -	
42	-	71 -		<b>0300 00</b>		0492 00	25	39 -		30 -		3337 14	21	51 -	
92	-	80 -		0327 80	126	01 -		41 -		31 48		15 -		70 -	
0016 64	215	0037 00	26	81 -		02 55		42 54		0891 09	167	24 18		90 -	
0019 55	222	21 203		0343 85	225	03 25		0675 18	58	10 -		25 -		3469 02	25
61	-	0038 41	54	86 -		04 -		0694 97	203	11 -		3338 14	18	03 -	
62	-	42 -		87 -		05 -		98 -		13 -		15 -		91 20	
64	-	0039 20	217	0380 23	31	06 -		0695 03	47	14 -		24 -		92 -	
65	-	<b>0040 00</b>		09 -		07 -		04 202		17 -		25 -		3474 00	25
66	-	0041 01	217	10 -		08 -		17 203		18 -		34 -		3482 00	22
68	-	07 -		11 55		09 -		18 -		40 -		35 -		01 -	
69	-	13 -		12 -		10 -		34 202		0892 79	61	44 -		02 -	
<b>0020 00</b>		47 216		13 -		11 55		35 -		0893 79	-	45 -		03 -	
0026 00	92	0043 31	-	14 -		12 -		47 -		0898 40	203	64 -		04 -	
01	-	36 -		15 -		13 -		48 -		0900 00		65 -		05 -	
02	54	0044 09	26	16 -		14 -		49 -		0980 03	201	3339 14	21	06 -	
04	92	40 215		17 -		15 -		80 203		2000 00		15 -		3484 02	22
11	54	41 -		18 25		16 -		83 -		2810 01	197	34 -	18	3491 40	22
12	92	42 -		19 55		17 -		85 -		03 -		35 -		3493 20	23
21	54	43 214		20 -		18 25		88 -		05 -		3368 13	24	21 -	
22	-	0048 80	93	21 -		19 55		89 -		08 -		3369 10	25	3494 10	25
31	-	81 -		22 -		20 -		90 -		41 -		82 24		3500 10	12
33	92	82 -		22 -		21 -		91 -		2819 08	197	3392 13	22	20 -	
34	96	0049 96	215	22 -		22 -		0696 51	203	3393 13	22	23 -		30 -	
35	-	<b>0060 00</b>		23 -		23 -		56 -		3421 70	19	3393 13	22	3501 10	14
45	93	0061 56	216	24 -		24 -		72 -		3422 00	20	3421 70	19	20 -	
<b>0030 00</b>		58 -		25 -		25 -		78 -		40 19		3422 00	20	30 -	
0035 12	97	60 -		26 87		26 87		81 -		3060 64	25	40 19		3502 11	12
16	-	61 -		27 81		27 81		0697 10	202	65 -		3423 50	20	12 -	
43	-	62 -		17 81		17 81		11 -		3080 11	21	3423 50	20	13 -	
44	-	63 -		20 82		20 82		15 -		12 -		3424 80	20	21 -	
47	-	64 -		21 -		21 -		16 -		13 -		3425 10	18	21 -	
51	55	65 -		22 -		22 -		17 -		14 -		50 19		22 -	
52	-	66 -		23 -		23 -		18 25		21 -		60 20		23 -	
53	54	0063 72	216	24 -		24 -		19 55		22 -		3426 00	19	31 -	
54	59	74 -		25 -		25 -		90 55		23 -		10 20		32 -	
55	-	76 -		26 87		26 87		91 97		24 -		30 -		33 -	
56	-	77 -		27 81		27 81		0495 94	26	24 -		40 -		3503 15	14
60	54	79 -		14 99		14 99		0497 50	26	25 -		40 -		25 -	
62	55	80 -		17 81		17 81		54 -		26 -		50 -		35	
64	64	81 -		20 82		20 82		0498 32	26	27 -		3429 71	22	3504 15	14
65	-	82 -		21 -		21 -		0499 83	26	28 -		72 -		25 -	
66	59	<b>0070 00</b>		22 -		22 -		<b>0500 00</b>		29 -		81 -		35	
67	54	0077 78	217	23 -		23 -		0516 93	70	30 -		82 -		35	
70	92	80 -		24 -		24 -		<b>0600 00</b>		31 50	32	91 -		3505 11	12
79	58	81 -		25 -		25 -		0600 81	205	3311 10	19	92 -		12 -	
80	-	82 -		26 87		26 87		85 -		20 -		3440 82	24	21 -	
82	61	<b>0080 00</b>		27 81		27 81		86 -		30 -		3441 82	23	22 -	
83	-	0077 78	217	28 82		28 82		87 -		3315 50	32	3442 02	24	23 -	
84	-	80 -		29 99		29 99		88 -		3326 50	19	12 -		31 -	
85	-	81 -		30 82		30 82		89 -		0811 77	159	3447 04	24	32 -	
		82 -		31 99		31 99		90 -		0818 52	158	3448 24	23	33 -	
		83 -		32 98		32 98		91 97		15 -		32 -		34	
		84 -		33 93		33 93		0495 94	26	3330 14	18	3460 00	25	41 -	
		85		34 55		34 55		0497 50	26	3331 04	18	20 -		42 -	
		<b>0080 00</b>		37 98		37 98		54 -		05 -		30 -		43 -	
		0086 29	217	38 82		38 82		0498 32	26	3315 50	32	44 -		61 -	
		30 -		39 99		39 99		0499 83	26	3326 50	19	45 -			
		0089 09	216	40 92		40 92		<b>0700 00</b>		3330 14	18				
				41 -		41 -		0767 11	122	3331 04	18				
				42 -		42 -		<b>0800 00</b>		05 -					
				43 -		43 -		0803 99	124	14 -					
				44 -		44 -		0811 77	159	15 -					
				45 -		45 -		0818 52	158	3330 14	18				
				46 -		46 -		53 195		3331 04	18				
				47 -		47 -		54 158		05 -					
				48 -		48 -		55 195		14 -					
				49 -		49 -		56 133		15 -					
				50 83		50 83		57 195		24 -					
				51 -		51 -		58 158		25 -					
				52 -		52 -		59 195		34 -					
				61 96		61 96		0882 23	99	35 -					
				62 -		62 -		30 83		44 -					
				64 -		64 -		31 -		45 -					

Cat. Nos.	Page No.	Cat. Nos.	Page No.	Cat. Nos.	Page No.	Cat. Nos.	Page No.	Cat. Nos.	Page No.	Cat. Nos.	Page No.	Cat. Nos.	Page No.										
3505	62	12	3511	42	13	3524	05	15	<b>5000 00</b>	5721	46	110	5723	06	128	5725	67	123	5727	84	129		
	63	-		43	-	3525	00	17			47	-		07	132		71	124		85	127		
	91	-		45	15		01	13			49	-		10	128		74	123		90	129		
	92	-		81	13		02	-			50	-		14	126		78	124		91	-		
	93	-		82	-		03	-			51	-		18	129		80	109		93	71		
3506	11	12		83	-		05	15			53	109		19	132		87	-		94	-		
	12	-		85	15	3527	00	17			57	110		20	-		94	126	5728	00	128		
	13	-	3512	00	16		01	13			58	130		21	110		96	-		01	-		
	15	14		01	13		02	-			63	128		22	128	5726	03	131		02	-		
	21	12		02	-		03	-			70	-		23	-		04	-		03	-		
	22	-		03	-		05	15			71	-		24	127		10	-		04	-		
	23	-		05	15	3530	00	17			72	-		31	128		11	-		05	129		
	25	14		11	13		01	13			73	-		33	-		13	-		06	128		
	31	12		12	-		02	-		5722	01	120		34	129		16	-		10	-		
	32	-		13	-		03	-			02	-		35	128		17	-		14	126		
	33	-		15	15		05	15			03	-		37	129		18	-		18	129		
	35	14		21	13	3532	00	17			07	123		38	-		19	-		22	128		
	41	12		22	-		01	13			08	-		41	132		30	-		23	-		
	42	-		23	-		02	-			10	115		42	-		32	-		24	127		
	43	-		25	15		03	-			11	-		60	130		33	-		31	128		
	45	14	3513	00	16		05	15			18	120		86	132		50	110		33	-		
	61	12		01	13	3533	00	17			19	-		90	133		51	-		34	129		
	62	-		02	-		01	13			20	120		92	-		53	109		35	128		
	63	-		03	-		02	-			21	119		96	-		57	110		37	129		
	65	14		05	15		03	-			22	-	5724	53	119		58	130		38	-		
	91	12		11	13		05	15			23	-		54	-		63	128		41	132		
	92	-		12	-	3540	00	13			24	123		55	-		70	-		42	-		
	93	-		13	13	3632	11	32			25	-		56	-		71	-		86	-		
	95	14		15	15		21	-			26	119		67	131		72	-	5730	00	113		
3510	00	16		21	13	3638	11	32			27	-		74	127		73	-		01	-		
	01	13		22	-	3654	11	32			30	122		76	-	5727	01	120		02	-		
	02	-		23	-		21	-			31	-		88	124		02	-		23	112		
	03	-		25	15	3675	11	32			32	119	5725	01	113		03	-		24	-		
	05	15	3520	00	16		21	-			33	-		02	-		07	123		25	-		
	11	13		31	13	3681	11	32			38	123		05	111		10	115		26	-		
	12	-		32	-		21	-			48	123		06	-		11	-		27	-		
	13	-		33	-	3689	11	32			53	122		08	-		18	120		28	-		
	15	15		35	15		21	-			59	-		10	-		19	-		29	108		
	21	13		41	13	3749	00	66			63	120		11	-		20	-		30	112		
	22	-		42	-		71	124			70	129		12	108		23	123		31	-		
	23	-		43	-	<b>4000 00</b>					71	126		13	111		24	-		51	113		
	25	15		45	15	4018	53	222			72	-		14	-		25	-		61	112		
	41	13	3521	00	16	4022	70	216			73	-		21	131		26	119		63	-		
	42	-		61	13		71	-			74	-		31	113		27	-		64	108		
	43	-		62	-		72	-			75	-		35	111		30	122		71	112		
	45	15		63	-		73	-			76	126		36	-		31	-		72	-		
	81	13		65	15		74	-	5721	03	131		37	-		32	119		32	119		73	-
	82	-		81	13		75	-			04	-		38	-		33	-		74	108		
	83	-		82	-		76	-			10	-		39	108		53	122		75	112		
	85	15		83	-		77	-			11	-		40	111		59	-		76	-		
3511	00	16		85	15		78	-			13	-		42	-		63	120		78	-		
	01	13	3522	00	17	4023	10	216			15	-		43	-		70	129		80	113		
	02	-		01	13		11	-			16	-		44	-		71	126		93	108		
	03	-		02	-		13	-			17	-		45	108		72	-	5731	00	113		
	05	15		03	-		14	-			18	-		46	111		73	-		01	-		
	11	13		05	15		15	-			19	-		47	-		74	-		02	-		
	12	-	3523	01	13		16	-			30	-		48	-		75	-		23	112		
	13	-		02	-		17	-			32	-		49	-		76	-		24	-		
	15	15		03	-		18	-			33	-		51	114		77	129		25	-		
	21	13		05	15		19	-			40	110		54	123		79	126		26	-		
	22	-	3524	00	16		20	-			41	-		56	113		80	129		27	-		
	23	-		01	13	4130	90	216			43	-		57	123		81	126		28	-		
	25	15		02	-		91	-			44	-		58	108		82	-		29	108		
	41	13		03	-		93	-			45	-		61	-		83	129		30	112		

Cat. Nos.	Page No.	Cat. Nos.	Page No.	Cat. Nos.	Page No.	Cat. Nos.	Page No.	Cat. Nos.	Page No.	Cat. Nos.	Page No.	Cat. Nos.	Page No.	Cat. Nos.	Page No.
5731 31	112	5737 72	127	5739 02	52	5740 13	130	5743 55	115	5751 03	142	5755 53	142	5761 36	143
51	113	73	-	03	-	14	-	56	-	04	-	54	-	37	147
61	112	74	-	04	-	15	-	57	-	05	145	55	145	38	140
63	-	84	121	05	-	31	81	58	-	06	144	56	144	39	145
64	108	85	-	08	-	32	67	59	-	20	138	60	138	40	144
71	112	86	-	09	-	33	-	60	53	21	139	61	139	41	141
72	-	87	-	12	-	34	80	61	-	22	-	62	-	42	-
73	-	90	46	13	-	35	130	62	-	23	142	63	142	43	146
74	108	91	-	18	58	36	-	63	-	24	-	64	-	44	-
75	112	94	121	19	-	38	66	65	-	25	145	65	145	45	143
76	-	95	-	20	-	39	26	67	-	26	144	66	144	46	-
78	-	97	-	21	-	43	-	68	-	30	110	5756 10	138	47	147
80	113	5738 12	44	22	-	44	62	69	-	31	-	11	139	48	140
93	108	13	-	23	-	46	87	70	-	32	-	12	-	49	145
5732 19	120	14	-	24	-	47	80	71	-	40	-	13	142	50	144
20	-	15	-	25	-	48	87	76	-	41	-	14	-	51	141
22	121	16	-	26	61	49	81	77	-	42	-	15	145	52	-
23	-	17	-	27	-	50	114	78	-	50	138	16	144	53	146
24	-	18	-	28	-	51	-	79	-	60	-	90	138	54	-
25	-	19	-	29	-	52	-	82	-	61	139	91	139	55	143
34	-	20	-	32	62	53	-	83	-	62	-	92	-	56	-
35	-	21	-	33	-	54	-	84	-	63	142	5760 00	133	57	147
36	-	22	-	50	23	56	115	85	-	64	-	01	-	58	140
37	-	23	-	51	-	57	-	86	-	65	145	02	-	59	145
72	127	24	-	52	65	58	-	87	-	66	144	03	-	60	144
73	-	25	-	53	-	60	116	90	-	90	133	13	-	61	141
74	-	26	-	58	64	61	118	91	-	5752 00	138	15	-	62	-
84	121	27	-	61	52	62	-	92	-	01	139	16	-	63	146
86	-	28	-	62	23	63	130	93	-	02	-	5761 00	144	64	-
87	-	29	-	63	-	64	-	5744 01	126	03	142	01	141	65	143
94	-	32	-	64	53	65	-	51	-	04	-	02	-	66	-
95	-	33	-	65	-	81	81	5745 01	127	05	145	03	146	67	147
97	-	34	45	66	61	82	119	51	-	06	144	04	-	68	140
5733 74	127	35	-	67	-	84	-	87	122	10	138	05	143	69	145
82	121	36	-	70	53	85	130	88	-	11	139	06	-	70	144
83	-	37	-	71	-	86	-	89	-	12	-	07	147	71	141
84	-	38	-	72	-	87	122	90	-	13	142	08	140	72	-
85	-	39	-	73	-	88	-	91	-	14	-	09	145	73	146
98	124	40	44	74	52	89	-	92	-	15	145	10	144	74	-
5734 55	114	41	-	75	-	90	-	93	-	16	144	11	141	75	143
5735 96	127	42	45	76	61	91	-	5750 70	138	5753 70	138	12	-	76	-
5736 55	114	43	-	77	-	92	-	71	139	71	139	13	146	77	147
5737 16	52	46	48	78	-	93	-	72	-	72	-	14	-	78	140
17	-	47	-	81	-	94	80	73	142	73	142	15	143	79	145
19	120	48	45	82	-	96	87	74	-	74	-	16	-	80	144
20	-	49	-	83	-	97	80	75	145	75	145	17	147	81	141
22	121	56	48	86	65	98	87	76	144	76	144	18	140	82	-
23	-	57	-	87	52	99	81	80	138	90	138	19	145	83	146
24	-	58	47	88	62	5743 00	114	81	139	91	139	20	144	84	-
25	-	60	-	93	64	01	-	82	-	92	-	21	141	85	143
34	-	62	46	94	-	02	-	83	142	5754 00	138	22	-	86	-
35	-	64	-	96	54	03	-	84	-	01	139	23	146	87	147
36	-	66	-	98	25	04	-	85	145	02	-	24	-	88	140
37	-	70	45	99	-	05	115	86	144	52	119	25	143	89	145
50	46	72	47	5740 00	114	06	-	90	138	5755 40	138	26	-	90	144
51	-	73	-	01	-	07	-	91	139	41	139	27	147	91	141
54	-	74	-	02	-	08	-	92	-	42	-	28	140	92	-
55	-	75	-	03	-	09	-	93	142	43	142	29	145	93	146
58	-	82	121	04	-	11	24	94	-	44	-	30	144	94	-
59	-	83	-	06	115	50	114	95	145	45	145	31	141	95	143
64	-	84	-	07	-	51	-	96	144	46	144	32	-	96	-
65	-	85	-	08	-	52	-	5751 00	138	50	138	33	146	97	147
68	-	5739 00	52	10	116	53	-	01	139	51	139	34	-	98	140
69	-	01	-	11	24	54	-	02	-	52	-	35	143	99	145

Cat. Nos.	Page No.	Cat. Nos.	Page No.	Cat. Nos.	Page No.	Cat. Nos.	Page No.	Cat. Nos.	Page No.	Cat. Nos.	Page No.	Cat. Nos.	Page No.	Cat. Nos.	Page No.
5762 00	144	5767 04	142	6075 02	214	6915 09	206	7300 35CH	169	7301 14	164	7310 47	170	7312 32	172
01	141	05	145	10	-	<b>7000 00</b>		7300 35DW	-	16	-	50	174	33	-
02	-	06	144	11	-	7300 00	159	7300 35EH	-	20	-	51	-	34	-
03	146	10	-	12	-	01	-	7300 35EX	-	22	-	52	175	35	-
04	-	13	146	14	-	02	-	7300 35FF	-	30	159	54	174	36	-
05	143	14	-	16	-	03	-	7300 35FN	-	31	-	56	-	37	-
06	-	15	143	19	215	04	-	7300 35FR	-	32	-	57	-	40	174
07	147	16	-	21	214	05	-	7300 35HB	-	33	-	59	171	41	-
08	140	17	147	22	-	06	-	7300 35HR	-	36	163	60	-	42	-
09	145	18	140	39	215	07	-	7300 35MW	-	40	165	61	-	43	-
10	144	19	145	49	-	08	-	7300 35OV	-	53	166	65	-	45	-
11	141	40	138	54	214	09	-	7300 35TD	-	56	160	68	-	46	170
12	-	41	139	56	-	10	-	7300 35TR	-	57	-	69	-	47	-
13	146	42	-	74	-	10	164	7300 35WM	-	58	166	70	-	50	174
14	-	43	142	76	-	7300 10CG	169	7300 36	163	61	161	71	-	51	-
15	143	44	-	89	215	7300 10CH	-	37	-	62	-	75	-	52	175
16	-	45	145	99	-	7300 10DW	-	40	165	80	194	88	-	54	174
17	147	46	144	6338 01	70	7300 10EH	-	41	-	81	-	89	-	56	-
18	140	50	-	02	-	7300 10EX	-	42	-	82	195	90	-	57	-
19	145	51	141	21	-	7300 10FF	-	43	-	83	-	91	175	59	171
5763 70	144	52	-	22	-	7300 10FN	-	45	-	84	-	92	-	60	-
73	146	53	146	23	-	7300 10FR	-	46	160	85	-	93	-	61	-
74	-	54	-	25	-	7300 10HB	-	47	-	86	-	94	-	65	-
75	143	55	143	26	-	7300 10HR	-	48	-	87	-	95	-	68	-
76	-	56	-	27	-	7300 10MW	-	49	-	88	158	96	-	69	-
77	147	57	147	28	-	7300 10OV	-	50	165	90	-	97	171	70	-
78	140	58	140	29	-	7300 10TD	-	51	-	91	166	98	-	71	-
79	145	59	145	30	-	7300 10TR	-	52	166	92	-	7311 31	170	75	-
5764 80	23	<b>6000 00</b>		32	71	7300 10WM	-	53	-	93	-	32	-	88	-
83	-	6010 60	217	33	70	7300 11	159	54	165	94	-	33	-	89	-
84	-	61	-	40	71	12	164	56	-	95	-	56	-	90	-
86	-	62	-	41	-	14	-	57	-	96	-	57	-	91	175
87	-	63	-	43	-	16	-	58	166	7310 00	170	82	195	92	-
5765 10	23	6019 32	222	44	-	18	-	59	162	01	-	83	-	93	-
13	-	74	-	45	-	19	-	60	161	02	-	84	-	94	-
14	-	76	-	46	-	20	-	61	-	03	-	85	-	95	-
16	-	78	-	47	-	21	-	64	-	04	-	86	-	96	-
17	-	81	-	48	70	22	-	65	-	05	-	87	-	97	171
20	144	82	-	50	71	23	-	66	-	07	-	88	158	98	-
23	142	83	-	53	70	26	-	67	-	09	-	90	-	7313 31	170
24	-	85	-	64	71	28	-	68	162	10	173	91	175	32	-
26	144	86	-	65	-	29	-	69	-	12	-	92	-	33	-
37	147	87	-	66	-	30	163	70	161	14	-	93	-	56	-
5766 80	138	88	-	68	-	31	-	71	-	16	-	94	-	57	-
81	139	89	-	72	-	32	-	74	-	19	-	7312 00	170	82	195
82	-	6027 10	216	73	-	33	-	75	-	21	-	01	-	83	-
83	142	11	-	6339 91	71	34	-	76	-	22	-	02	-	84	-
84	-	6064 16	216	92	-	7300 34CG	169	77	-	23	-	03	-	85	-
85	145	17	-	93	70	7300 34CH	-	87	162	26	-	04	-	86	-
86	144	18	-	6603 07	205	7300 34DW	-	88	-	29	-	05	-	87	-
90	-	19	-	6604 17	207	7300 34EH	-	89	-	30	172	07	-	88	158
91	141	20	-	18	-	7300 34EX	-	90	-	31	-	09	-	90	-
92	-	21	-	6745 32	161	7300 34FF	-	91	166	32	-	10	173	91	175
93	146	28	-	6846 03	201	7300 34FN	-	92	-	33	-	12	-	92	-
94	-	6065 01	215	04	-	7300 34FR	-	93	-	34	-	14	-	93	-
95	143	02	-	19	-	7300 34HB	-	94	-	35	-	16	-	94	-
96	-	04	-	29	-	7300 34HR	-	95	-	36	-	19	-	7330 00	176
97	147	06	-	36	-	7300 34MW	-	96	-	37	-	21	-	01	-
98	140	11	-	38	-	7300 34OV	-	97	162	40	174	22	-	02	-
99	145	12	-	45	-	7300 34TD	-	98	-	41	-	23	-	03	-
5767 00	138	54	-	6890 27	133	7300 34TR	-	99	166	42	-	26	-	04	-
01	139	56	-	28	-	7300 34WM	-	7301 00	166	43	-	29	-	05	-
02	-	6075 00	214	38	-	7300 35	163	10	164	45	-	30	172	06	-
03	142	01	-	6915 06	206	7300 35CG	169	12	-	46	170	31	-	07	-

Cat. Nos.	Page No.	Cat. Nos.	Page No.	Cat. Nos.	Page No.	Cat. Nos.	Page No.	Cat. Nos.	Page No.	Cat. Nos.	Page No.	Cat. Nos.	Page No.	Cat. Nos.	Page No.
7330 09	176	7331 85	195	7332 91	181	7338 93	186	7354 20TD	192	7355 07	190	7355 21HR	192	8206 48	31
10	179	86	-	92	-	94	-	7354 20TR	-	7355 07MN	192	7355 21LG	-	50	-
12	-	87	-	93	-	95	185	7354 20WD	-	7355 07MS	-	7355 21MW	-	8210 79	31
14	-	88	158	94	-	96	-	7354 20WH	-	7355 10	190	7355 21OV	-	82	30
16	-	90	-	95	-	97	183	7354 20WM	-	7355 10MN	192	7355 21PH	-	83	-
19	-	91	181	96	-	98	-	7354 21	190	7355 10MS	-	7355 21TD	-	84	-
20	-	92	-	97	177	7339 82	195	7354 21BL	192	7355 11	190	7355 21TR	-	85	-
21	-	93	-	98	-	83	-	7354 21CH	-	7355 12	-	7355 21WD	-	86	-
22	-	94	-	7333 31	176	84	-	7354 21DW	-	7355 12MN	192	7355 21WH	-	87	-
23	-	7332 00	176	32	-	85	-	7354 21EF	-	7355 12MS	-	7355 21WM	-	8216 30	30
26	-	01	-	33	-	86	-	7354 21EH	-	7355 13	190	7355 22	190	31	-
28	-	02	-	56	-	87	-	7354 21EX	-	7355 13MN	192	7355 22MN	192	32	31
29	-	03	-	57	-	88	158	7354 21FF	-	7355 13MS	-	7355 22MS	-	33	-
30	178	04	-	80	194	90	-	7354 21FN	-	7355 14	190	7355 23	190	34	-
31	-	05	-	81	-	91	186	7354 21FR	-	7355 14AR	-	7355 23ET	-	35	-
32	-	06	-	82	195	92	-	7354 21FZ	-	7355 14MN	192	7355 24	-	8218 46	166
33	-	07	-	83	-	93	-	7354 21HB	-	7355 14MS	-	25	-	47	-
34	-	09	-	84	-	94	-	7354 21HD	-	7355 15	190	35	191	57	214
35	-	10	179	85	-	7350 30	191	7354 21HR	-	7355 15MN	192	36	-	58	-
36	-	12	-	86	-	60	-	7354 21LG	-	7355 15MS	-	40	-		
37	-	14	-	87	-	62	-	7354 21MW	-	7355 16	190	41	-		
40	180	16	-	88	158	7351 30	191	7354 21OV	-	7355 17	-	46	-		
41	-	19	-	90	-	60	-	7354 21PH	-	7355 18	190	47	-	AP13-WH	199
42	-	20	-	91	181	62	-	7354 21TD	-	7355 18MN	192	48	-	AZ0010	-
43	-	21	-	92	-	7352 56	191	7354 21TR	-	7355 18MS	-	50	-	AZ0050	-
45	-	22	-	93	-	65	-	7354 21WD	-	7355 19	190	51	-		
46	176	23	-	94	-	7353 56	191	7354 21WH	-	7355 20	-	7364 00	187		
47	-	26	-	7338 00	183	65	-	7354 21WM	-	7355 20BL	192	01	-		
50	180	28	-	01	-	7354 00	190	7354 22	190	7355 20CH	-	03	167		
51	-	29	-	02	-	01	-	23	-	7355 20DW	-	04	-		
52	181	30	178	03	-	03	-	7354 23ET	190	7355 20EF	-	05	-	EC14	225
54	180	31	-	05	-	05	-	7354 24	-	7355 20EH	-	06	-	EC14/2	-
56	-	32	-	10	184	7354 05PE	190	25	-	7355 20EX	-	07	-	EC14/3	-
59	177	33	-	12	-	06	-	35	191	7355 20FF	-	10	-	EC15	-
60	-	34	-	14	-	07	-	36	-	7355 20FN	-	11	-	EC15/2	-
61	-	35	-	16	-	10	-	40	-	7355 20FR	-	13	-	EC15/4	-
65	-	36	-	19	-	11	-	41	-	7355 20FZ	-	18	187	EC15/6	-
68	178	37	-	20	-	12	-	46	-	7355 20HB	-	20	-	EC16	-
69	-	40	180	21	-	13	-	47	-	7355 20HD	-	21	-	EC16/2	-
70	177	41	-	30	-	14	-	48	-	7355 20HR	-	22	-	EC16/3	-
71	-	42	-	31	-	7354 14AR	190	50	-	7355 20LG	-	28	-	EP13 Red	199
74	-	43	-	32	-	15	-	51	-	7355 20MN	-	32	-	EP2000	-
75	-	45	-	33	-	16	-	74	158	7355 20MS	-	40	167	ES6000	-
88	-	46	176	34	-	17	-	76	-	7355 20MW	-	41	-	ES6005	-
89	-	47	-	35	-	18	-	81	175	7355 20OV	-				
90	178	50	180	36	-	19	-	82	-	7355 20PH	-	<b>8000 00</b>			
91	181	51	-	37	-	20	-	90	166	7355 20TD	-	8200 21	39		
92	-	52	181	40	185	7354 20BL	192	91	166	7355 20TR	-	71	177	F442	25
93	-	54	180	41	-	7354 20CH	-	92	-	7355 20WD	-	72	-		
94	-	56	-	50	-	7354 20DW	-	93	195	7355 20WH	-	74	161		
95	-	57	-	51	-	7354 20EF	-	95	194	7355 20WM	-	8201 42	165	UPS200	199
96	-	59	177	56	-	7354 20EH	-	96	-	7355 21	190	43	180	UPS600	199
97	177	60	-	57	-	7354 20EX	-	7355 00	190	7355 21BL	192	44	-	UPS615	199
98	-	61	-	60	183	7354 20FF	-	7355 00MN	192	7355 21CH	-	45	174		
7331 31	176	65	-	61	-	7354 20FN	-	7355 00MS	-	7355 21DW	-	46	-		
32	-	68	178	65	-	7354 20FR	-	7355 01	190	7355 21EF	-	8204 07	215		
33	-	69	-	70	-	7354 20FZ	-	7355 03	-	7355 21EH	-	50	182		
56	-	70	177	71	-	7354 20HB	-	7355 03MN	192	7355 21EX	-	51	-		
57	-	71	-	73	-	7354 20HD	-	7355 03MS	-	7355 21FF	-	52	-		
80	194	74	-	75	-	7354 20HR	-	7355 05	190	7355 21FN	-	53	-		
81	-	75	-	88	-	7354 20LG	-	7355 05MN	192	7355 21FR	-	58	165		
82	195	88	-	89	-	7354 20MW	-	7355 05MS	-	7355 21FZ	-	60	204		
83	-	89	-	91	186	7354 20OV	-	7355 05PE	190	7355 21HB	-	69	-		
84	-	90	178	92	-	7354 20PH	-	7355 06	-	7355 21HD	-	90	205		



# Obsolete items cross-reference tables

## Bticino

Bticino Sfera phased out items			Bticino NEW Sfera closest equivalent replacement		
Cat. Nos.	Description	Status	Cat. Nos.	Description	Page No.
3311 10	1 module flush mounting box	P	3500 10	1 module flush mounting box	12
3311 20	2 module flush mounting box	P	3500 20	2 module flush mounting box	12
3311 30	3 module flush mounting box	P	3500 30	3 module flush mounting box	12
3312 11	1 module surround plate	P	3502 11	1 module surround plate	12
3312 21	2 module surround plate	P	3502 21	2 module surround plate	12
3312 31	3 module surround plate	P	3502 31	3 module surround plate	12
3314 11	1 module rainshield	P	3505 11	1 module rainshield	12
3314 21	2 module rainshield	P	3505 21	2 module rainshield	12
3314 31	3 module rainshield	P	3505 31	3 module rainshield	12
3314 41	4 module rainshield	P	3505 41	4 module rainshield	12
3314 61	6 module rainshield	P	3505 61	6 module rainshield	12
3314 91	9 module rainshield	P	3505 91	9 module rainshield	12
3313 11	1 module surface mounting box	P	3506 11	1 module surface mounting box	12
3313 21	2 module surface mounting box	P	3506 21	2 module surface mounting box	12
3313 31	3 module surface mounting box	P	3506 31	3 module surface mounting box	12
3313 41	4 module surface mounting box	P	3506 41	4 module surface mounting box	12
3313 61	6 module surface mounting box	P	3506 61	6 module surface mounting box	12
3313 91	9 module surface mounting box	P	3506 91	9 module surface mounting box	12
3421 50	Basic speaker module	P	3510 00	Basic speaker module	13
3321 01	Basic speaker module - front cover	P	3510 01	Basic speaker module - front cover	13
3321 11	Basic speaker module 1 push button - front cover	P	3510 11	Basic speaker module 1 push button - front cover	13
3321 21	Basic speaker module 2 push buttons - front cover	P	3510 21	Basic speaker module 2 push buttons - front cover	13
3423 50	Speaker module	P	3511 00	Speaker module	13
3421 70	Speaker module	P	3511 00	Speaker module	13
3321 01	Speaker module - front cover	P	3511 01	Speaker module - front cover	13
3321 11	Speaker module - front cover	P	3511 01	Speaker module - front cover	13
3321 21	Speaker module - front cover	P	3511 01	Speaker module front cover	13
3321 01	Speaker module - front cover	P	3511 21	Speaker module 2 push buttons - front cover	13
3321 11	Speaker module - front cover	P	3511 41	Speaker module 2 push buttons / double row - front cover	13
3321 21	Speaker module - front cover	P	3511 41	Speaker module 2 push buttons / double row - front cover	13
3323 21	Speaker module - front cover	P	3511 81	Speaker module 4 push buttons / double row - front cover	13
3323 41	Speaker module - front cover	P	3511 81	Speaker module 4 push buttons / double row - front cover	13
3422 40	4 push buttons module	P	3520 00	4 push buttons / single row module	13
3322 31	3 push buttons - front cover	P	3520 31	3 push buttons - front cover	13
3322 41	4 push buttons - front cover	P	3520 41	4 push buttons - front cover	13
3424 80	8 push buttons module	P	3521 00	8 push buttons / double row module	13
3424 61	6 push buttons 2 columns - front cover	P	3521 61	6 push buttons double row - front cover	13
3424 81	8 push buttons 2 columns - front cover	P	3521 81	8 push buttons double row - front cover	13
3425 60	Audio / video camera module	P	3512 00	Camera - audio / video module	13
3424 61	Audio / video camera module - front cover	P	3512 01	Camera - audio / video module - front cover	13
3424 71	Audio / video camera module 1 push button - front cover	P	3512 11	Camera - audio / video module 1 push button - front cover	13
3424 81	Audio / video camera module 2 push buttons - front cover	P	3512 21	Camera - audio / video module 2 push buttons / double row - front cover	13
3425 10	Black and white camera module	P	3524 00	Camera - night / day with wide angle module	13
3425 50	Colour camera module	P	3524 00	Camera - night / day with wide angle module	13
3422 00	Name plate module	P	3522 00	Name plate module	13
3322 01	Name plate module - front cover	P	3522 01	Name plate module - front cover	13
3426 30	Speaker module with graphic display	P	3525 00 + 351100	Graphic display module + speaker module	13
3326 61	Speaker and scrolling function - front cover	P	3525 01	Graphic display module - front cover	13
3426 00	Alphanumeric call display module	P	3525 00 + 353000	Graphic display module + keypad module	13
3426 40	Extra alphanumeric call display module	P	3525 00 + 353000	Graphic display module + keypad module	13
3426 10	Numeric digital keypad module	P	3525 00 + 353000	Graphic display module + keypad module	13
3326 50	Code lock module	P	3530 00	Keypad module	13
3326 51	Code lock module - front cover	P	3530 01	Keypad module - front cover	13
3329 11	Blanking plate	P	3523 01	Blanking module	13

## Arteor

Arteor phased out items			Arteor closest equivalent replacement		
Cat. Nos.	Description	Status	Cat. Nos.	Description	Page No.
5739 16	1-2" touch screen (white)	P	5737 16	1-2" touch screen (white)	64
5739 17	1-2" touch screen (magnesium)	P	5737 17	1-2" touch screen (magnesium)	64
5739 60	3-5" touch screen (magnesium)	P	5739 58	3-5" touch screen (magnesium)	64

Status  
P = phase out

## Protection classifications

### Protection against solid bodies and liquids : Index of protection - IP xx

Degree of protection of enclosures of electrical equipment in accordance with standards IEC 60529, BS EN 60529  
Up to 1 000 V<sub>~</sub> and 1 500 V<sub>==</sub>

1st digit: protection against solid bodies			Additional letter IP XX (ABCD): protection against direct contact resulting from the access to hazardous current-carrying parts			2nd digit: protection against liquids		
IP	tests		IP	tests	protection	IP	tests	
0		No protection				0		No protection
1		Protected against solid bodies larger than 50 mm	A		The back of the hand remains remote from dangerous parts	1		Protected against vertically-falling drops of water (condensation)
2		Protected against solid bodies larger than 12.5 mm	B		The dangerous parts can not be touched when introducing a finger	2		Protected against drops of water falling at up to 15° from the vertical
3		Protected against solid bodies larger than 2.5 mm	C		The dangerous parts can not be touched when introducing a tool (eg a screwdriver)	3		Protected against drops of rain water at up to 60° from the vertical
4		Protected against solid bodies larger than 1 mm	D		The dangerous parts can not be touched when introducing a wire	4		Protected against projections of water from all directions
5		Protected against dust (no harmful deposit)				5		Protected against jets of water from all directions
6		Completely protected against dust				6		Protected against jets of water of similar force to heavy seas
						7		Protected against the effects of immersion
						8		Protected against prolonged effects of immersion under pressure

### Protection against mechanical impact : Index of protection - IK

According to standards IEC 62262 and BS EN 62262

IK	Tests	Impact energy (in Joules)
IK 00		0
IK 01		0.15
IK 02		0.2
IK 03		0.35
IK 04		0.5
IK 05		0.7
IK 06		1
IK 07		2
IK 08		5
IK 09		10
IK 10		20

(1) A product previously classed as IP xx-7 can be assumed to fulfill the conditions of an IP xx - IK 08

This table can be used to ascertain the resistance of a product to an impact given in Joules from the IK code (graduated from 00 to 10). It can also be used to ascertain the correspondence with the old IP code 3rd digit and the corresponding external "Ag" conditions.

The contents of the Protection Classifications charts are for guidance only. If you have any doubt as to the interpretation of the information contained therein, please refer either to the standard itself or contact Legrand.

## Health and Safety at Work, etc. Act. 1974

### Statement to Purchasers and Prospective Purchasers

1. Section 6 of this Act provides that manufacturers, designers, importers or suppliers of articles for use at work have a duty to ensure so far as is reasonably practical, that the article will be safe and without risk to health when properly used. An article is not regarded as being 'properly used' if it is used without regard to any relevant information or advice relating to its use made available by the manufacturer, designer, importer or supplier.

2. With regard to these provisions the following is given as a guide to the information which is readily available to you. This information relates to those products detailed in our catalogue(s) or associated literature or may be obtained by specific request to the Company.

3. All products should be installed and maintained in accordance with good engineering practice and relevant British or

other applicable standards, regulations for the installation of equipment by the Institute of Electrical Engineers or any other applicable Codes of Practice.

### Health and Safety at Work Act

#### The Electricity at Work Regulations, 1989

1. All installations and maintenance should be carried out within the provision of the above Act and by persons so qualified as defined in the Act.

2. Information and advice on the suitability of our products can be obtained from Legrand Electric Limited on specific request.

For information concerning wiring device standards outside the UK contact :

BSI

Customer Services

09:00 to 17:00 – Monday to Friday

Tel : +44 (0) 20 8996 9001

Fax : +44 (0) 20 8996 7001

Email : [cservices@bsi-global.com](mailto:cservices@bsi-global.com)

CE marking appears on electrical or electronic products from Legrand and enables the circulation of goods outside the UK.



**Conditions of sale**  
Please consult our current price list

In accordance with its policy of continuous improvement the Company reserves the right to change specifications and designs without notice. All illustrations, descriptions, dimensions and weights in this catalogue are for guidance and cannot be held binding on the Company.



# LEGRAND WORLDWIDE

- Algeria**  
Legrand  
Tel. : (213) 21 91 38 32  
Fax : (213) 21 91 26 39
- Australia**  
Legrand  
Tel. : (61) 2 87 19 43 33  
Fax : (61) 2 87 19 43 45
- Austria**  
Legrand Osterreich  
Tel. : (43) 1 277 62  
Fax : (43) 1 277 62 225
- Belgium**  
Legrand Belgique S.A.  
Tel. : (32) 2 719 17 11  
Fax : (32) 2 719 17 00
- Belarus**  
Legrand  
Tel. : (375) 17 205 04 78/79  
Fax : (375) 17 205 04 78/79
- Bosnia-Herzegovina**  
Legrand  
Tel. : (387) 33 71 10 25  
Fax : (387) 33 52 17 84
- Brazil**  
GL Electro-Eletronicos Ltda  
Tel. : (55) 11 56 44 26 00  
Fax : (55) 11 51 81 06 04/59 14
- Bulgaria**  
Legrand  
Tel. : (359) 2 489 92 97  
Fax : (359) 2 489 94 70
- Canada**  
Pass & Seymour Canada Inc  
Tel. : (1) 905 738 91 95  
Fax : (1) 905 738 97 21
- Chile**  
Legrand Electro Andina Ltda (EAL)  
Tel. : (56) 2 550 52 00  
Fax : (56) 2 550 53 09
- China**  
Legrand China  
Tel. : (86) 21 52 11 01 11  
Fax : (86) 21 52 11 00 86
- Colombia**  
Legrand Colombia S.A.  
Tel. : (57) 1 437 67 00  
Fax : (57) 1 436 26 54
- Costa Rica**  
Bticino Costa Rica  
Tel. : (506) 22 98 56 00  
Fax : (506) 22 39 04 72
- Croatia**  
Legrand  
Tel. : (385) 1 606 43 50  
Fax : (385) 1 606 43 59
- Cyprus**  
Legrand  
Tel. : (357) 22 318 588  
Fax : (357) 22 318 588
- Czech Republic**  
Legrand s.r.o.  
Tel. : (420) 2 46 00 76 68  
Fax : (420) 2 46 00 76 69
- Egypt**  
EMB Electrical Industries SAE  
Tel. : (202) 23 78 61 50  
Fax : (202) 23 80 70 32
- Estonia**  
Legrand SNC  
Tel. : (372) 67 99 110  
Fax : (372) 67 99 113
- France**  
Legrand S.A.  
Tel. : (33) 5 55 06 87 87  
Fax : (33) 5 55 06 88 88
- Germany**  
Legrand GmbH  
Tel. : (49) 29 21 10 40  
Fax : (49) 29 21 10 42 02
- Greece**  
Helliniki Legrand S.A.  
Tel. : (30) 2 10 67 97 500  
Fax : (30) 2 10 67 97 540
- Hong Kong**  
Legrand (HK) Ltd  
Tel. : (852) 26 87 42 00  
Fax : (852) 26 87 43 00
- Hungary**  
Legrand Zrt  
Tel. : (36) 63 51 02 00  
Fax : (36) 63 51 02 10
- India**  
Legrand (India) Pvt Ltd  
Tel. : (91) 22 30 41 62 00  
Fax : (91) 22 24 93 31 58
- Indonesia**  
PT Legrand Indonesia  
Tel. : (62) 21 525 06 08  
Fax : (62) 21 525 59 35
- Iran**  
Alborz Electrical Industries Ltd  
Tel. : (98) 218 873 94 57/86 70  
Fax : (98) 218 873 79 03
- Italy**  
Bticino S.p.a.  
Tel. : (39) 03 32 27 91 11  
Fax : (39) 03 32 26 56 61
- Jordan**  
Legrand  
Tel. : (962) 64 65 59 02  
Fax : (962) 64 65 59 03
- Kazakhstan**  
Legrand Kazakhstan  
Tel. : (7) 32 72 26 03 63  
Fax : (7) 32 72 26 03 63
- Korea**  
Anam Legrand Co. Ltd  
Tel. : (82) 25 50 32 00  
Fax : (82) 25 50 32 99
- Kuwait**  
Legrand  
Tel. : (965) 22 25 18 20  
Fax : (965) 22 25 18 19
- Lebanon**  
Legrand  
Tel. : (961) 1 422 166  
Fax : (961) 1 422 167
- Lithuania**  
Legrand  
Tel. : (370) 523 56 500  
Fax : (370) 523 56 700
- Malaysia**  
Legrand  
Tel. : (603) 62 04 06 88  
Fax : (603) 62 04 07 88
- Mauritius**  
Legrand  
Tel. : (230) 249 14 00  
Fax : (230) 249 15 00
- Mexico**  
Bticino Mexico S.A. of C.V.  
Tel. : (52) 442 238 04 00  
Fax : (52) 442 238 04 82
- Morocco**  
Simapel  
Tel. : (212) 2 235 93 73  
Fax : (212) 2 235 58 30
- Netherlands**  
Legrand Netherlands B.V.  
Tel. : (31) 411 653 111  
Fax : (31) 411 653 158
- New Caledonia**  
Legrand  
Tel. : (687) 76 49 28  
Fax : (687) 25 95 64
- New Zealand**  
HPM Legrand  
Tel. : (64) 9 442 08 000  
Fax : (64) 9 442 08 003
- Ouzbekistan**  
Legrand  
Tel. : (998) 71 138 9948  
Fax : (998) 71 138 9947
- Peru**  
Bticino del Peru S.A.  
Tel. : (51) 1242 60 00  
Fax : (51) 1242 41 00
- Philippines**  
Bticino Philippines Inc.  
Tel. : (63) 2 89 28 972  
Fax : (63) 2 89 28 971
- Poland**  
Legrand Polska  
Tel. : (48) 748 162 300  
Fax : (48) 748 152 149
- Portugal**  
Legrand Electrica S.A.  
Tel. : (351) 21 454 88 00  
Fax : (351) 21 454 88 86
- Qatar**  
Legrand  
Tel. : (974) 456 90 83  
Fax : (974) 465 99 16
- Reunion**  
Legrand Indian Ocean  
Tel. : 02 62 90 01 80  
Fax : 02 62 90 01 89
- Romania**  
Legrand Romania SRL  
Tel. : (40) 21 232 07 77  
Fax : (40) 21 232 07 76
- Russia**  
Firelec Legrand P.T.  
Tel. : (7) 495 660 75 50/60  
Fax : (7) 495 660 75 51/61
- Saudi Arabia**  
Legrand  
Tel. : (966) 2 651 28 48  
Fax : (966) 2 651 74 34
- Senegal**  
Legrand  
Tel. : (221) 33 865 00 01  
Fax : (221) 33 820 63 69
- Serbia and Montenegro**  
Legrand  
Tel. : (381) 11 26 05 308  
Fax : (381) 11 26 05 267
- Singapore**  
Legrand (S) Pte Ltd  
Tel. : (65) 6416 1550  
Fax : (65) 6416 1580
- Slovakia**  
Legrand  
Tel. : (421) 232 153 601  
Fax : (421) 232 153 609
- Slovenia**  
Legrand SLV d.o.o  
Tel. : 386 (0) 1 562 01 70  
Fax : 386 (0) 1 562 13 12
- South Africa**  
Legrand electrical accessories  
Tel. : (27) 11 444 79 71  
Fax : (27) 11 444 79 80
- Spain**  
Legrand Group España  
Tel. : (34) 91 656 18 12  
Fax : (34) 91 656 67 88
- Switzerland**  
Legrand (Suisse) S.A.  
Tel. : (41) 56 464 67 67  
Fax : (41) 56 464 67 60
- Syria**  
Legrand  
Tel. : (963) 11 33 22 920/970  
Fax : (963) 11 33 22 512
- Thailand**  
Bticino (Thailand) Limited  
Tel. : (66) 2 656 91 62/67  
Fax : (66) 2 656 91 97
- Tunisia**  
Legrand  
Tel. : (216) 71 964 022  
Fax : (216) 71 963 297
- Turkey**  
Legrand Elektrik San. A.S.  
Tel. : (90) 262 648 90 00  
Fax : (90) 262 751 12 67
- U.A.E.**  
Legrand SNC FZE  
Tel. : (971) 48 137 111  
Fax : (971) 48 864 784
- Ukraine**  
Legrand Ukraine Ltd  
Tel. : (38) 044 494 00 10  
Fax : (38) 044 490 67 56
- United States**  
Legrand North America  
Tel. : (1) 860 233 6251  
Fax : (1) 860 570 2813
- Venezuela**  
Bticino De Venezuela C.A.  
Tel. : (58) 212 361 33 33  
Fax : (58) 212 362 25 25
- Vietnam**  
Legrand Vietnam  
Tel. : (848) 9 307 448  
Fax : (848) 9 307 449
- West Indies**  
Legrand  
Tel. : (0) 5 90 86 18 53  
Fax : (0) 5 90 86 23 05
- Other countries :**  
www.legrand.com
- International department direct :**  
Tel. : 33 5 55 06 87 87  
Fax : 33 5 55 06 74 55

## Contact details

### United Kingdom

Great King Street North,  
Birmingham, B19 2LF

### Customer Services:

Tel: +44 (0) 845 605 4333 Fax: +44 (0) 845 605 4334  
E-mail: [legrand.sales@legrand.co.uk](mailto:legrand.sales@legrand.co.uk)

### Quotations and Technical Support:

Tel: +44 (0) 870 608 9020 Fax: +44 (0) 870 608 9021  
E-mail: [uk-wdsales@legrand.co.uk](mailto:uk-wdsales@legrand.co.uk)

### Republic of Ireland:

Tel: 01 295 9673 Fax: 01 295 4671  
E-mail: [legrand.sales@legrand.co.uk](mailto:legrand.sales@legrand.co.uk)



**FOLLOW US AT**

@ [www.legrand.co.uk](http://www.legrand.co.uk)  
[www.legrand.ie](http://www.legrand.ie)

 [www.youtube.com/legrandtvuk](http://www.youtube.com/legrandtvuk)

 [www.voltimum.co.uk](http://www.voltimum.co.uk)  
[www.voltimum.ie](http://www.voltimum.ie)

Distributor:



### Head office (UK and Ireland):

Legrand Electric Limited  
Great King Street North, Birmingham, B19 2LF  
Tel: +44 (0) 870 608 9000 Fax: +44 (0) 870 608 9004  
Website: [www.legrand.co.uk](http://www.legrand.co.uk)

